













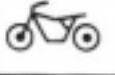







YAMAHA TZ125G1/(G) 1995

① GEN INFO 	② SPEC 	
③ INSP ADJ 	④ ENG 	
⑤ CHAS 	⑥ ELEC 	
⑦ TUN 	⑧ 	
⑨ 	⑩ 	
⑪ 	⑫ 	
⑬ 	⑭ 	
⑮ 	⑯ 	⑰ 
⑱ 	⑲ 	⑳ 

ILLUSTRATED SYMBOLS (Refer to the illustration)

Illustrated symbols ① to ⑦ are designed as thumb tabs to indicate the chapter's number and content.

- ① General information
- ② Specifications
- ③ Regular inspection and adjustment
- ④ Engine
- ⑤ Chassis
- ⑥ Electrical
- ⑦ Tuning







Illustrated symbols ⑧ to ⑭ are used to identify the specifications appearing in the text.

- ⑧ With engine mounted
- ⑨ Special tool
- ⑩ Filling fluid
- ⑪ Lubricant
- ⑫ Tightening
- ⑬ Wear limit, clearance
- ⑭ Resistance (Ω), Voltage (V), Electric current (A)

Illustrated symbols ⑮ to ⑳ in the exploded diagram indicate grade of lubricant and location of lubrication point.

- ⑮ Apply gear oil
- ⑯ Apply engine mixing oil
- ⑰ Apply molybdenum disulfide oil
- ⑱ Apply lightweight lithium-soap base grease
- ⑲ Apply molybdenum disulfide grease
- ⑳ Apply locking agent (LOCTITE®)

INDEX

GENERAL INFORMATION	
	GEN INFO 1
SPECIFICATIONS	
	SPEC 2
REGULAR INSPECTION AND ADJUSTMENTS	
	INSP ADJ 3
ENGINE	
	ENG 4
CHASSIS	
	CHAS 5
ELECTRICAL	
	ELEC 6
TUNING	
	TUN 7

CONTENTS

CHAPTER 1

GENERAL INFORMATION

DESCRIPTION	1-1
MACHINE IDENTIFICATION	1-2
VEHICLE IDENTIFICATION NUMBER (For USA, CDN, AUS, NZ and E)	1-2
FRAME SERIAL NUMBER (Except for USA, CDN, AUS, NZ and E).....	1-2
ENGINE SERIAL NUMBER	1-2
IMPORTANT INFORMATION	1-3
PREPARATION FOR REMOVAL AND DISASSEMBLY.....	1-3
ALL REPLACEMENT PARTS	1-4
GASKETS, OIL SEALS AND O-RINGS.....	1-4
LOCK WASHERS, PLATES AND COTTER PINS	1-4
BEARINGS AND OIL SEALS.....	1-4
CIRCLIPS	1-5
SPECIAL TOOLS	1-5
FOR TUNE UP	1-5
FOR ENGINE SERVICE	1-5
FOR CHASSIS SERVICE.....	1-7
FOR ELECTRICAL SERVICE	1-8
CONTROL FUNCTIONS	1-9
"ENGINE STOP" BUTTON	1-9
CLUTCH LEVER	1-9
SHIFT PEDAL	1-9
THROTTLE GRIP.....	1-9
FRONT BRAKE LEVER	1-9
REAR BRAKE PEDAL	1-10
FUEL COCK	1-10
STARTER KNOB (CHOKE).....	1-10
WATER TEMPERATURE GAUGE	1-10
VALVE JOINT	1-10
MIXING COVER.....	1-11
CARBURETOR COVER	1-11
LOWER COWL	1-11
CATCH TANK	1-11
FLAP.....	1-12
DETACHABLE MAINSTAND	1-12
DETACHABLE SIDESTAND	1-12
FIRE RETARDANT MATERIAL	1-12

FUEL AND ENGINE MIXING OIL	1-13
----------------------------------	------

INFORMATION BEFORE

PRE-OPERATION.....	1-14
PRE-OPERATION CHECK	1-14

PRE-OPERATION CHECK LIST.....	1-16
-------------------------------	------

STARTING AND BREAK-IN.....	1-17
----------------------------	------

STARTING A COLD ENGINE	1-17
------------------------------	------

WARMING UP.....	1-17
-----------------	------

STARTING A WARM ENGINE.....	1-18
-----------------------------	------

BREAK-IN PROCEDURES	1-18
---------------------------	------

TORQUE-CHECK POINTS	1-20
---------------------------	------

CLEANING AND STORAGE.....	1-21
---------------------------	------

CLEANING	1-21
----------------	------

STORAGE.....	1-22
--------------	------

CHAPTER 2

SPECIFICATIONS

SPECIFICATIONS	2-1
----------------------	-----

GENERAL SPECIFICATIONS	2-1
------------------------------	-----

MAINTENANCE SPECIFICATIONS	2-3
----------------------------------	-----

Engine	2-3
--------------	-----

Chassis	2-6
---------------	-----

Electrical	2-10
------------------	------

GENERAL TORQUE

SPECIFICATIONS	2-11
----------------------	------

DEFINITION OF UNITS	2-11
---------------------------	------

CABLE ROUTING DIAGRAM	2-12
-----------------------------	------

SETTING PARTS	2-16
---------------------	------

CARBURETOR.....	2-16
-----------------	------

CYLINDER GASKET.....	2-16
----------------------	------

TRANSMISSION	2-17
--------------------	------

DRIVE, DRIVEN SPROCKET

AND DRIVE CHAIN	2-17
-----------------------	------

CHAPTER 3

REGULAR INSPECTION

AND ADJUSTMENTS

MAINTENANCE INTERVALS	3-1
-----------------------------	-----

LOCKING WIRE INSTALLATION

GUIDE.....	3-4
------------	-----

FUEL AND ENGINE MIXING OIL	1-13
INFORMATION BEFORE	
PRE-OPERATION	1-14
PRE-OPERATION CHECK	1-14
PRE-OPERATION CHECK LIST	1-16
STARTING AND BREAK-IN	
STARTING A COLD ENGINE	1-17
WARMING UP	1-17
STARTING A WARM ENGINE	1-18
BREAK-IN PROCEDURES	1-18
TORQUE-CHECK POINTS	1-20
CLEANING AND STORAGE	
CLEANING	1-21
STORAGE	1-22

CHAPTER 2 SPECIFICATIONS

SPECIFICATIONS	2-1
GENERAL SPECIFICATIONS	2-1
MAINTENANCE SPECIFICATIONS	2-3
Engine	2-3
Chassis	2-6
Electrical	2-10
GENERAL TORQUE SPECIFICATIONS	
	2-11
DEFINITION OF UNITS	
	2-11
CABLE ROUTING DIAGRAM	
	2-12
SETTING PARTS	
CARBURETOR	2-16
CYLINDER GASKET	2-16
TRANSMISSION	2-17
DRIVE, DRIVEN SPROCKET AND DRIVE CHAIN	2-17

CHAPTER 3 REGULAR INSPECTION AND ADJUSTMENTS

MAINTENANCE INTERVALS	3-1
LOCKING WIRE INSTALLATION GUIDE	
	3-4

COOLING WATER LEVEL INSPECTION	3-5
COOLING WATER REPLACEMENT	3-5
RADIATOR CAP INSPECTION	3-7
RADIATOR CAP OPENING PRESSURE INSPECTION	3-7
COOLING SYSTEM INSPECTION	3-8
CLUTCH CARE	3-8
CLUTCH ADJUSTMENT	3-8
PILOT AIR SCREW ADJUSTMENT	3-9
THROTTLE CABLE ADJUSTMENT	3-9
YPVS OPEN SIDE CABLE ADJUSTMENT	3-10
YPVS CLOSE SIDE CABLE ADJUSTMENT	3-11
YPVS COMPONENTS RETIGHTENING	3-11
TRANSMISSION OIL LEVEL CHECK	3-12
TRANSMISSION OIL REPLACEMENT	3-13
BRAKE SYSTEM AIR BLEEDING	3-14
FRONT BRAKE ADJUSTMENT	3-15
REAR BRAKE ADJUSTMENT	3-15
FRONT BRAKE PAD INSPECTION AND REPLACEMENT	3-16
REAR BRAKE PAD INSPECTION AND REPLACEMENT	3-17
BRAKE FLUID LEVEL INSPECTION	3-19
SPROCKETS INSPECTION	3-19
DRIVE CHAIN INSPECTION	3-20
DRIVE CHAIN SLACK ADJUSTMENT	3-22
WHEEL ALIGNMENT ADJUSTMENT	3-23
FRONT FORK INSPECTION	3-25
FRONT FORK TOP END ADJUSTMENT	3-25
FRONT FORK SPRING PRELOAD ADJUSTMENT	3-27
FRONT FORK REBOUND DAMPING FORCE ADJUSTMENT	3-27
FRONT FORK COMPRESSION DAMPING FORCE ADJUSTMENT	3-28
REAR SHOCK ABSORBER INSPECTION	3-29
SEAT HEIGHT ADJUSTMENT	3-30
REAR SHOCK ABSORBER SPRING PRELOAD ADJUSTMENT	3-30
REAR SHOCK ABSORBER REBOUND DAMPING FORCE ADJUSTMENT	3-31

COOLING WATER LEVEL INSPECTION	3-5
COOLING WATER REPLACEMENT ...	3-5
RADIATOR CAP INSPECTION	3-7
RADIATOR CAP OPENING PRESSURE INSPECTION	3-7
COOLING SYSTEM INSPECTION	3-8
CLUTCH CARE	3-8
CLUTCH ADJUSTMENT	3-8
PILOT AIR SCREW ADJUSTMENT ...	3-9
THROTTLE CABLE ADJUSTMENT ...	3-9
YPVS OPEN SIDE CABLE ADJUSTMENT	3-10
YPVS CLOSE SIDE CABLE ADJUSTMENT	3-11
YPVS COMPONENTS RETIGHTENING	3-11
TRANSMISSION OIL LEVEL CHECK	3-12
TRANSMISSION OIL REPLACEMENT	3-13
BRAKE SYSTEM AIR BLEEDING ...	3-14
FRONT BRAKE ADJUSTMENT	3-15
REAR BRAKE ADJUSTMENT	3-15
FRONT BRAKE PAD INSPECTION AND REPLACEMENT	3-16
REAR BRAKE PAD INSPECTION AND REPLACEMENT	3-17
BRAKE FLUID LEVEL INSPECTION ...	3-19
SPROCKETS INSPECTION	3-19
DRIVE CHAIN INSPECTION	3-20
DRIVE CHAIN SLACK ADJUSTMENT	3-22
WHEEL ALIGNMENT ADJUSTMENT ..	3-23
FRONT FORK INSPECTION	3-25
FRONT FORK TOP END ADJUSTMENT	3-25
FRONT FORK SPRING PRELOAD ADJUSTMENT	3-27
FRONT FORK REBOUND DAMPING FORCE ADJUSTMENT	3-27
FRONT FORK COMPRESSION DAMPING FORCE ADJUSTMENT ...	3-28
REAR SHOCK ABSORBER INSPECTION	3-29
SEAT HEIGHT ADJUSTMENT	3-30
REAR SHOCK ABSORBER SPRING PRELOAD ADJUSTMENT	3-30
REAR SHOCK ABSORBER REBOUND DAMPING FORCE ADJUSTMENT ...	3-31

REAR SHOCK ABSORBER COMPRESSION DAMPING FORCE ADJUSTMENT	3-32
TIRE PRESSURE CHECK	3-33
TIRE INSPECTION	3-33
WHEEL INSPECTION	3-34
STEERING HEAD INSPECTION AND ADJUSTMENT	3-34
STEERING DAMPER ADJUSTMENT	3-36
WIRES, CABLES	3-36
MUFFLER INSPECTION	3-36
SILENCER INSPECTION	3-37
COWLING INSTALLATION INSPECTION	3-37
LUBRICATION	3-38
SPARK PLUG INSPECTION	3-39
IGNITION TIMING CHECK	3-40

CHAPTER 4 ENGINE

COWLING, SEAT, FUEL TANK, EXHAUST PIPE AND SILENCER	4-1
PREPARATION FOR REMOVAL	4-1
RADIATOR	4-3
PREPARATION FOR REMOVAL	4-3
NOTE ON REMOVAL AND REASSEMBLY	4-4
REMOVAL POINTS	4-4
Radiator	4-4
INSPECTION	4-5
Radiator	4-5
ASSEMBLY AND INSTALLATION ...	4-5
Radiator	4-5
CARBURETOR AND REED VALVE	4-7
PREPARATION FOR REMOVAL	4-7
NOTE ON REMOVAL AND REASSEMBLY	4-8
REMOVAL POINTS	4-9
Throttle valve	4-9
Float chamber	4-9
INSPECTION	4-9
Carburetor	4-9
Needle valve	4-10
Throttle valve	4-10
Float arm height	4-11
Float	4-11
Reed valve	4-11

ASSEMBLY AND INSTALLATION	4-12
Reed valve	4-12
Carburetor	4-13
Carburetor installation	4-15
CYLINDER HEAD, CYLINDER AND PISTON	4-17
PREPARATION FOR REMOVAL	4-17
NOTE ON REMOVAL AND REASSEMBLY	4-18
REMOVAL POINTS	4-18
YPVS cable	4-18
Piston and piston ring	4-19
Power valve	4-20
INSPECTION	4-20
Cylinder head	4-20
Cylinder	4-21
Piston	4-22
Piston pin and small end bearing	4-22
Piston ring	4-23
Piston clearance	4-24
Combination of piston and cylinder	4-24
Power valve	4-25
Power valve hole on cylinder	4-25
ASSEMBLY AND INSTALLATION	4-26
Power valve	4-26
Piston ring and piston	4-27
Cylinder head and cylinder	4-28
CLUTCH	4-31
PREPARATION FOR REMOVAL	4-31
NOTE ON REMOVAL AND REASSEMBLY	4-32
REMOVAL POINTS	4-32
Clutch boss	4-32
INSPECTION	4-33
Clutch housing and boss	4-33
Clutch housing	4-33
Clutch spring	4-33
Friction plate	4-33
Clutch plate	4-34
Push lever axle	4-34
Push rod axle	4-34
ASSEMBLY AND INSTALLATION	4-34
Push lever axle	4-34
Clutch	4-35
PRIMARY DRIVE GEAR, PRIMARY DRIVEN GEAR AND BALANCER SHAFT	4-39
PREPARATION FOR REMOVAL	4-39
NOTE ON REMOVAL AND REASSEMBLY	4-40

REMOVAL POINTS	4-40
Primary drive gear and balancer weight gear	4-40
Balancer shaft	4-41
INSPECTION	4-41
Primary drive gear and primary driven gear	4-41
Balancer weight gear and balancer drive gear	4-41
Crankcase cover (right)	4-42
Balancer shaft	4-42
ASSEMBLY AND INSTALLATION	4-42
Balancer shaft and primary drive gear	4-42
Primary driven gear	4-45

SHIFT SHAFT AND OIL PUMP	4-47
PREPARATION FOR REMOVAL	4-47
NOTE ON REMOVAL AND REASSEMBLY	4-48
INSPECTION	4-48
Shift shaft	4-48
Stopper lever	4-48
Oil pump	4-49
Strainer	4-49
ASSEMBLY AND INSTALLATION	4-49
Strainer	4-49
Oil pump	4-50
Stopper lever	4-51
Shift shaft	4-52

TRANSMISSION, SHIFT CAM AND SHIFT FORK	4-53
PREPARATION FOR REMOVAL	4-53
NOTE ON REMOVAL AND REASSEMBLY	4-54
REMOVAL POINTS	4-54
Drive sprocket	4-54
Transmission housing	4-55
Transmission	4-55
Shift cam	4-55
INSPECTION	4-55
Oil delivery pipe	4-55
Gears	4-56
Shift fork groove	4-56
Bearing	4-56
Shift fork and shift cam	4-57
ASSEMBLY AND INSTALLATION	4-57
Shift cam	4-57
Drive sprocket	4-61

CDI MAGNETO	4-63
PREPARATION FOR REMOVAL	4-63
NOTE ON REMOVAL AND REASSEMBLY	4-64
REMOVAL POINTS.....	4-64
Rotor	4-64
INSPECTION	4-64
CDI magneto	4-64
Woodruff key	4-65
ASSEMBLY AND INSTALLATION	4-65
CDI magneto	4-65

ENGINE REMOVAL	4-69
PREPARATION FOR REMOVAL	4-69
NOTE ON REMOVAL AND REASSEMBLY	4-70
REMOVAL POINTS.....	4-70
Engine removal.....	4-70
ASSEMBLY AND INSTALLATION	4-71
Engine installation	4-71

CRANKCASE, CRANKSHAFT AND WATER PUMP	4-73
PREPARATION FOR REMOVAL.....	4-73
NOTE ON REMOVAL AND REASSEMBLY	4-74
REMOVAL POINTS	4-74
Crankcase	4-74
Crankshaft.....	4-75
Impeller shaft	4-76
Oil seal	4-76
INSPECTION	4-76
Crankcase	4-76
Crankshaft.....	4-77
Impeller shaft	4-77
Oil seal.....	4-77
ASSEMBLY AND INSTALLATION	4-78
Oil seal (impeller shaft).....	4-78
Impeller shaft	4-78
Oil seal (crankshaft)	4-79
Crankshaft.....	4-79

CHAPTER 5 CHASSIS

FRONT WHEEL	5-1
PREPARATION FOR REMOVAL.....	5-1
REMOVAL POINTS	5-2
Wheel bearing (if necessary).....	5-2
INSPECTION	5-2
Front wheel.....	5-2
Front wheel axle.....	5-2
Brake disc	5-3
ASSEMBLY AND INSTALLATION	5-3
Front wheel.....	5-3

REAR WHEEL	5-7
PREPARATION FOR REMOVAL.....	5-7
REMOVAL POINTS	5-8
Rear wheel	5-8
Wheel bearing (if necessary).....	5-8
INSPECTION	5-8
Rear wheel	5-8
Rear wheel axle.....	5-9
Brake disc	5-9
Clutch hub.....	5-10
ASSEMBLY AND INSTALLATION	5-10
Rear wheel	5-10

FRONT BRAKE	5-15
PREPARATION FOR REMOVAL.....	5-15
REMOVAL POINTS	5-17
Caliper	5-17
Caliper piston	5-17
Piston seal kit	5-18
Master cylinder kit	5-18
INSPECTION	5-18
Master cylinder.....	5-18
Caliper	5-19
Brake hose.....	5-19
ASSEMBLY AND INSTALLATION	5-19
Caliper piston	5-20
Caliper	5-20
Master cylinder kit	5-21
Master cylinder.....	5-22
Brake hose.....	5-23
Brake fluid.....	5-24

REAR BRAKE	5-27
PREPARATION FOR REMOVAL.....	5-27
REMOVAL POINTS	5-29
Caliper	5-29
Caliper piston.....	5-29
Piston seal kit	5-29
Master cylinder kit	5-30
INSPECTION	5-30
Master cylinder.....	5-30
Caliper	5-31
Brake hose.....	5-31
ASSEMBLY AND INSTALLATION	5-31
Caliper piston	5-31
Caliper	5-32
Master cylinder kit	5-33
Master cylinder.....	5-34
Brake hose.....	5-34
Brake fluid.....	5-35

FRONT FORK	5-37
PREPARATION FOR REMOVAL.....	5-37
HANDLING NOTE	5-38
REMOVAL POINTS	5-39
Cap bolt.....	5-39
Oil seal.....	5-39

Damper rod	5-40
INSPECTION	5-40
Damper rod	5-40
Fork spring	5-40
Inner tube	5-41
Outer tube	5-41
Cap bolt	5-41
ASSEMBLY AND INSTALLATION	5-42
Front fork assembly	5-42
Installation	5-48
STEERING	5-51
PREPARATION FOR REMOVAL	5-51
REMOVAL POINTS	5-52
Ring nut	5-52
INSPECTION	5-52
Bearing	5-52
Steering shaft	5-53
Steering damper	5-53
ASSEMBLY AND INSTALLATION	5-53
Under bracket	5-53
SWINGARM	5-59
PREPARATION FOR REMOVAL	5-59
NOTE ON REMOVAL AND REASSEMBLY	5-60
REMOVAL POINTS	5-60
Swingarm	5-60
INSPECTION	5-61
Swingarm	5-61
Relay arm	5-61
Connecting rod	5-61
Swingarm side clearance	5-62
ASSEMBLY AND INSTALLATION	5-63
Swingarm	5-63
REAR SHOCK ABSORBER	5-65
PREPARATION FOR REMOVAL	5-65
HANDLING NOTE	5-66
NOTES ON DISPOSAL (YAMAHA DEALERS ONLY)	5-67
REMOVAL POINTS	5-67
Rear shock absorber	5-67
Spring (rear shock absorber)	5-68
INSPECTION	5-68
Rear shock absorber	5-68
ASSEMBLY AND INSTALLATION	5-69
Spring (rear shock absorber)	5-69
Rear shock absorber	5-69

CHAPTER 6 ELECTRICAL

ELECTRICAL COMPONENTS AND WIRING DIAGRAM	6-1
ELECTRICAL COMPONENTS	6-1
WIRING DIAGRAM	6-1
IGNITION SYSTEM	6-2
INSPECTION STEPS	6-2
SPARK GAP TEST	6-3
SPARK PLUG CAP INSPECTION	6-3
COUPLERS AND LEADS	
CONNECTION INSPECTION	6-3
"ENGINE STOP" BUTTON	
INSPECTION	6-4
IGNITION COIL INSPECTION	6-4
CDI MAGNETO INSPECTION	6-5
CDI UNIT INSPECTION	6-5
YPVS SYSTEM	6-6
INSPECTION STEPS	6-6
COUPLERS AND LEADS	
CONNECTION INSPECTION	6-7
SERVOMOTOR OPERATION	6-7
SERVOMOTOR INSPECTION	6-7
OUT-PUT VOLTAGE INSPECTION	6-8
SOLENOID VALVE SYSTEM	6-9
INSPECTION STEPS	6-9
COUPLERS AND LEADS	
CONNECTION INSPECTION	6-10
SOLENOID VALVE OPERATION	6-10
SOLENOID VALVE INSPECTION	6-10

CHAPTER 7 TUNING

Carburetor setting	7-1
Atmospheric conditions and carburetor setting	7-2
Effects of setting parts in relation to throttle valve opening	7-2
Basic process of carburetor setting	7-3
Carburetor settings by correction coefficient	7-5
Table of correction coefficients for carburetor setting	7-6

Other setting parts.....	7-7
Plug chop.....	7-8
Setting of cylinder gasket	7-8
Measuring piston protrusion	7-10
Selection of transmisson gear ratio	7-11
Suspension setting	7-12
Settings.....	7-13
Symptom.....	7-15
Setting record table.....	7-17



ALL REPLACEMENT PARTS

1. We recommend to use Yamaha genuine parts for all replacements. Use oil and/or grease recommended by Yamaha for assembly and adjustment.

GASKETS, OIL SEALS AND O-RINGS

1. All gaskets, oil seals, and O-rings should be replaced when an engine is overhauled. All gasket surfaces, oil seal lips, and O-rings must be cleaned.
2. Properly oil all mating parts and bearings during reassembly. Apply grease to the oil seal lips.

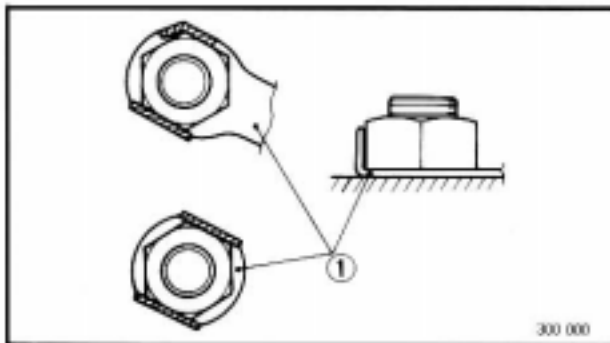

300-000

LOCK WASHERS, PLATES AND COTTER PINS

1. All lock washers/plates (1) and cotter pins must be replaced when they are removed. Lock tab(s) should be bent along the bolt or nut flat(s) after the bolt or nut has been properly tightened.

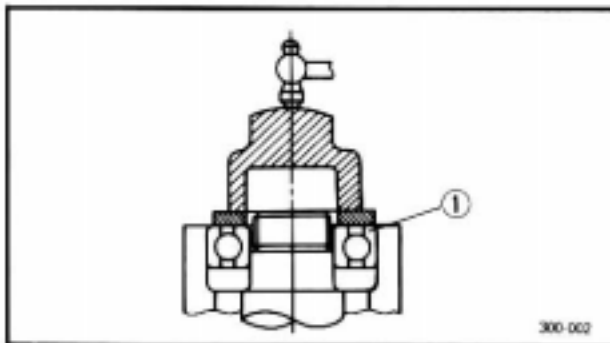

300-002

BEARINGS AND OIL SEALS

1. Install the bearing(s) (1) and oil seal(s) (2) with their manufacturer's marks or numbers facing outward. (In other words, the stamped letters must be on the side exposed to view.) When installing oil seal(s), apply a light coating of light-weight lithium base grease to the seal lip(s). Oil the bearings liberally when installing.

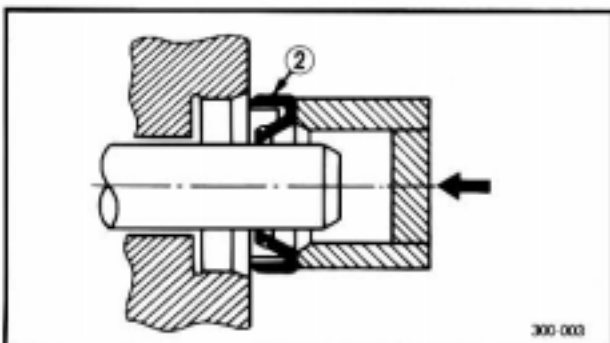

300-003

CAUTION:

Do not use compressed air to spin the bearings dry. This causes damage to the bearing surfaces.

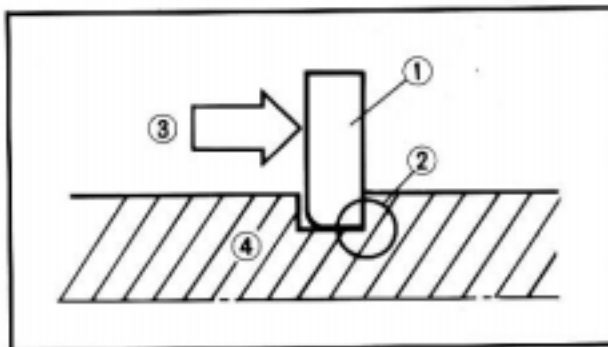

1

**CIRCLIPS**

1. All circlips should be inspected carefully before reassembly. Always replace piston pin clips after one use. Replace distorted circlips. When installing a circlip (1), make sure that the sharp-edged corner (2) is positioned opposite to the thrust (3) it receives. See the sectional view.

(4) Shaft

SPECIAL TOOLS

The following special tools are required to perform maintenance, adjustments, and repairs on your machine. These tools can be obtained through your Yamaha dealer.

NOTE:

- For U.S.A. and Canada, use part number starting with "YM-" or "YU-".
- For others, use part number starting with "90890-".

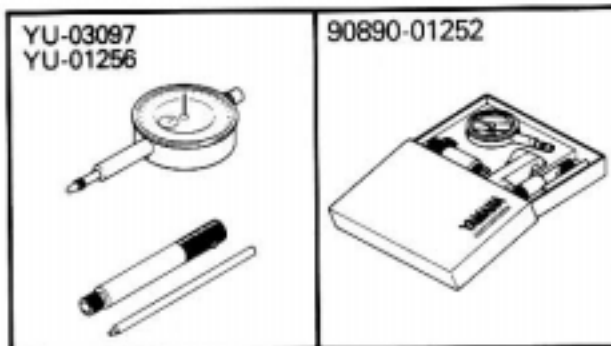
**FOR TUNE UP**

1. Dial gauge and stand
P/N. YU-03097, YU-01256
90890-01252

These tools are used to set the ignition timing.

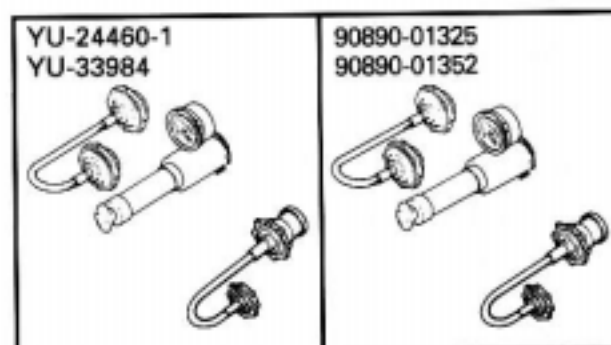
**FOR ENGINE SERVICE**

1. Radiator cap tester and adapter
Radiator cap tester P/N. YU-24460-1
90890-01325
Adapter P/N. YU-33984
90890-01352

These tools are used for checking the cooling system.



1

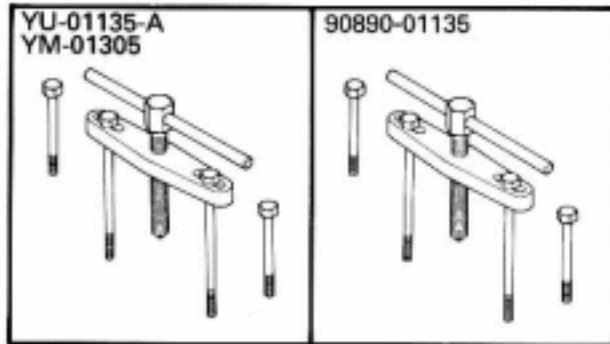

2. Crankcase separating tool
P/N. YU-01135-A, YM-01305
90890-01135, 90890-01305

This tool is used to split the crankcases as well as remove the crankshaft from either case.

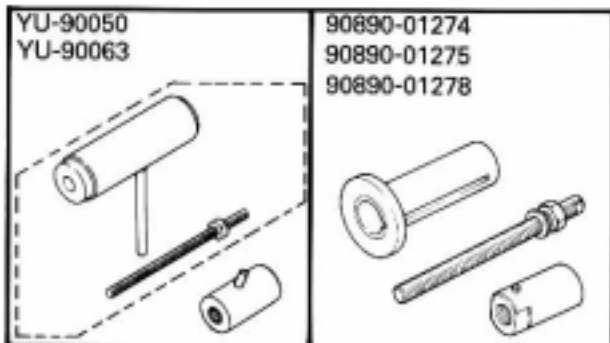

3. Crankshaft installing tool
Pot P/N. YU-90050, 90890-01274
Bolt P/N. YU-90050, 90890-01275
Adapter P/N. YU-90063, 90890-01278

These tools are used to install the crankshaft.

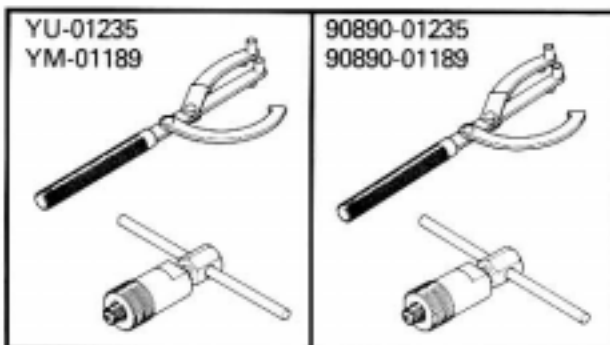

4. Rotor holder and rotor puller
Holder P/N. YU-01235
90890-01235

This tool is used when loosening or tightening the flywheel magneto securing nut.

- Puller P/N. YM-01189
90890-01189

This tool is used to remove the magneto.

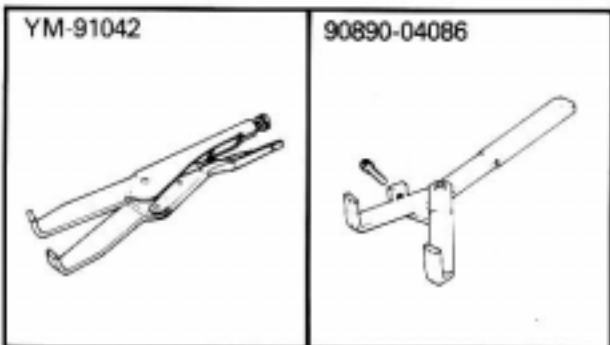

5. Clutch holder
P/N. YM-91042
90890-04086

This tool is used to hold the clutch when removing or installing the clutch boss securing nut.

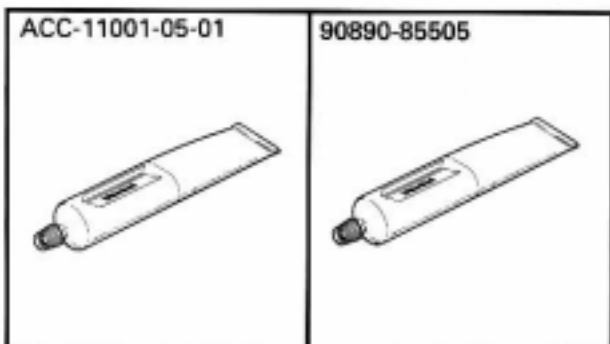

6. Quick gasket*
P/N. ACC-11001-05-01
YAMAHA Bond No. 1215
P/N. 90890-85505

This sealant (Bond) is used for crankcase mating surfaces, etc.



1

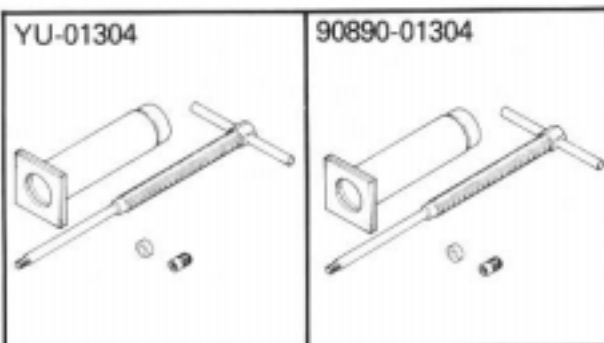

YU-01304

90890-01304

7. Piston pin puller
P/N. YU-01304
90890-01304

This tool is used to pull up the piston pin.

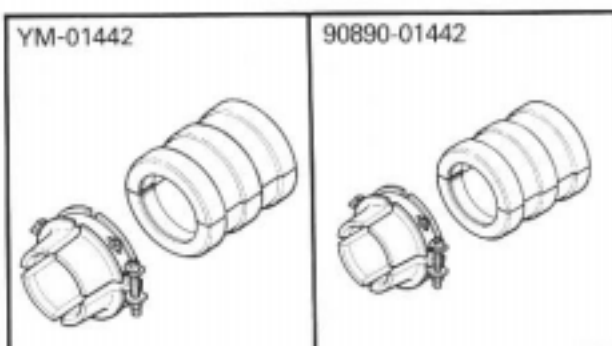

YM-01442

90890-01442

FOR CHASSIS SERVICE

1. Fork seal driver
P/N. YM-01442
90890-01442

This tool is used when install the fork oil seal.

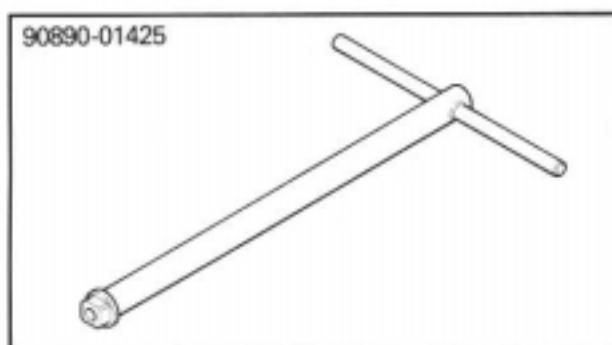

90890-01425

2. Damper rod holder
P/N. 90890-01425

Use this tool to remove and install the damper rod.

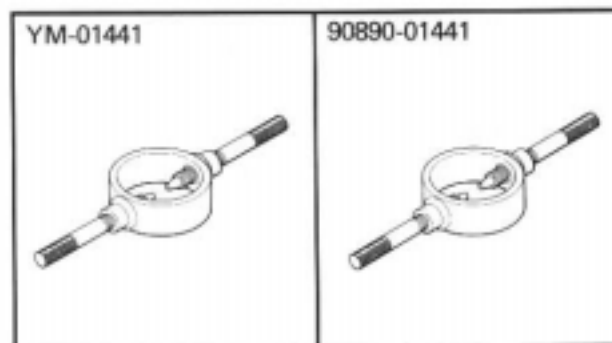

YM-01441

90890-01441

3. Fork spring compressor
P/N. YM-01441
90890-01441

This tool is used to compress the fork spring.

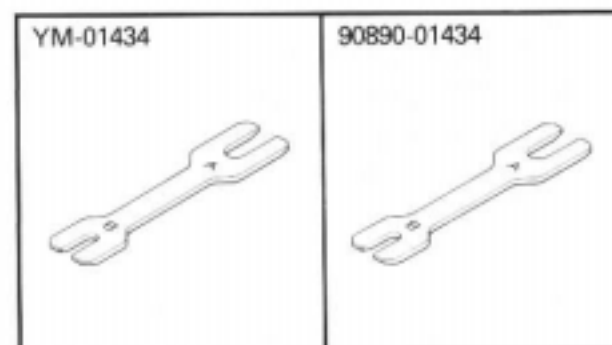

YM-01434

90890-01434

4. Rod holder
P/N. YM-01434
90890-01434

This tool is used to hold the fork spring.



1

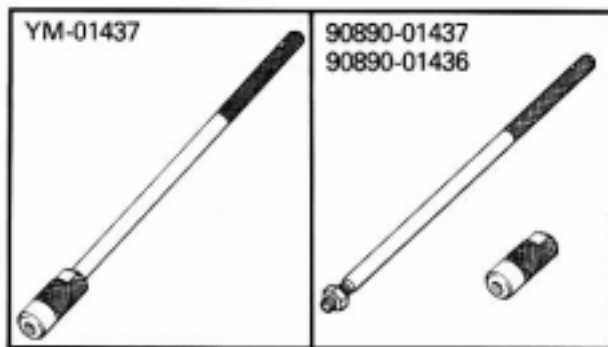

5. Rod puller and rod puller attachment
 Rod puller P/N. YM-01437
 90890-01437
 Rod puller attachment P/N. 90890-01436
 These tools are used to pull up the fork damper rod.

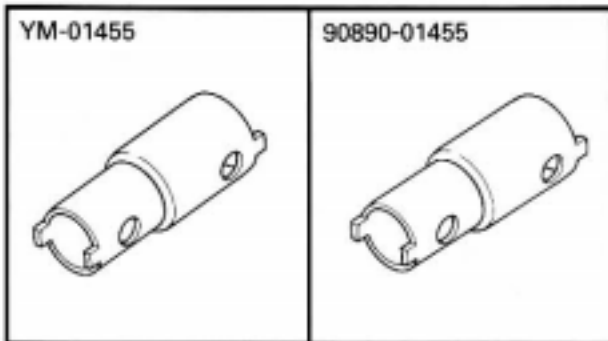

6. Pivot shaft wrench
 P/N. YM-01455
 90890-01455

This tool is used to loosen or tighten the pivot adjust bolt.

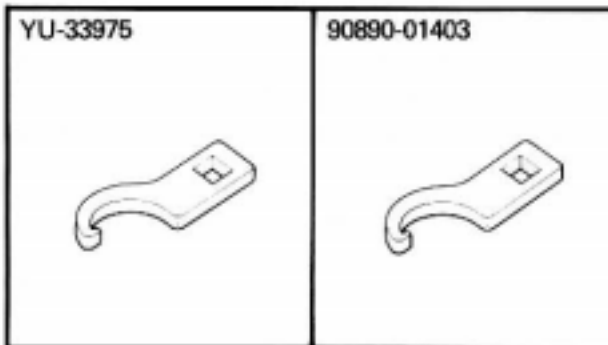

7. Ring nut wrench
 P/N. YU-33975
 90890-01403

This tool is used when tighten the steering ring nut to specification.

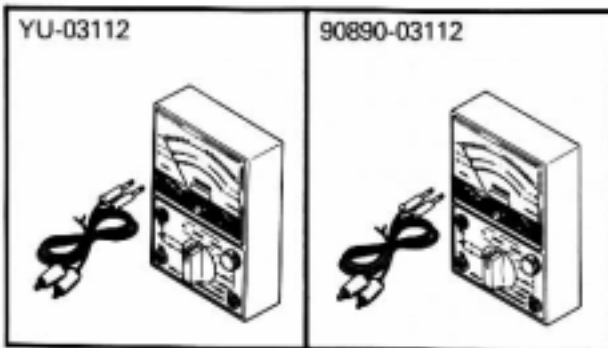

FOR ELECTRICAL SERVICE

1. Yamaha pocket tester
 P/N. YU-03112
 90890-03112

Use this tool to inspect the coil resistance, output voltage and amperage.

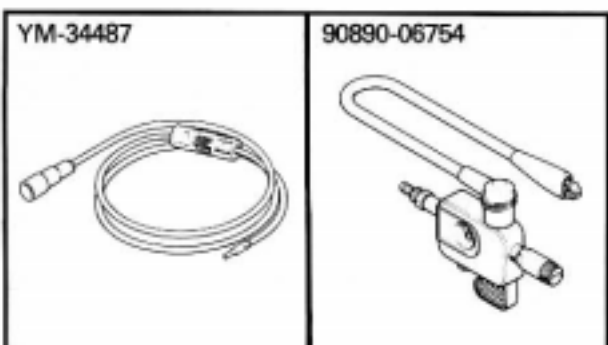

2. Dynamic spark tester
 P/N. YM-34487
 Ignition checker
 P/N. 90890-06754

This instrument is necessary for checking the ignition system components.



FUEL AND ENGINE MIXING OIL

Mix oil with the gas at the ratio specified below. Always use fresh, name-brand gasoline, and mix the oil and gas the day of the race. Do not use premix that is more than a few hours old.

1



Recommended fuel:

Premium leaded gasoline with a research octane number of 100 or higher.

CAUTION:

Never mix two types of oil in the same batch; clotting of the oil could result. If you wish to change oil types, be sure to drain the fuel tank and the carburetor float bowl of old premix prior to filling with the new type.

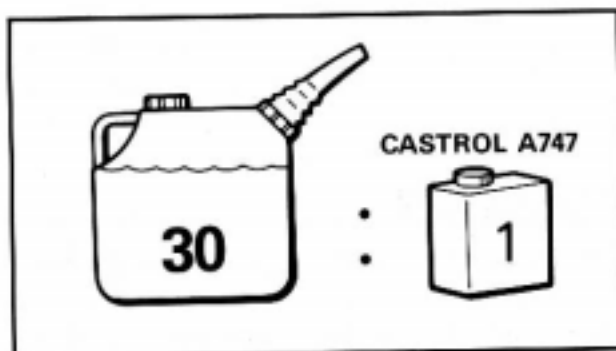

Fuel tank capacity:

13.0 L
(2.60 Imp gal, 3.43 US gal)



Mixing oil

Recommended oil:
Castrol A747
Mixing ratio: 30 : 1

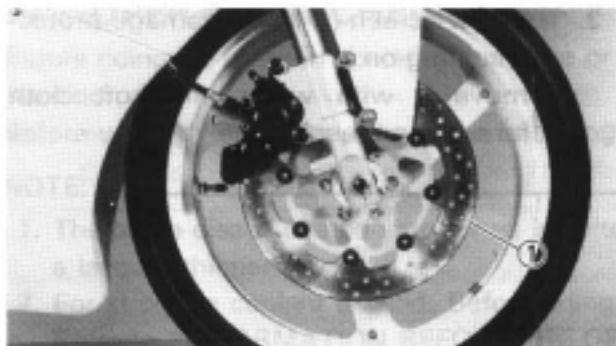

**INFORMATION BEFORE
PRE-OPERATION**

PRE-OPERATION CHECK

1. The brake disc ① is coated with a rust-inhibiter.

Before riding the machine, thoroughly remove it using a lacquer thinner.

⚠ WARNING

- **LACQUER THINNER IS HIGHLY FLAMMABLE.**

Always turn off the engine while using lacquer thinner. Take care not to spill any lacquer thinner on the engine or exhaust system.

Never use it in the vicinity of an open flame, or while smoking.

- **LACQUER THINNER CAN CAUSE INJURY.**

Always use lacquer thinner in a well ventilated area. If you should swallow some lacquer thinner, inhale excess lacquer thinner vapors, or allow any lacquer thinner to get into your eyes, contact a doctor immediately.

NOTE:

- When the machine is not in use for a long time, apply a rust-inhibiter to the brake disc.
- After riding in the rainy weather, wipe the moisture completely off the disc.
- If rust appears on the brake disc, carefully remove it using #400 sand paper.

1



2. The cooling system is filled with coolant at the factory to prevent rusting. Be sure to replace coolant with soft water before riding.

CAUTION:

Hard water or salt water is harmful to the engine parts. You may use distilled water, if you can't get soft water.



SPECIFICATIONS

GENERAL SPECIFICATIONS

Model	TZ125
Model name:	TZ125G1 (USA) TZ125(G) (OTHERS)
Model code number:	4JT2
Frame starting number:	4JT-004101 (OTHERS)
Vehicle identification number:	JYA4JTW0*SA004101 (USA, CDN, AUS, NZ, E)
Engine starting number:	4JT-004101
Dimensions:	
Overall length	1,800 mm (70.9 in)
Overall width	510 mm (20.1 in)
Overall height	1,010 mm (39.8 in)
Seat height	710 mm (28.0 in)
Wheelbase	1,220 mm (40.0 in)
Minimum ground clearance	110 mm (4.3 in)
Basic weight:	
With oil and full fuel tank	81 kg (179 lb)
Engine:	
Engine type	Liquid cooled 2-stroke, gasoline
Cylinder arrangement	Single cylinder, forward inclined
Displacement	124 cm ³ (4.36 Imp oz, 4.19 US oz)
Bore × Stroke	56.0 × 50.7 mm (2.205 × 1.996 in)
Compression ratio	8.3 : 1
Starting system	Push to start
Lubrication system:	Premix (30 : 1) (Castrol A747)
Oil type or grade (2-Cycle):	
Transmission oil	Castrol R30
Periodic oil change	0.30 L (0.26 Imp qt, 0.32 US qt)
Total amount	0.33 L (0.29 Imp qt, 0.35 US qt)
Cooling water capacity (including all routes):	0.89 L (0.78 Imp qt, 0.94 US qt)
Fuel:	
Type	Premium leaded gasoline with a research octane number of 100 or higher
Tank capacity	13.0 L (2.86 Imp gal, 3.43 US gal)
Carburetor:	
Type/Manufacturer	TM38SS/MIKUNI

2



Model	TZ125
Spark plug: Type/Manufacturer Gap	R6385-105P/NGK 0.5--0.6 mm (0.020--0.024 in)
Clutch type:	Dry, multiple-disc
Transmission: Primary reduction system Primary reduction ratio Secondary reduction system Secondary reduction ratio Transmission type Operation Gear ratio: 1st 2nd 3rd 4th 5th 6th	Spur gear 60/21 (2.857) Chain drive 36/17 (2.118) Constant mesh, 6-speed Left foot operation 30/15 (2.000) 27/17 (1.588) 26/19 (1.368) 27/22 (1.227) 26/23 (1.130) 29/27 (1.074)
Chassis: Frame type Caster angle Trail	Delta box 22.2° 81 mm (3.19 in)
Tire: Type Size (F) Size (R) Tire pressure (front and rear)	Tubeless 2.65/3.25-17 115/65-R17 190 kPa (1.9 kg/cm ² , 27 psi)
Brake: Front brake type Operation Rear brake type Operation	Single disc brake Right hand operation Single disc brake Right foot operation
Suspension: Front suspension Rear suspension	Telescopic fork Swingarm (link type monocross suspension)
Shock absorber: Front shock absorber Rear shock absorber	Coil spring/oil damper Coil spring/gas, oil damper
Wheel travel: Front wheel travel Rear wheel travel	104 mm (4.09 in) 109 mm (4.29 in)
Electrical: Ignition system	CDI Magneto

2



MAINTENANCE SPECIFICATIONS

ENGINE

2

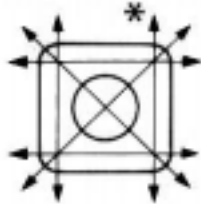
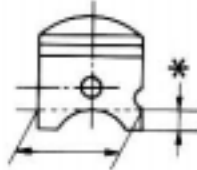
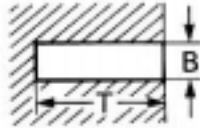
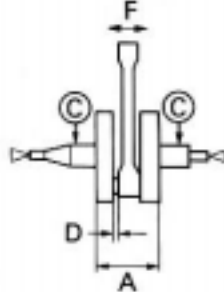
Model	TZ125
Cylinder head: Warp limit 	<0.03 mm (0.0012 in)> *Lines indicate straightedge measurement.
Cylinder: Bore size Wear limit Taper limit Out of round limit	56.000 ~ 56.020 mm (2.2047 ~ 2.2055 in) 56.1 mm (2.209 in) <0.05 mm (0.0020 in)> <0.01 mm (0.0004 in)>
Piston: Piston size/ Measuring point* Piston clearance <Limit> Piston offset 	55.950 ~ 55.970 mm (2.2028 ~ 2.2035 in) / 19 mm (0.75 in) 0.045 ~ 0.055 mm (0.0018 ~ 0.0022 in) <0.1 mm (0.004 in)> 1.0 mm (0.039 in), EX-side
Piston pin: Piston pin outside diameter/ <Limit>	15.995 ~ 16.000 mm (0.6297 ~ 0.6299 in) / <15.975 mm (0.6289 in)>
Piston ring: Sectional sketch  End gap (installed)/ <Limit> Side clearance (installed)/ <Limit>	Plain B = 1.0 mm (0.039 in) T = 2.2 mm (0.087 in) 0.20 ~ 0.35 mm (0.008 ~ 0.014 in) / <0.55 mm (0.022 in)> 0.03 ~ 0.07 mm (0.0012 ~ 0.0028 in) / <0.1 mm (0.0039 in)>
Crankshaft: Crank width "A" Runout limit "C" Connecting rod big end side clearance "D" Small end free play "F" 	52.90 ~ 52.95 mm (2.083 ~ 2.085 in) <0.03 mm (0.0012 in)> 0.2 ~ 0.7 mm (0.008 ~ 0.028 in) 0.8 ~ 1.0 mm (0.031 ~ 0.039 in)
Clutch: Friction plate thickness/Quantity <Wear limit> Clutch plate thickness/Quantity <Warp limit>	2.9 ~ 3.1 mm (0.114 ~ 0.122 in) × 6 <2.7 mm (0.106 in)> 1.4 ~ 1.8 mm (0.055 ~ 0.071 in) × 5 <0.1 mm (0.004 in)>

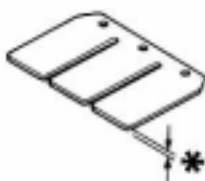

Model	TZ125
Clutch spring free length/Quantity <Limit> Clutch housing thrust clearance Clutch housing radial clearance Clutch release method	36.0 mm (1.417 in) × 5 <35.0 mm (1.378 in)> 0.07~0.18 mm (0.003~0.007 in) 0.009~0.071 mm (0.0004~0.0028 in) Inner push, cam push
Transmission: Main axle deflection limit Drive axle deflection limit	 <0.01 mm (0.0004 in)> <0.01 mm (0.0004 in)>
Shifter: Shifting type Guide bar bending limit	Cam drum and guide bar <0.04 mm (0.0016 in)>
Carburetor: Type/Manufacturer I.D. Mark Main jet (M.J.) Jet needle-clip position (J.N.) Main nozzle (N.J.) Cutaway (C.A.) Pilot jet (P.J.) Pilot air screw (P.A.S.) Valve seat size (V.S.) Starter jet (G.S.) Power jet (P.W.J.) Float level height (F.H.)	TM38SS/MIKUNI 4JT10 #560 6DFI2-61-3 R-7 3.5 #20 1-1/2 φ3.5 1.0 #60 15.2~17.2 mm (0.60~0.68 in)
Reed valve: Thickness* reed valve 1 reed valve 2 Valve stopper height Valve bending limit	 0.42 mm (0.017 in) 0.34 mm (0.013 in) 10.6~11.0 mm (0.417~0.433 in) 0.2 mm (0.008 in)
Cooling: Radiator core size: Width Height Thickness Radiator cap opening pressure Radiator capacity Water pump: Type	 300 mm (11.81 in) 197.8 mm (7.79 in) 32 mm (1.26 in) 95~125 kPa (0.95~1.25 kg/cm ² , 13.5~17.8 psi) 0.55 L (0.48 Imp qt, 0.58 US pt) Single-suction centrifugal pump

2



Parts to be tightened	Thread size	Q'ty	Tightening torque		
			Nm	m•kg	ft•lb
Spark plug	M14S × 1.25	1	19	1.9	1.3
Cylinder head (bolt)	M 6 × 1.0	6	11	1.1	8.0
Cylinder (nut)	M 8 × 1.25	4	20	2.0	14
Cylinder (stud)	M 8 × 1.25	4	15	1.5	11
Power valve cover	M 5 × 0.8	4	4	0.4	2.9
holder 1	M 5 × 0.8	1	4	0.4	2.9
pulley	M 5 × 0.8	1	4	0.4	2.9
cable stay	M 5 × 0.8	2	7	0.7	5.1
Air bleed bolt (cylinder)	M 6 × 1.0	1	12	1.2	8.7
Balance weight gear	M14 × 1.0	1	50	5.0	36
Water pump housing cover	M 6 × 1.0	3	11	1.1	8.0
Radiator	M 6 × 1.0	3	7	0.7	5.1
Radiator and thermo sensor	M16 × 1.5	1	7	0.7	5.1
Radiator hose clamp	—	6	2	0.2	1.4
Oil pump cover	M 5 × 0.8	1	4	0.4	2.9
Oil pump assembly	M 6 × 1.0	2	7	0.7	5.1
Carburetor joint	M 6 × 1.0	6	11	1.1	8.0
Clamp (carburetor joint)	M 4 × 0.7	1	2	0.2	1.4
Reed valve	M 3 × 0.5	6	1	0.1	0.7
Exhaust pipe	M 8 × 1.25	1	21	2.1	15
Silencer	M 6 × 1.0	2	11	1.1	8.0
Crankcase	M 6 × 1.0	13	11	1.1	8.0
Transmission housing	M 6 × 1.0	7	14	1.4	10
Holder (crankshaft oil seal)	M 8 × 1.25	1	16	1.6	11
Blind plug	M 8 × 1.25	1	11	1.1	8.0
Oil drain bolt	M12 × 1.5	1	23	2.3	17
Oil check bolt	M 6 × 1.0	1	9	0.9	6.5
Crankcase cover (left)	M 6 × 1.0	3	11	1.1	8.0
Crankcase cover (right)	M 6 × 1.0	10	11	1.1	8.0
Primary drive gear	M10 × 1.25	1	55	5.5	40
Clutch boss	M14 × 1.0	1	50	5.0	36
Clutch spring	M 5 × 0.8	5	6	0.6	4.3
Push rod adjuster	M 6 × 1.0	1	6	0.6	4.3
Seat plate (push lever)	M 6 × 1.0	1	11	1.1	8.0
Bearing plate cover	M 6 × 1.0	6	8	0.8	5.8
Bearing plate cover (shift cam)	M 5 × 0.8	2	8	0.8	5.8
Drive sprocket	M16 × 1.0	1	60	6.0	43
Stopper lever	M 6 × 1.0	1	11	1.1	8.0
Shift arm	M 6 × 1.0	1	14	1.4	10
Joint rod 1 and shift rod	M 6 × 1.0	1	9	0.9	6.5
Joint rod 2 and shift rod	M 6 × 1.0	1	9	0.9	6.5
Joint rod 1,2	M 6 × 1.0	2	11	1.1	8.0

2



CHASSIS

Model	TZ125
Steering system: Steering bearing type	Taper roller bearing
Front suspension: Front fork travel Fork spring free length/ <Limit> Spring rate, STD Optional spring Oil capacity Oil level <Min. Max.> (From top of outer tube with inner tube and damper rod fully compressed without spring.) Oil grade Inner tube outer diameter Front fork top end	104 mm (4.09 in) 195 mm (7.68 in)/193 mm (7.60 in) K=5.88 N/mm (0.588 kg/mm, 32.9 lb/in) No 282 cm ³ (9.9 Imp oz, 9.5 US oz) 110 mm (4.33 in) 80~140 mm (3.15~5.51 in) Suspension oil "01" 36 mm (1.42 in) 15 mm (0.59 in)
Rear suspension: Shock absorber travel Spring free length Fitting length <Min. ~ Max. > Spring rate, STD Optional spring Enclosed gas pressure	50 mm (1.97 in) 130 mm (5.12 in) 120 mm (4.72 in) 110~123 mm (4.33~4.84 in) 72 N/mm (7.2 kg/mm, 403 lb/in) No 1,200 kPa (12 kg/cm ² , 171 psi)
Swingarm: Swingarm free play limit End Side clearance	<1.0 mm (0.04 in)> <0.05~0.35 mm (0.002~0.014 in)>
Wheel: Front wheel type Rear wheel type Front rim size/Material Rear rim size/Material Wheel runout limit: Vertical Lateral	Cast wheel Cast wheel 2.50 × 17/Aluminum 3.50 × 17/Aluminum <1.0 mm (0.04 in)> <0.5 mm (0.02 in)>

2



Model	TZ125
Drive chain: Type/Manufacturer Number of links Chain slack	RK415HR/RK EXCLE 115 links + Joint 30~40 mm (1.2~1.6 in)
Front disc brake: Disc outside dia. × Thickness/<Limit> Deflection limit Pad thickness <Limit> Master cylinder inside dia. Caliper cylinder inside dia. Brake fluid type	282 × 4.0 mm (11.10 × 0.16 in)/<3.5 mm (0.14 in)> 0.3 mm (0.01 in) 5.5 mm (0.22 in) <1.0 mm (0.04 in) > 12.7 mm (0.500 in) 33.96 + 27 mm (1.337 + 1.063 in) DOT #4
Rear disc brake: Disk outside dia. × Thickness/<Limit> Deflection limit Pad thickness <Limit> Master cylinder inside dia. Caliper cylinder inside dia. Brake fluid type	185 × 4.0 mm (7.28 × 0.16 in)/<3.5 mm (0.14 in)> 0.3 mm (0.01 in) 4.0 mm (0.16 in) <1.0 mm (0.04 in)> 12.7 mm (0.500 in) 25.4 mm (1.000 in) DOT #4
Brake pedal: Brake pedal position	148~152 mm (5.9~6.0 in)
Clutch lever free play/Position:	2~3 mm (0.08~0.12 in)/at lever pivot

2



Parts to be tightened	Thread size	Q'ty	Tightening torque		
			Nm	m•kg	ft•lb
△ Handle crown and outer tube	M 8 × 1.25	2	15	1.5	11
△ Under bracket and outer tube	M10 × 1.25	2	20	2.0	14
△ Handle crown and steering shaft	M14 × 1.25	1	40	4.0	29
△ Handlebar and handle bracket	M 6 × 1.0	2	8	0.8	5.8
△ Handle bracket and outer tube	M 8 × 1.25	2	15	1.5	11
△ Steering shaft pinch bolt	M 8 × 1.25	1	20	2.0	14
△ Steering ring nut	M25 × 1.0	1	Refer to NOTE		
Steering damper and frame	M 8 × 1.25	1	18	1.8	13
Steering damper and damper bracket	M 6 × 1.0	1	5	0.5	3.6
Steering damper stay and outer tube	M 6 × 1.0	1	7	0.7	5.1
Clutch lever holder	M 5 × 0.8	2	5	0.5	3.6
△ Front master cylinder and master cylinder bracket	M 6 × 1.0	2	8	0.8	5.8
Brake lever (bolt)	M 6 × 1.0	1	1	0.1	0.7
Brake lever (nut)	M 6 × 1.0	1	6	0.6	4.3
Front fork and cap bolt	M40 × 1.0	2	23	2.3	17
Front fork and damper rod	M12 × 1.25	2	40	4.0	29
Cap bolt and damper rod	M10 × 1.0	2	15	1.5	11
Front fork and front fender	M 6 × 1.0	4	8	0.8	5.8
△ Front wheel axle and nut	M14 × 1.5	1	48	4.8	35
△ Front wheel axle holder	M 8 × 1.25	2	20	2.0	14
△ Front brake disc and wheel hub	M 8 × 1.25	6	23	2.3	17
△ Brake hose (front and rear) and union bolt (master cylinder)	M10 × 1.25	2	26	2.6	19
△ Brake hose (front and rear) and adapter	M10 × 1.25	2	14	1.4	10
△ Brake caliper (front and rear) and adapter	M10 × 1.25	2	26	2.6	19
△ Front brake caliper and front fork	M10 × 1.25	2	35	3.5	25
△ Front brake caliper and pad pin	M10 × 1.25	1	10	1.0	7.2
△ Rear brake caliper and pad pin	M10 × 1.25	1	18	1.8	13
△ Front brake caliper and bleed screw	M 8 × 1.25	2	7	0.7	5.1
△ Rear brake caliper and bleed screw	M 8 × 1.25	2	6	0.6	4.3
Front brake reservoir tank and handle crown	M 6 × 1.0	1	5	0.5	3.6
Footrest bracket and frame	M 8 × 1.25	4	20	2.0	14
Footrest and footrest bracket	M 6 × 1.0	2	12	1.2	8.7
△ Brake pedal and rear master cylinder	M 6 × 1.0	1	12	1.2	8.7
△ Rear master cylinder and footrest bracket	M 8 × 1.25	2	20	2.0	14
Rear master cylinder and reservoir connector	M 4 × 0.7	1	2	0.2	1.4
Rear brake reservoir tank and frame	M 6 × 1.0	1	3	0.3	2.2
△ Rear brake caliper and caliper bracket	M 8 × 1.25	2	23	0.3	17

2

NOTE:

1. First, tighten the ring nut approximately 46 Nm (4.6 m•kg, 33 ft•lb) by using the torque wrench, then loosen the ring nut one turn.
2. Retighten the ring nut 1 Nm (0.1 m•kg, 0.7 ft•lb)



Parts to be tightened	Thread size	Q'ty	Tightening torque		
			Nm	m•kg	ft•lb
△ Rear wheel axle and nut	M18 × 1.5	1	63	6.3	45
△ Driven sprocket and bolt	M 8 × 1.25	3	32	3.2	23
△ Rear brake disc and wheel hub	M 8 × 1.25	3	23	2.3	17
Chain puller adjust bolt and locknut	M 8 × 1.25	2	16	1.6	11
Chain puller adjust bolt	M 8 × 1.25	2	2	0.2	1.4
Engine mounting					
△ Engine and frame (front)	M10 × 1.25	1	30	3.0	22
△ Engine and frame (upper)	M10 × 1.25	1	30	3.0	22
△ Engine and frame (lower)	M10 × 1.25	1	30	3.0	22
△ Pinch bolt (engine mounting bolt)	M 6 × 1.0	4	11	1.1	8.0
△ Pivot shaft and nut	M16 × 1.5	1	63	6.3	45
Pivot adjust bolt	M22 × 1.0	1	5	0.5	3.6
△ Relay arm and frame	M10 × 1.25	1	34	3.4	24
△ Relay arm and connecting rod	M10 × 1.25	1	34	3.4	24
△ Connecting rod and swingarm	M10 × 1.25	1	34	3.4	24
△ Rear shock absorber and upper bracket	M10 × 1.25	1	34	3.4	24
△ Rear shock absorber and relay arm	M10 × 1.25	1	34	3.4	24
Rear shock absorber and locknut (preload)	M46 × 1.5	1	40	4.0	29
△ Seat height adjuster and locknut	M22 × 1.0	1	38	3.8	27
△ Seat height adjuster and upper bracket	M10 × 1.25	1	30	3.0	22
Swingarm and seal guard	M 5 × 0.8	4	2	0.2	1.4
Swingarm and brake hose holder	M 6 × 1.0	2	8	0.8	5.8
Cowling stay bracket and frame	M 6 × 1.0	2	8	0.8	5.8
Cowling stay and cowling stay bracket	M 6 × 1.0	2	8	0.8	5.8
Cowling stay (left and right) and frame	M 6 × 1.0	2	8	0.8	5.8
Upper cowl and screen	M 4 × 0.7	7	4	0.4	2.9
△ Fuel tank and fuel cock	M 6 × 1.0	2	7	0.7	5.1
Rear frame and seat	M 6 × 1.0	4	8	0.8	5.8
△ Rear frame and frame	M 8 × 1.25	4	23	2.3	17
Radiator stay and frame	M 6 × 1.0	1	8	0.8	5.8

NOTE:

△ - marked portion shall be checked for torque tightening after break-in or before each race.



ELECTRICAL

Model	TZ125
Ignition system: Ignition timing (B.T.D.C) Advancer type	2.1 mm (0.083 in) Electrical
CDI: Magneto-model/Manufacturer Source coil resistance (color) Pickup coil resistance (color) CDI unit-model/Manufacturer	4JT-00/NIPPONDENSO 1.3~1.9Ω at 20°C (68°F) (White-White) 94~140Ω at 20°C (68°F) (White/Black-White/Green) 4JT-00/NIPPONDENSO
Ignition coil: Model/Manufacturer Minimum spark gap Primary winding resistance Secondary winding resistance	TJ0294/NIPPONDENSO 5 mm (0.20 in) or more 0.14~0.18Ω at 20°C (68°F) 5.0~7.4kΩ at 20°C (68°F)

2

Parts to be tightened	Thread size	Q'ty	Tightening torque		
			Nm	m•kg	ft•lb
Stator	M 6×1.0	2	7	0.7	5.1
Rotor	M12×1.25	1	53	5.3	38
Pickup coil	M 4×0.7	2	2	0.2	1.4
CDI unit	M 6×1.0	2	8	0.8	5.8
Servo motor pulley	M 5×0.8	1	8	0.8	5.8
Servo motor	M 6×1.0	2	8	0.8	5.8
Ignition coil	M 6×1.0	2	8	0.8	5.8
Voltage regulator	M 6×1.0	2	7	0.7	5.1



CABLE ROUTING DIAGRAM

- ① Front brake hose
- ② Throttle cable
- ③ Clamp
- ④ YPVS cable
- ⑤ Clutch cable
- ⑥ Band
- ⑦ Frame
- ⑧ Cable

- A Do not cut the end of the clamp.
- B Install the clamp with its open ends facing upward.
- C Cut the band so that the protruding portion is less than 5 mm (0.20 in).

2

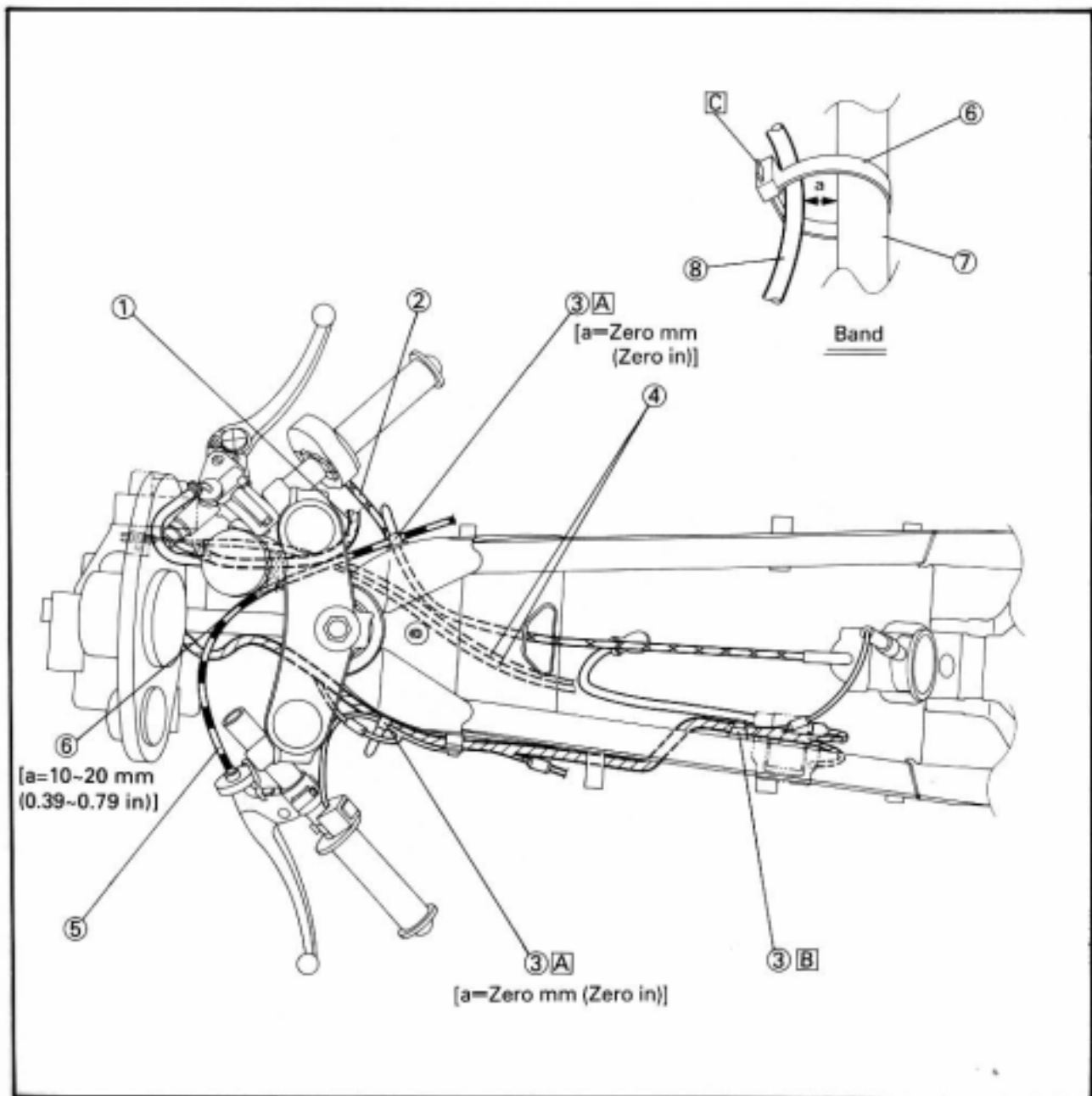

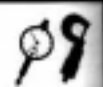

- ① Tachometer
- ② Water temperature gauge
- ③ Band
- ④ CDI unit
- ⑤ Condenser
- ⑥ "ENGINE STOP" button
- ⑦ Clamp
- ⑧ CDI magneto lead

- A Install the tachometer and water temperature gauge with their figures standing upright.
- B Route the water temperature gauge conductor so that the conductor does not contact the cowling and others.
- C Align the white tape on the wireharness with the CDI unit mounting boss.
- D Install the CDI magneto lead so that it is not loose.

2

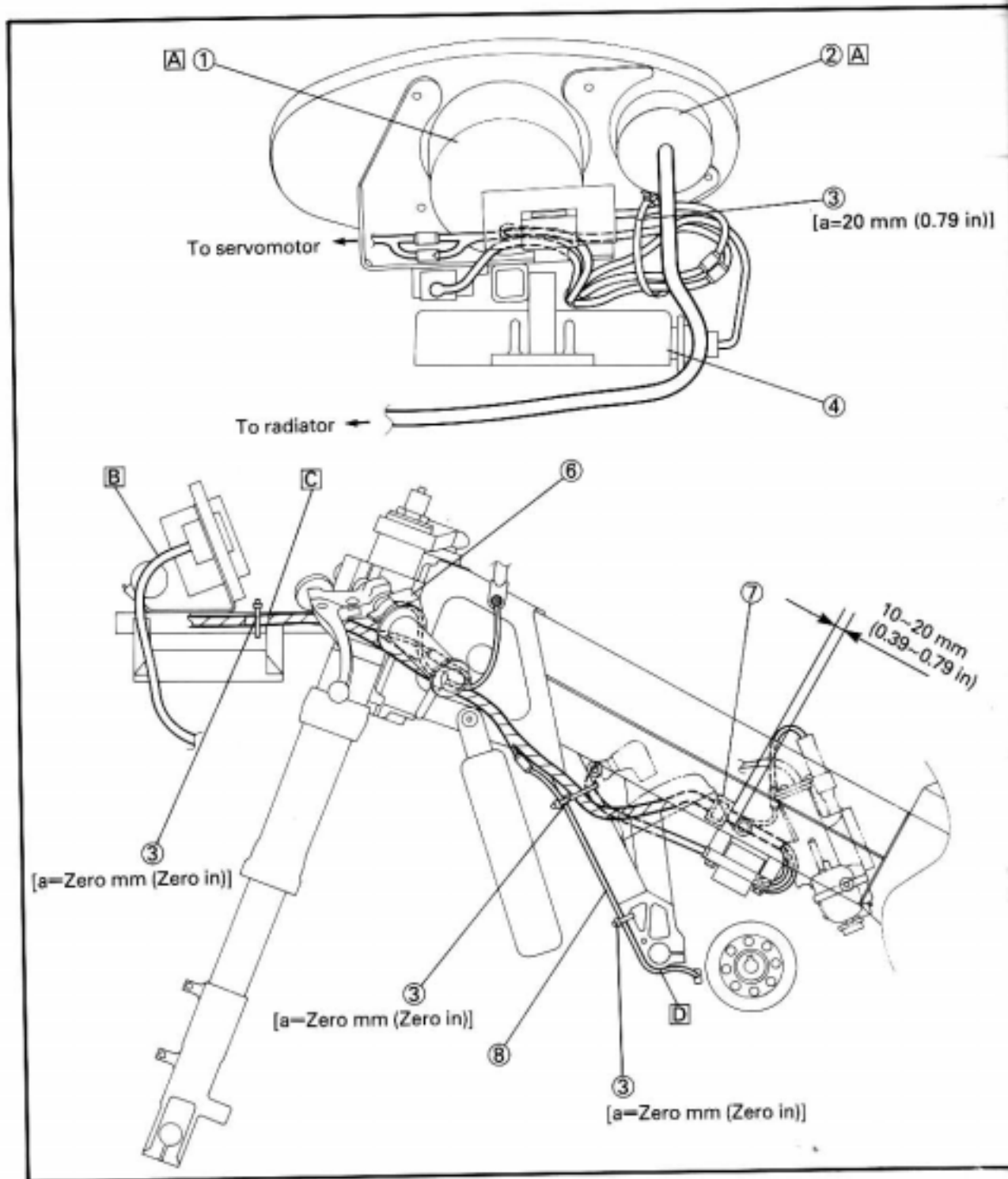

CABLE ROUTING DIAGRAM

SPEC



- ① YPVS cable 1 (silver)
- ② YPVS cable 2 (black)
- ③ Throttle cable
- ④ Servo motor
- ⑤ Band
- ⑥ Front brake hose
- ⑦ Clamp
- ⑧ Clutch cable

- A Position the end of the band to the front of the front fork.
- B Be sure the brake hose is not twisted.
- C Do not tighten the band too much.
- D Clamp the clutch cable at its adjusting portion.

2

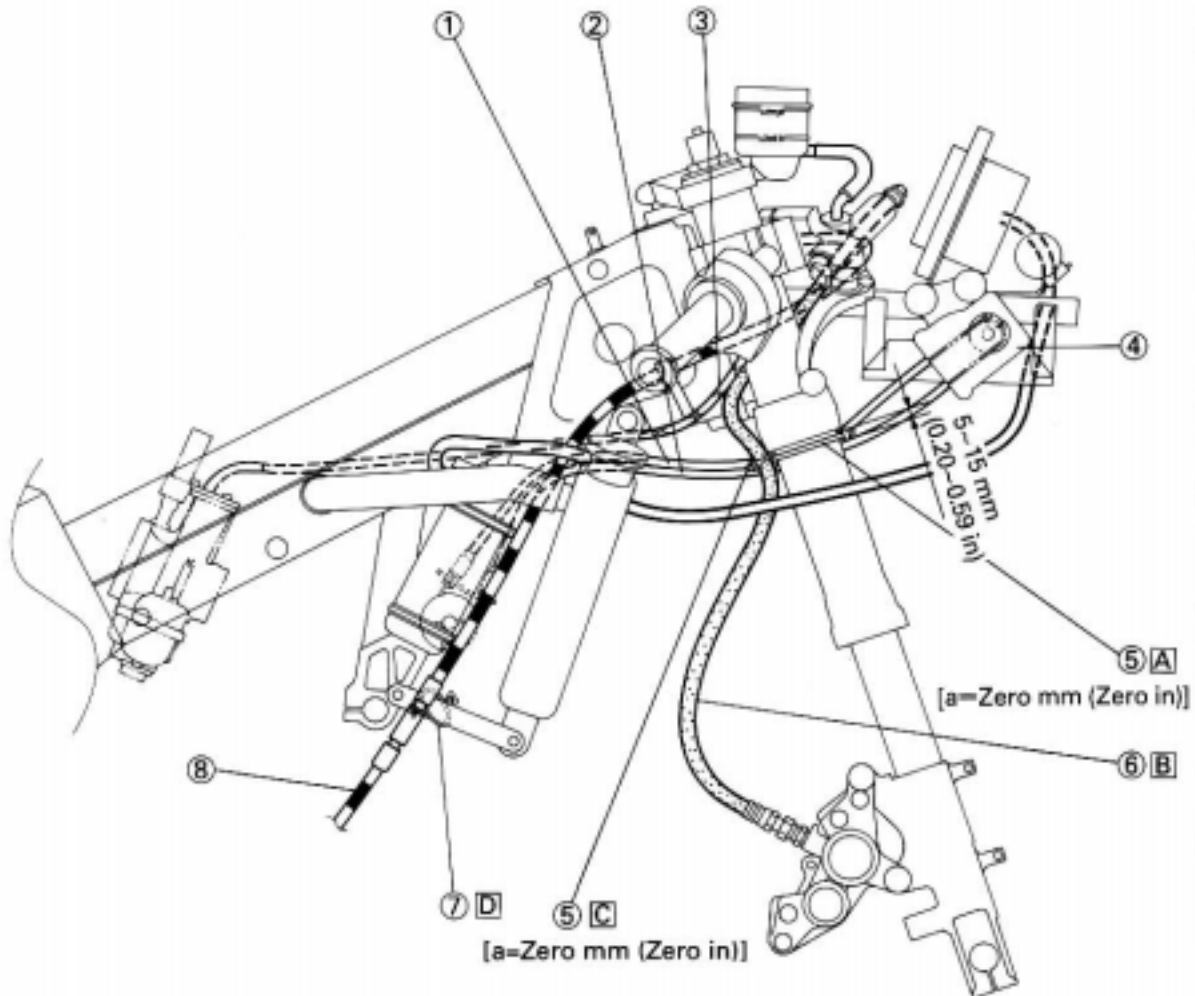



- ① Brake hose holder
- ② Reservoir hose
- ③ Rear brake hose
- ④ Clamp

- A Position the reservoir hose with the white paint facing upward.
- B Be sure the brake hose is not twisted.
- C Do not cut the end of the clamp.

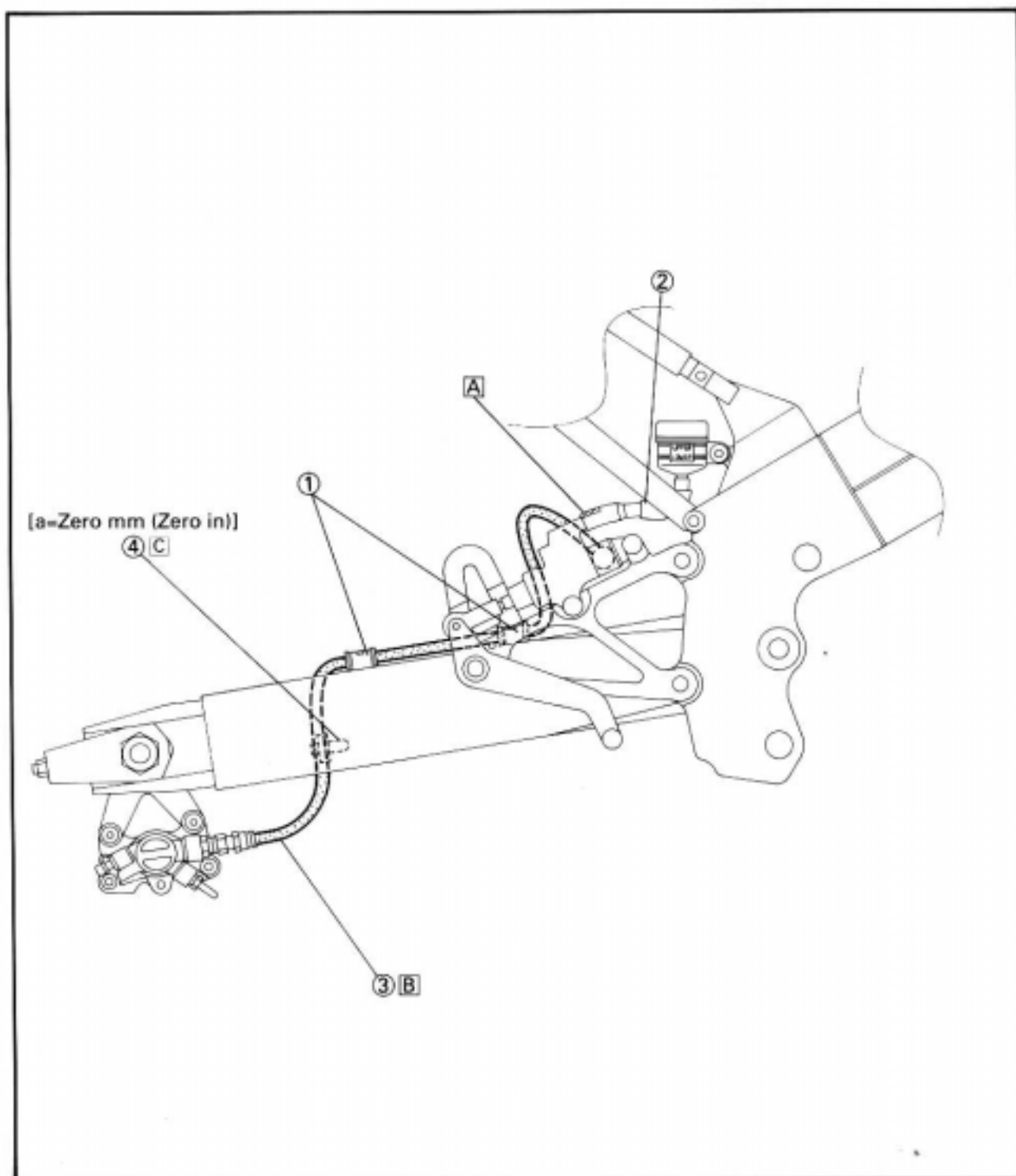
2

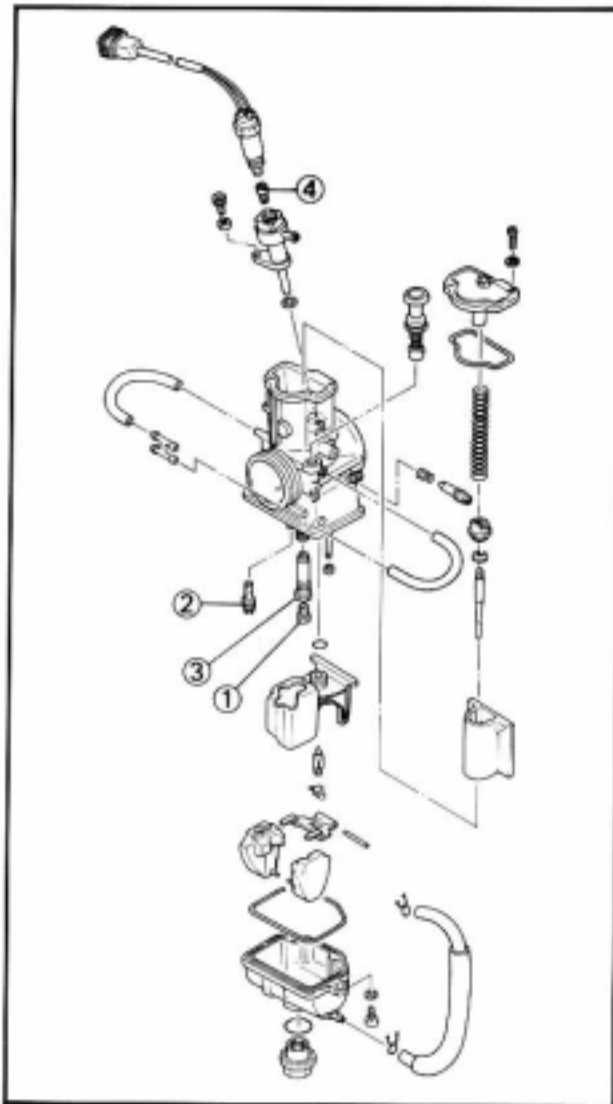

SETTING PARTS

NOTE:

For detail setting, refer to TUNING section in CHAPTER 7.

CARBURETOR

Part name	Size	Part number	
Main jet ①	#330	137-14143-66	
	#340	137-14143-68	
	#350	137-14143-70	
	#360	137-14143-72	
	#370	137-14143-74	
	#380	137-14143-76	
	#390	137-14143-78	
	#400	137-14143-80	
	#410	137-14143-82	
	#420	137-14143-84	
	#430	137-14143-86	
	#440	137-14143-88	
	#450	137-14143-90	
	#460	137-14143-92	
	#470	137-14143-94	
#480	137-14143-96		
#490	137-14143-98		
#500	137-1414K-00		
#520	137-1414K-04		
#540	137-1414K-08		
*	#560	137-1414K-12	
Pilot jet ②	#17.5	193-14142-17	
	*	#20	193-14142-20
Main nozzle ③	R-3	3TC-14141-R3	
	R-4	3TC-14141-R4	
	R-5	3TC-14141-R5	
	*	R-7	3TC-14141-R7
Power jet ④	#55	3G2-14231-11	
	*	#60	3G2-14231-12
	#65	3G2-14231-13	

*Factory installed

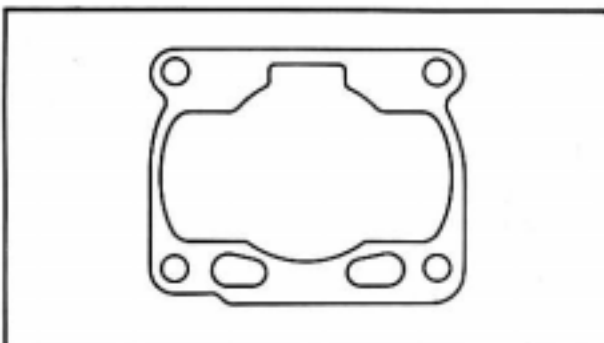

CYLINDER GASKET

Part number	Size (thickness)
4JT-11351-00 *	t = 0.8 mm
4JT-11351-10	t = 0.7 mm
4JT-11351-20	t = 0.6 mm

* Factory installed

2



2

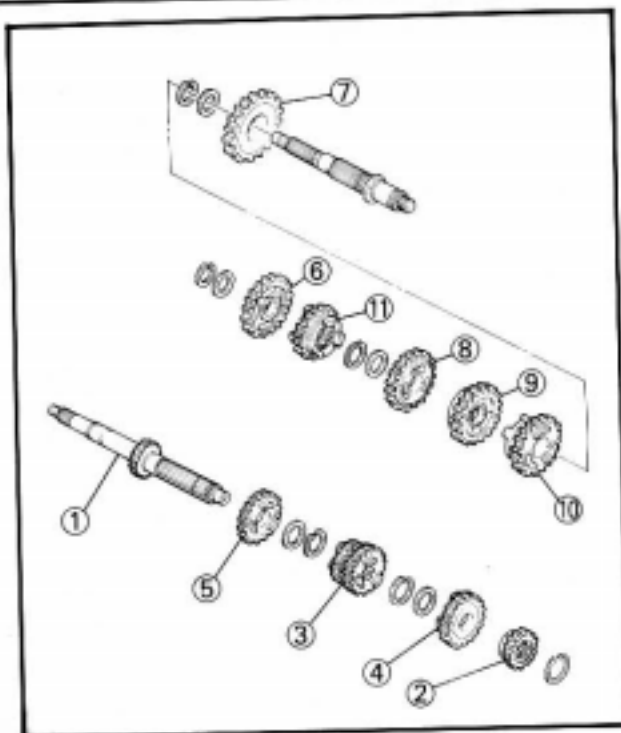

TRANSMISSION

Part name	Size	Part number
Main axle ① *	15T	4JT-17411-00
2nd pinion gear ② *	21T	4JT-17121-00
	17T	4JT-17121-10
	20T	4JT-17121-20
3rd/4th pinion gear ③ *	16T/22T	4JT-17131-00
	19T/22T	4JT-17131-10
	19T/20T	4JT-17131-20
5th pinion gear ④ *	26T	4JT-17151-00
	23T	4JT-17151-10
	21T	4JT-17151-20
6th pinion gear ⑤ *	21T	4JT-17161-00
	27T	4JT-17161-10
	22T	4JT-17161-20
1st wheel gear ⑥ *	30T	4JT-17211-00
	29T	4JT-17211-10
2nd wheel gear ⑦ *	35T	4JT-17221-00
	27T	4JT-17221-10
	30T	4JT-17221-20
3rd wheel gear ⑧ *	23T	4JT-17231-00
	26T	4JT-17231-10
	25T	4JT-17231-20
4th wheel gear ⑨ *	28T	4JT-17241-00
	27T	4JT-17241-10
	24T	4JT-17241-20
5th wheel gear ⑩ *	30T	4JT-17251-00
	26T	4JT-17251-10
	23T	4JT-17251-20
6th wheel gear ⑪ *	23T	4JT-17261-00
	29T	4JT-17261-10

* Factory installed

DRIVE, DRIVEN SPROCKET AND DRIVE CHAIN

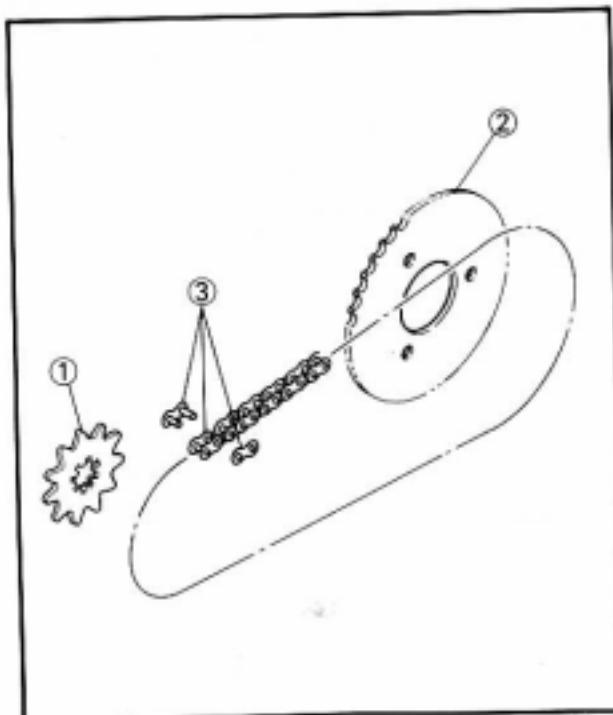

Part name	Size	Part number
Drive sprocket ① *	16T	938AA-16198
	17T	938AA-17196
	18T	938AA-18199
Driven sprocket ② *	35T	4JT-25435-00
	36T	4JT-25436-00
	37T	4JT-25437-00
	38T	4JT-25438-00
	39T	4JT-25439-00
Drive chain ③ *	116 links	94561-46116
	120 links	94561-45120

* Factory installed

MAINTENANCE INTERVALS

The following schedule is intended as a general guide to maintenance and lubrication. Bear in mind that such factors as weather, terrain, geographical location, and individual usage will alter the required maintenance and lubrication intervals. If you are a doubt as to what intervals to follow in maintaining and lubricating your machine, consult your Yamaha dealer.

3

Item	After break-in	Every race	Every 500 km	Every 1,000 km	As required	Recommend lubricant
PISTON Inspect and clean Replace	●	●	●		●	Inspect crack Remove carbon
PISTON PIN, SMALL END BEARING Inspect Replace	●	●	● (Piston pin)	● (Bearing)		
PISTON RING Inspect Replace	●	●	●		●	Check ring end gap
CYLINDER HEAD Inspect and clean Retighten	● ●	● ●				Remove carbon Check O-ring
CYLINDER Inspect and clean Replace	●	●			●	Seizure Wear
Y.P.V.S Inspect Retighten	● ●	● ●				
CLUTCH Inspect and adjust Replace	●	●			●	
TRANSMISSION Replace oil Inspect transmission	●		●		●	Castrol R30
OIL PUMP STRAINER Clean	●		●			
SHIFT FORK, SHIFT CAM, GUIDE BAR Inspect					●	Inspect wear
ROTOR NUT Retighten				●		
MUFFLER Inspect Clean	●	●			●	Inspect crack
CRANK Inspect and replace				● (1,500 km)	●	
CARBURETOR Inspect, adjust and clean	●	●				
SPARK PLUG Inspect and clean Replace	●	●			●	
PLUG CAP Inspect and replace				● (1,500 km)	●	

MAINTENANCE INTERVALS



Item	After break-in	Every race	Every 500 km	Every 1,000 km	As required	Recommend lubricant
DRIVE CHAIN Lubricate, slack, alignment Replace	●	●		●		Use chain lube Chain slack: 30 – 40 mm (1.2 – 1.6 in)
DRIVE SPROCKET Inspect and replace					●	Wear
COOLING SYSTEM Check cooling level and leakage Check radiator cap operation Replace cooling water Replace hoses	●	●			● ● ●	
OUTSIDE NUTS AND BOLTS Retighten	●	●				Refer to the "STARTING AND BREAK-IN" in CHAPTER 1. GENERAL INFORMATION.
FRAME Clean and inspect	●	●				Inspect crack
FUEL TANK, COCK Clean and inspect	●	●				
BRAKES Check free play Check brake disc surface Check brake fluid level and leakage Retighten brake disc bolts, caliper bolts and master cylinder bolts Replace pads Replace brake fluid	● ● ● ●	● ● ● ●			● ●	Every one year
FRONT FORKS Inspect Replace oil Replace oil seal	●	●		●	●	Suspension oil "01"
REAR SHOCK ABSORBER Inspect and adjust Lube Retighten	● ●	●	●		(After rain race) ●	Lithium base grease
SWINGARM Inspect and retighten Lube	●	●			●	Lithium base grease
RELAY ARM, CONNECTING ROD Inspect and retighten Lube	●	●			●	Lithium base grease
CHAIN GUARD Replace					●	
STEERING HEAD Inspect free play and retighten Clean and lube Replace bearings	●	●		●	●	Lithium base grease

3

MAINTENANCE INTERVALS

INSP
ADJ



Item	After break-in	Every race	Every 500 km	Every 1,000 km	As required	Recommend lubricant
TIRE, WHEELS Inspect air pressure, wheel run-out and tire wear Inspect bearings and sprocket damper Clean and lube Retighten sprocket damper Replace bearings, sprocket and sprocket damper	●	●	● ●		●	Lithium base grease
THROTTLE, CONTROL CABLE Check routing and connection Lubricate	● ●	● ●				Yamaha cable lube or SAE 10W30 motor oil

3

LOCKING WIRE INSTALLATION GUIDE

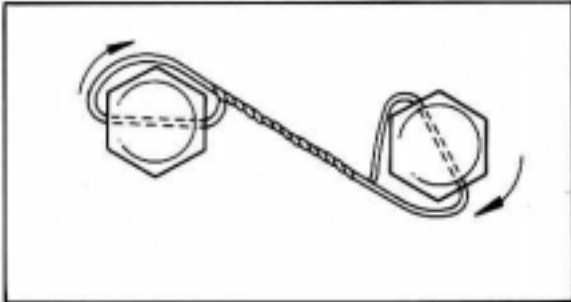

Bolt to bolt

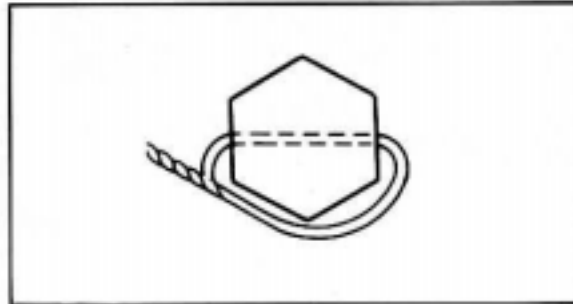

Bolt

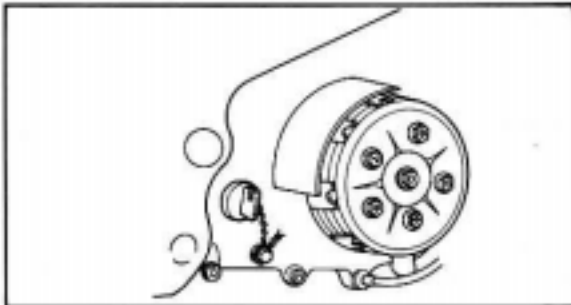

Oil filler cap and check bolt

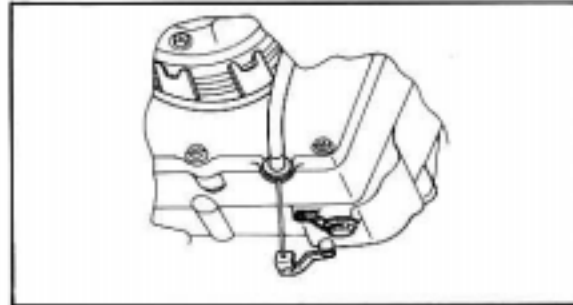

Oil drain bolt

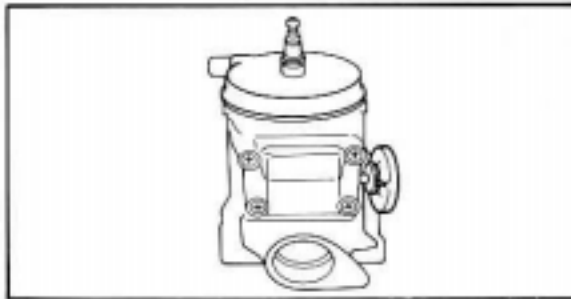

YPVS pulley

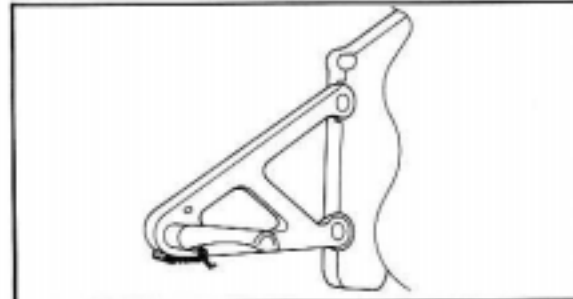

Footrest

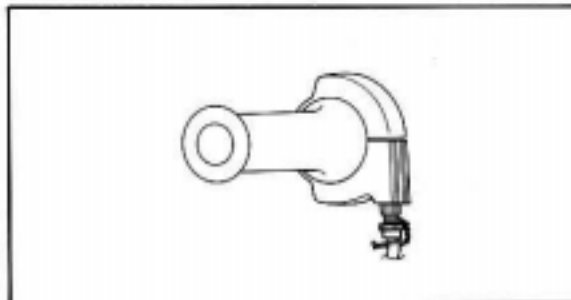

Throttle cable adjuster

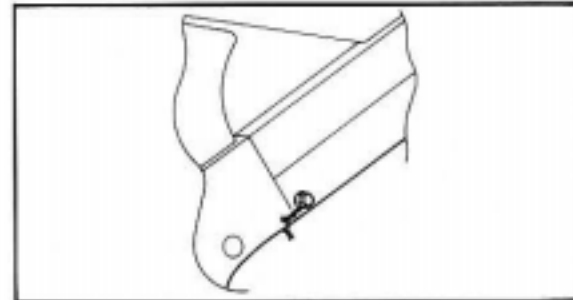

Tank rail drain bolt

3



COOLING WATER LEVEL INSPECTION

CAUTION: _____

- The cooling system is filled with coolant at the factory to prevent rusting. Be sure to replace coolant with soft water before riding.
- Hard water or salt water is harmful to the engine parts. You may use distilled water, if you can't get soft water.

⚠ WARNING _____

Do not remove the radiator cap ①, drain bolt and hoses when the engine and radiator are hot. Scalding hot fluid and steam may be blown out under pressure, which could cause serious injury.

When the engine has cooled, place a thick towel over the radiator cap, slowly rotate the cap counterclockwise to the detent. This procedure allows any residual pressure to escape. When the hissing sound has stopped, press down on the cap while turning counterclockwise and remove it.

3

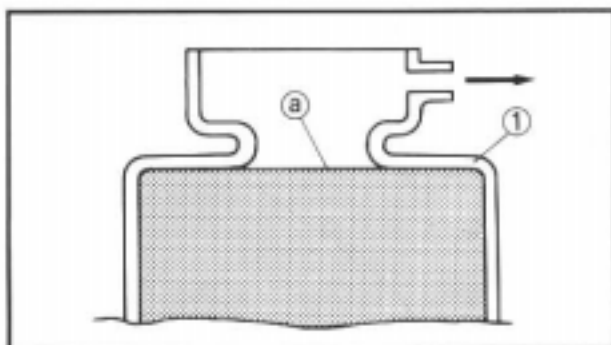

1. Place the machine on a level place, and hold it in an upright position.
2. Remove:
 - Radiator cap
3. Check:
 - Cooling water level (a)
 Cooling water level low → Add cooling water.

① Radiator

COOLING WATER REPLACEMENT

⚠ WARNING _____

Do not remove the radiator cap when the engine is hot.

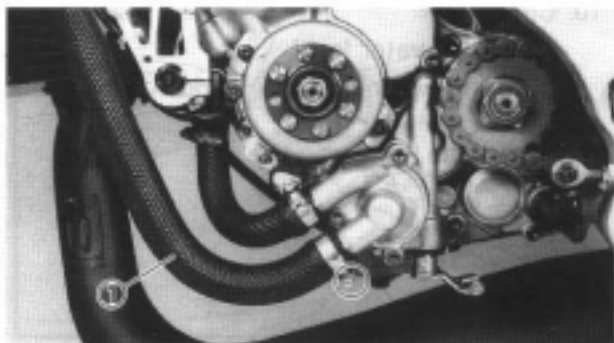
**CAUTION:**

Take care so that cooling water does not splash on painted surfaces. If it splashes, wash it away with water.

1. Remove the lower cowl.
2. Place a container under the radiator hose.
3. Disconnect:
 - Radiator hose 2 ①
4. Remove:
 - Radiator cap
 Drain the cooling water completely.
5. Clean:
 - Cooling system
 Thoroughly flush the cooling system with clean tap water.
6. Connect:
 - Radiator hose 2



Radiator hose clamp:
2 Nm (0.2 m·kg, 1.4 ft·lb)

7. Fill:
 - Radiator
 - Engine
 To specified level.



Recommended cooling water:
Soft water
Cooling water capacity:
0.89 L (0.78 Imp qt, 0.94 US qt)

CAUTION:

Hard water or salt water is harmful to the engine parts. You may use distilled water, if you can't get soft water.

8. Fill:
 - Radiator
 - Engine
 To specified level.
9. Install:
 - Radiator cap
 Start the engine and warm it up for a several minute.

3



10. Check:
 - Cooling water level
Cooling water level low→Add cooling water.
11. Install the lower cowl.

3

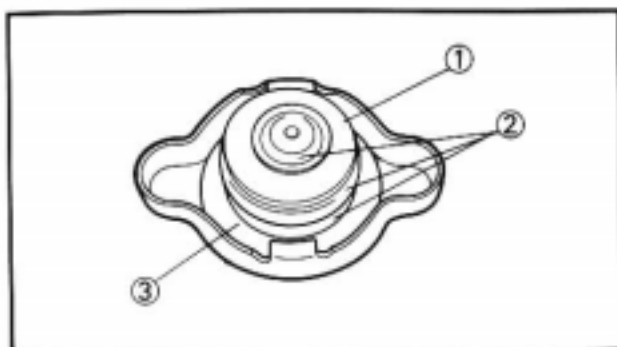

RADIATOR CAP INSPECTION

1. Inspect:
 - Seal (radiator cap) ①
 - Valve and valve seat ②
Crack/Damage→Replace.
Exist fur deposits ③→Clean or replace.

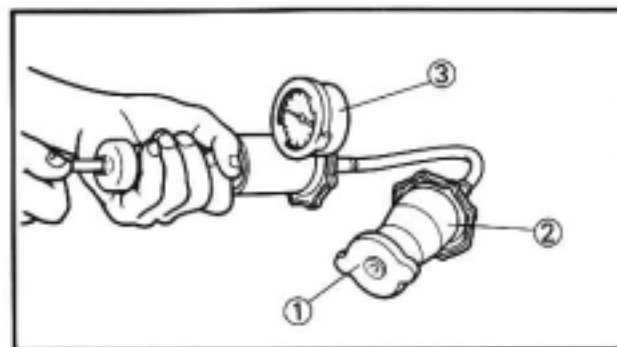

RADIATOR CAP OPENING PRESSURE INSPECTION

1. Attach:
 - Radiator cap tester ③ and adapter ②



Radiator cap tester:
YU-24460-1/90890-01325
Adapter:
YU-33984/90890-01352

NOTE: _____
Apply water on the radiator cap seal.

- ① Radiator cap
2. Apply the specified pressure.



Radiator cap opening pressure:
95~125 kPa (0.95~1.25 kg/cm²,
13.5~17.8 psi)

3. Inspect:
 - Pressure
Impossible to maintain the specified pressure
for 10 seconds→Replace.



10. Check:
 - Cooling water level
Cooling water level low→Add cooling water.
11. Install the lower cowl.

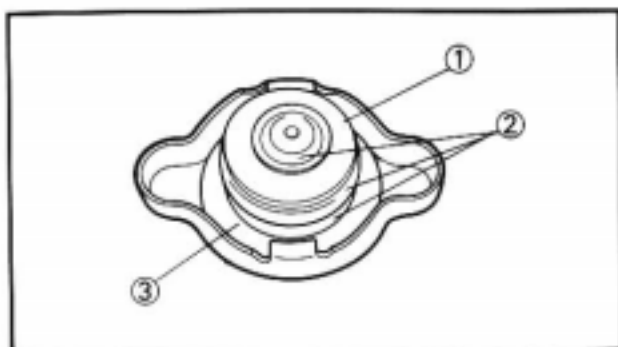

RADIATOR CAP INSPECTION

1. Inspect:
 - Seal (radiator cap) ①
 - Valve and valve seat ②
Crack/Damage→Replace.
Exist fur deposits ③→Clean or replace.

RADIATOR CAP OPENING PRESSURE INSPECTION

1. Attach:
 - Radiator cap tester ③ and adapter ②

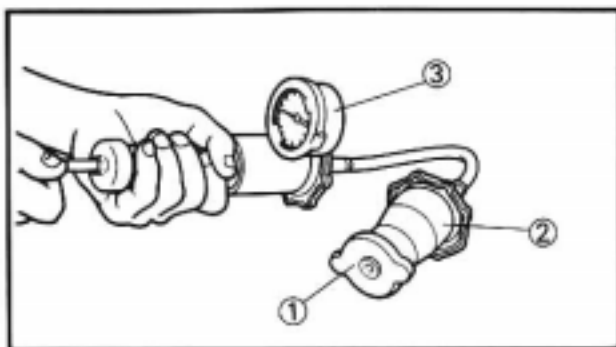

Radiator cap tester:
YU-24460-1/90890-01325
Adapter:
YU-33984/90890-01352

NOTE: _____
Apply water on the radiator cap seal.

- ① Radiator cap
2. Apply the specified pressure.



Radiator cap opening pressure:
95~125 kPa (0.95~1.25 kg/cm²,
13.5~17.8 psi)

3. Inspect:
 - Pressure
Impossible to maintain the specified pressure
for 10 seconds→Replace.

3

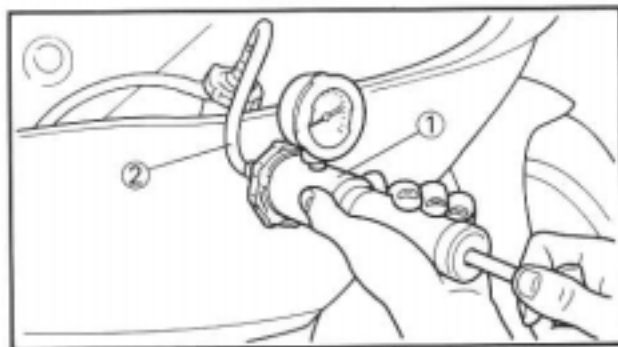

COOLING SYSTEM INSPECTION

1. Inspect:
 - Coolant level
2. Attach:
 - Radiator cap tester ① and adapter ②



Radiator cap tester:
YU-24460-1/90890-01325
Adapter:
YU-33984/90890-01352

3. Apply the specified pressure.



Standard pressure:
180 kPa (1.8 kg/cm², 25.6 psi)

NOTE:

- Do not apply pressure more than specified pressure.
- Radiator should be filled fully.

3

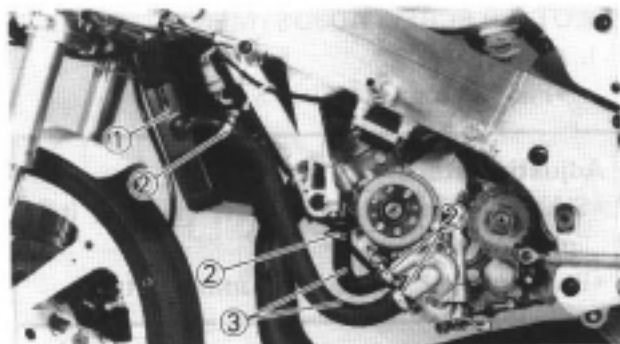

4. Inspect:
 - Pressure
Impossible to maintain the specified pressure for 10 seconds → Repair.
 - Radiator ①
 - Radiator hose joints ②
 - Radiator hose ③
Swelling → Replace.

CLUTCH CARE

NOTE:

This machine is equipped with a dry type clutch. Be sure to clean with solvent or replace if grease or oil contacts either clutch or friction plates.

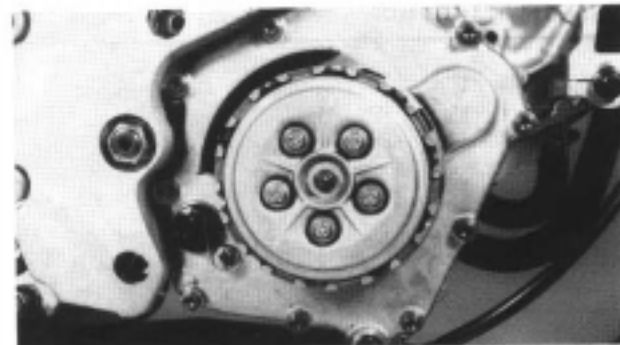

CLUTCH ADJUSTMENT

1. Check:
 - Clutch lever free play ①
Out of specification → Adjust



Clutch lever free play ①:
2 ~ 3 mm (0.08 ~ 0.12 in)

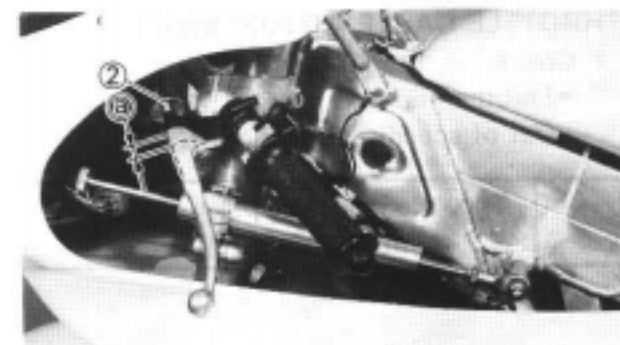

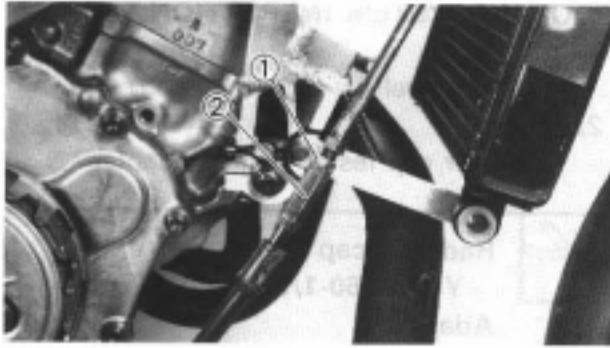

2. Adjust:
- Clutch lever free play

Clutch lever free play adjustment steps:

- Loosen the locknut ①.
- Turn the adjuster ② until free play a is within the specified limits.
- Tighten the locknut.

NOTE:

After adjustment, check proper operation of clutch lever.

3

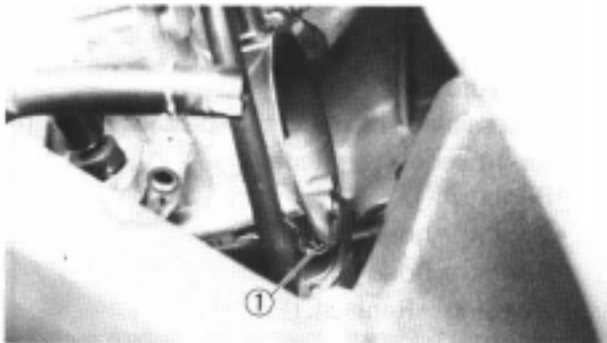

PILOT AIR SCREW ADJUSTMENT

1. Adjust:
- Pilot air screw ①

Adjusting steps:

- Screw in the pilot air screw ① until it is lightly seated.
- Back out by the specified number of turns.

Pilot air screw:
1-1/2 turn out

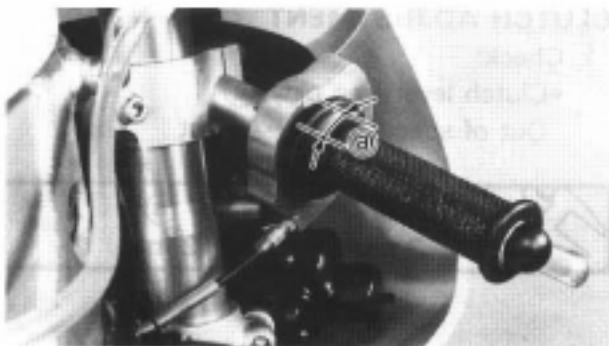

THROTTLE CABLE ADJUSTMENT

1. Check:
- Throttle grip free play a
- Out of specification → Adjust.



Throttle grip free play a :
2~4 mm (0.08~0.16 in)

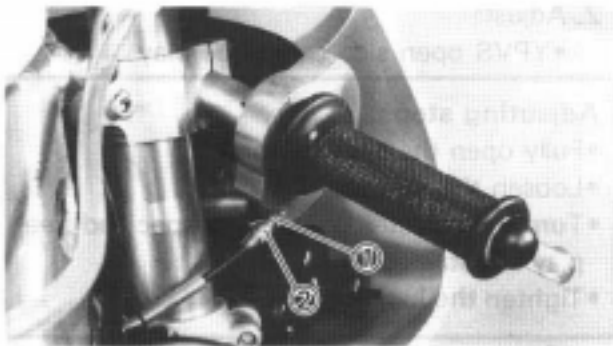

2. Adjust:
- Throttle cable free play (a)

Throttle cable free play adjustment steps:

- Loosen the locknut (1).
- Turn the adjuster (2) until the specified free play is obtained.
- Tighten the locknut.

⚠ WARNING

After adjusting, turn the handlebar to right and left and make sure that the engine idling does not run faster.

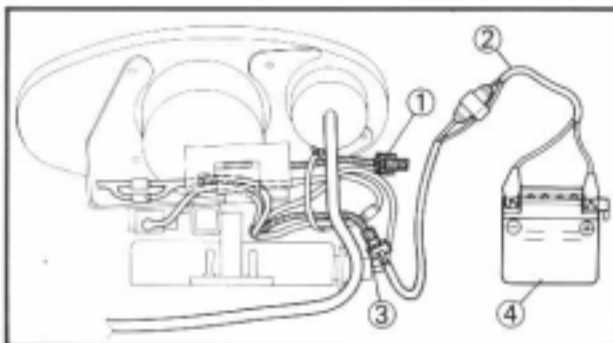
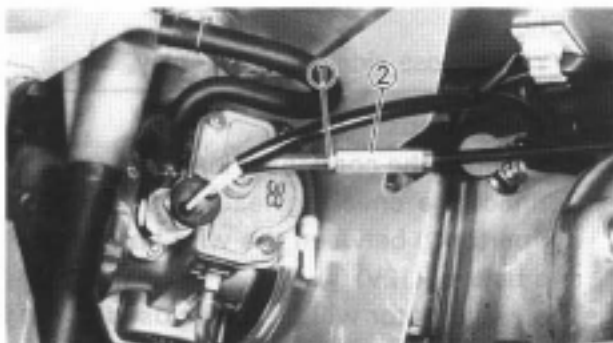

YPVS OPEN SIDE CABLE ADJUSTMENT

1. Check:
- YPVS open side cable free play

Checking steps:

- Disconnect the condenser lead (1).
- Connect the checking lead (with supplying parts) (2) between the wire harness (3) and battery (12V) (4).
- The servomotor will be fully opened.

NOTE:

After the battery is connected, the servomotor will be operated as follows.

1. The servomotor will be fully closed about 1 second.
2. And then, it will be kept fully opened.

- Check the free play (a) for the YPVS open side cable (5).
Out of specification → Adjust.

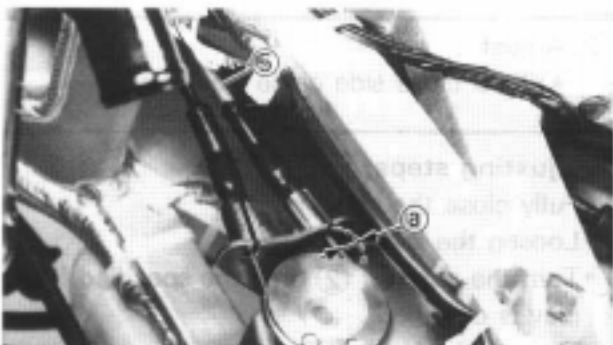

**YPVS open side cable:
free play (a):
2-3 mm (0.08-0.12 in)**

3

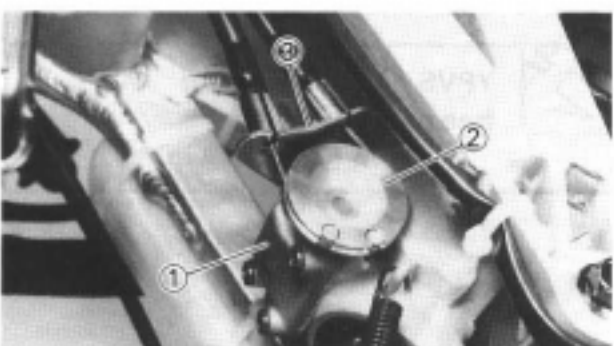
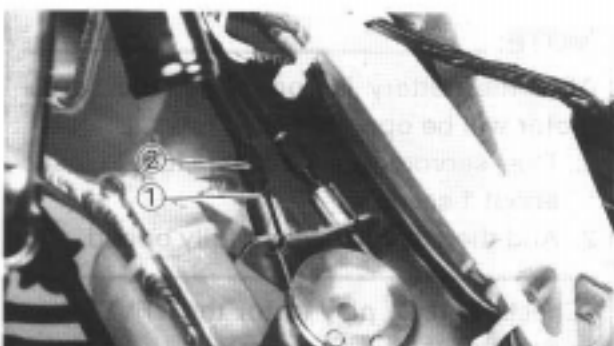
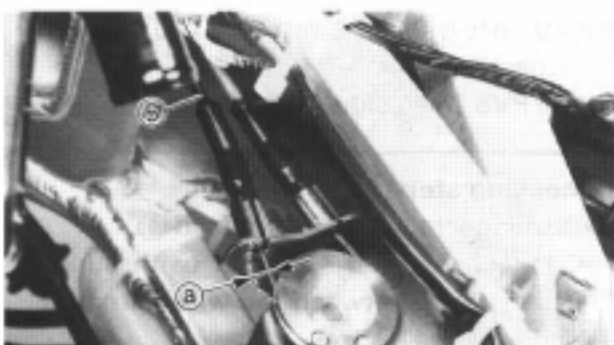
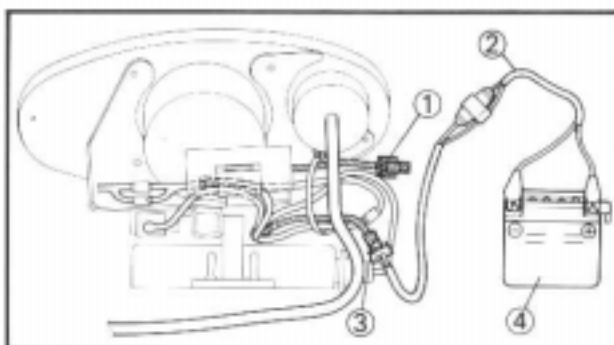
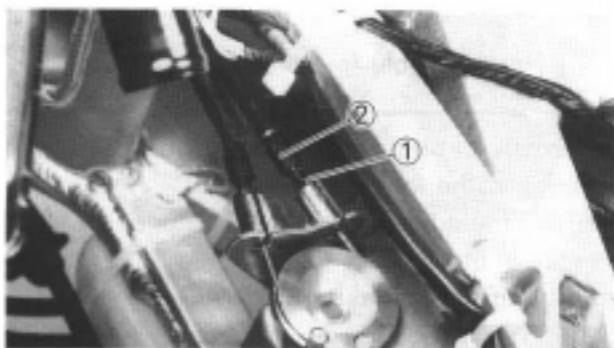

2. Adjust:

- YPVS open side cable free play

Adjusting steps:

- Fully open the servomotor.
- Loosen the locknut (1).
- Turn the adjuster (2) until the specified free play is obtained.
- Tighten the locknut.

YPVS CLOSE SIDE CABLE ADJUSTMENT

1. Check:

- YPVS close side cable free play

Checking steps:

- Disconnect the condenser lead (1).
 - Connect the checking lead (with supplying parts) (2) between the wire harness (3) and battery (12V) (4).
 - The servomotor will be fully closed about 1 second.
 - During this 1 second, disconnect the battery.
 - The servomotor will be kept fully closed.
 - Check the free play (a) for the YPVS close side cable (5).
- Out of specification → Adjust.



**YPVS close side cable:
free play (a):**

2~3 mm (0.08~0.12 in)

2. Adjust:

- YPVS close side cable free play

Adjusting steps:

- Fully close the servomotor.
- Loosen the locknut (1).
- Turn the adjuster (2) until the specified free play is obtained.
- Tighten the locknut.

YPVS COMPONENTS RETIGHTENING

NOTE:

Before riding the machine, retighten all YPVS components.

1. Retighten:

- Valve cover (1)
- Pulley (2)
- Cable stay (3)

3



- Screw (valve cover):
4 Nm (0.4 m•kg, 2.9 ft•lb)
- Screw (pulley):
4 Nm (0.4 m•kg, 2.9 ft•lb)
- Bolt (cable stay):
7 Nm (0.7 m•kg, 5.1 ft•lb)

TRANSMISSION OIL LEVEL CHECK

1. Start the engine, warm it up for several minutes and wait for five minutes.
2. Place the machine on a level place and hold it up on upright position by placing the suitable stand.

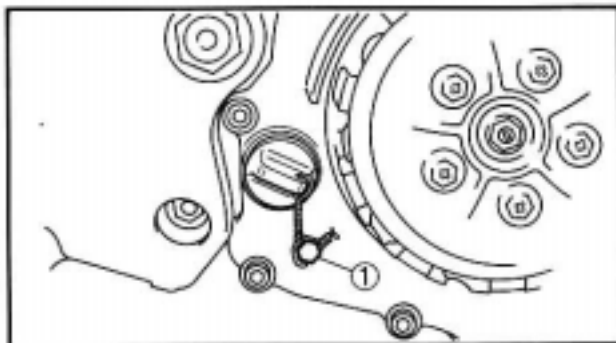

3. Check:
 - Transmission oil level

3

Transmission oil level checking steps:

- Remove the checking bolt ①.
- Inspect the oil level.

NOTE: _____

Be sure the machine is positioned straight up when inspecting the oil level.

⚠ WARNING _____

Never attempt to remove the checking bolt just after high speed operation. The heated oil could spout out, causing danger. Wait until the oil cools down.

Oil flows out → Oil level is correct.
 Oil does not flow out → Oil level is low.
 Add transmission oil until oil flows out.

- Inspect the gasket (oil check bolt), replace if damaged.
- Tighten the oil check bolt.



- Oil check bolt:
9 Nm (0.9 m•kg, 6.5 ft•lb)

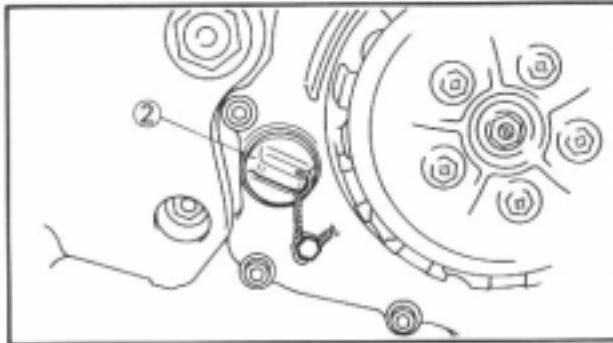
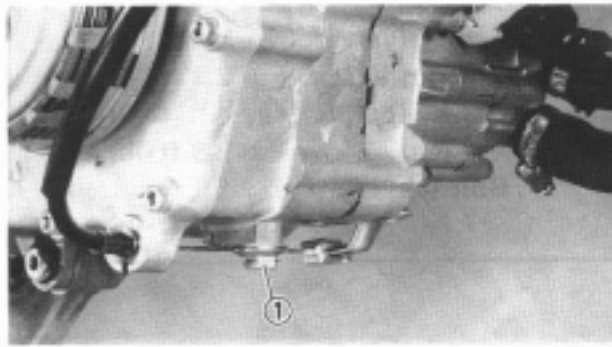

TRANSMISSION OIL REPLACEMENT

1. Start the engine and warm it up for several minutes and wait for five minutes.
2. Place the machine on a level place and hold it on upright position by placing the suitable stand.
3. Place a suitable container under the engine.
4. Remove:
 - Exhaust pipe
 - Drain bolt ①
 - Oil filler cap ②
 Drain the transmission oil.
5. Install:
 - Drain bolt ①
 - Exhaust pipe

 **Drain bolt:**
23 Nm (2.3 m•kg, 17 ft•lb)

6. Fill:
 - Transmission oil

 **Recommended oil:**
Castrol R30
Oil capacity
(periodic oil change):
0.30 L (0.26 Imp qt, 0.32 US qt)

7. Check:
 - Oil leakage
8. Check:
 - Transmission oil level
9. Install:
 - Oil filler cap ②



BRAKE SYSTEM AIR BLEEDING

⚠ WARNING

Bleed the brake system if:

- The system has been disassembled.
- A brake hose has been loosened or removed.
- The brake fluid is very low.
- The brake operation is faulty.

A dangerous loss of braking performance may occur if the brake system is not properly bled.

1. Bleed:
 - Brake fluid

- A** Front
B Rear

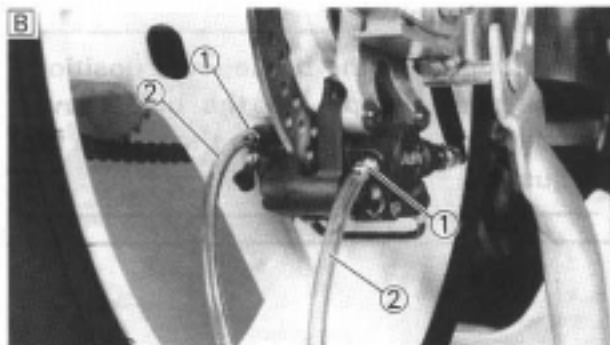
Air bleeding steps:

- a. Add proper brake fluid to the reservoir.
- b. Install the diaphragm. Be careful not to spill any fluid or allow the reservoir to overflow.
- c. Connect the clear plastic tube **②** tightly to the caliper bleed screw **①**.
- d. Place the other end of the tube into a container.
- e. Slowly apply the brake lever or pedal several times.
- f. Pull the lever in or push down on the pedal. Hold the lever or pedal in position.
- g. Loosen the bleed screw and allow the lever or pedal to travel towards its limit.
- h. Tighten the bleed screw when the lever or pedal limit has been reached; then release the lever or pedal.

Bleed screw (front):

7 Nm (0.7 m·kg, 5.1 ft·lb)

Bleed screw (rear):

6 Nm (0.6 m·kg, 4.3 ft·lb)

- i. Repeat steps (e) to (h) until of the air bubbles have been removed from the system.

NOTE:

If bleeding is difficult, it may be necessary to let the brake fluid system stabilize for a few hours.

Repeat the bleeding procedure when the tiny bubbles in the system have disappeared.

- j. Add brake fluid to the level line on the reservoir.

3

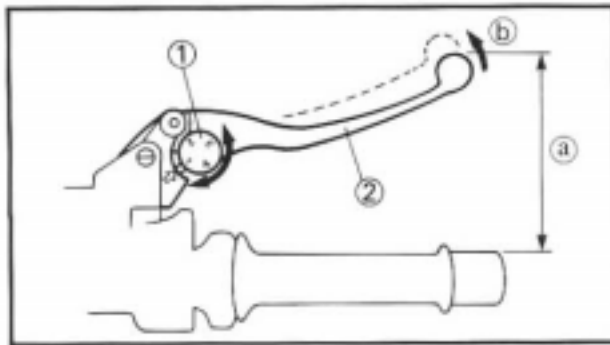

FRONT BRAKE ADJUSTMENT

1. Adjust:

- Brake lever position (a)

Adjustment steps:

- Turn the adjuster (1) while pushing the brake lever (2) forward (b) until the desired lever position is obtained.

Adjuster position #1 → Brake lever position (a) is the largest.

Adjuster position #4 → Brake lever position (a) is the smallest.

The distance (a) becomes about 5 mm (0.20 in) shorter when the adjuster number is advanced by one.

⚠ WARNING

After adjusting the brake lever position, make sure the pin on the brake lever holder is firmly inserted in the hole in the adjuster.

3

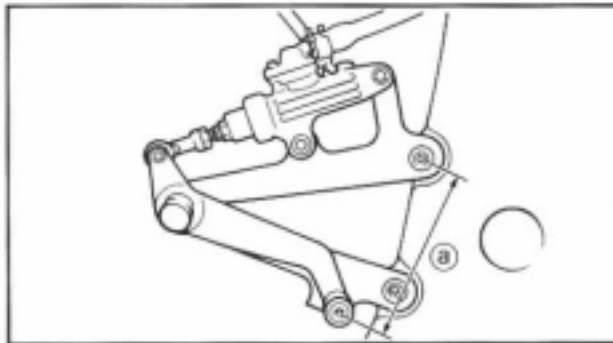

REAR BRAKE ADJUSTMENT

1. Check:

- Brake pedal height (a)
- Out of specification → Adjust.



Brake pedal height (a):
148–152 mm (5.9–6.0 in)

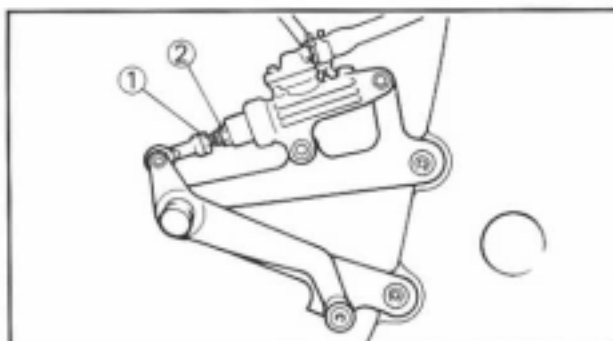

2. Adjust:

- Brake pedal height

Pedal height adjustment steps:

- Loosen the locknut (1).
- Turn the adjusting nut (2) until the pedal height (a) is within specified height.
- Tighten the locknut.

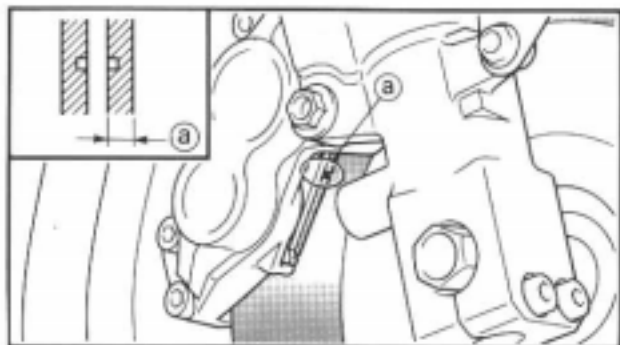

FRONT BRAKE PAD INSPECTION AND REPLACEMENT

- Inspect:
 - Brake pad thickness (a)
 Out of specification → Replace as a set.

Brake pad thickness (a):	
Standard	<Limit>
5.5 mm (0.22 in)	1.0 mm (0.04 in)

- Replace:
 - Brake pad

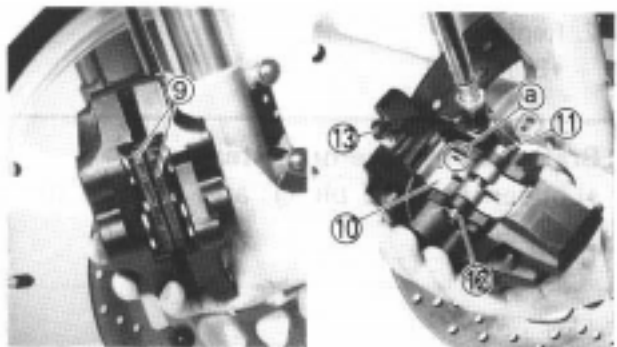
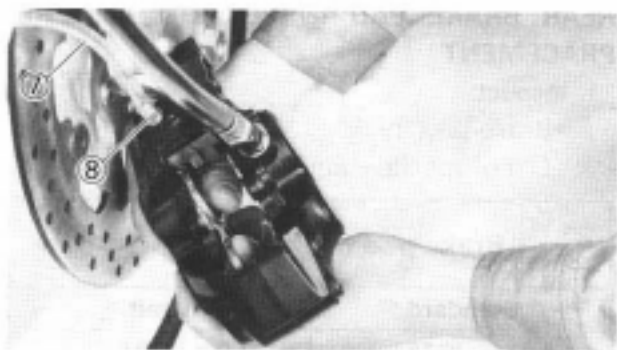
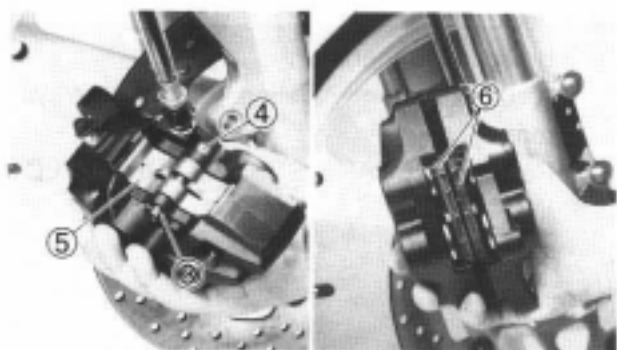
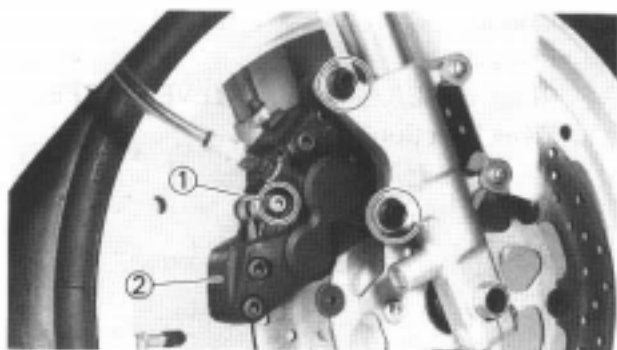

Brake pad replacement steps:

- Loosen the pad pin (1) and remove the caliper (2).
- Remove the clip (3), pad pin (4), pad support (5) and brake pads (6).
- Connect the transparent hose (7) to the bleed screw (8) and place the suitable container under its end.
- Loosen the bleed screw and push the caliper piston in.

CAUTION:

Do not reuse the drained brake fluid.

- Tighten the bleed screw.



Bleed screw:

7 Nm (0.7 m·kg, 5.1 ft·lb)

- Install the brake pads (9), pad support (10), pad pin (11) and clip (12).

NOTE:

- When installing the pad support, its arrow mark (a) facing the bleed screw (13).
- Temporarily tighten the pad pin at this point.

3

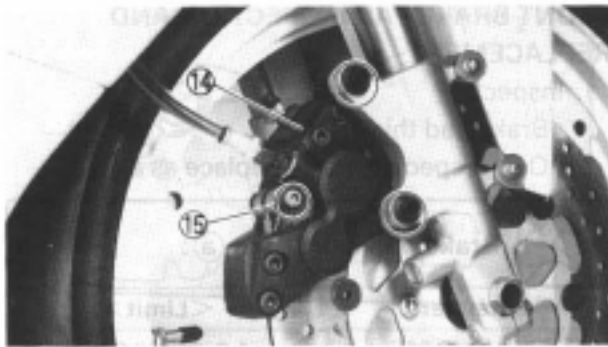

- Install the caliper ⑭ and tighten the pad pin ⑮.



Bolt (caliper):
35 Nm (3.5 m·kg, 25 ft·lb)
Pad pin:
10 Nm (1.0 m·kg, 7.2 ft·lb)

3. Inspect:
 - Brake fluid level
Refer to "BRAKE FLUID LEVEL INSPECTION" section.

3

4. Check:
 - Brake lever operation
A softy or spongy feeling → Bleed brake system.
Refer to "BRAKE SYSTEM AIR BLEEDING" section.

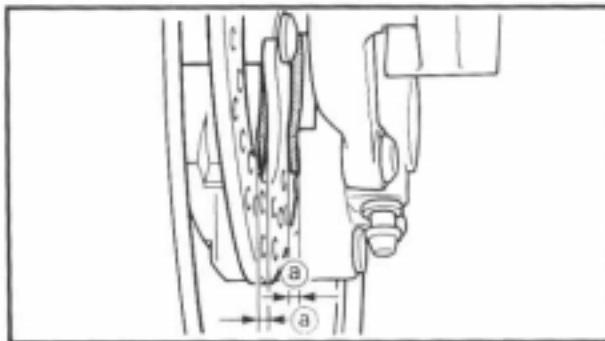

REAR BRAKE PAD INSPECTION AND REPLACEMENT

1. Inspect:
 - Brake pad thickness ①
Out of specification → Replace as a set.



Brake pad thickness ①:

Standard	<Limit>
4.0 mm (0.16 in)	1.0 mm (0.04 in)

2. Replace:
 - Brake pad



Brake pad replacement steps:

- Loosen the pad pin ① and remove the caliper ②.

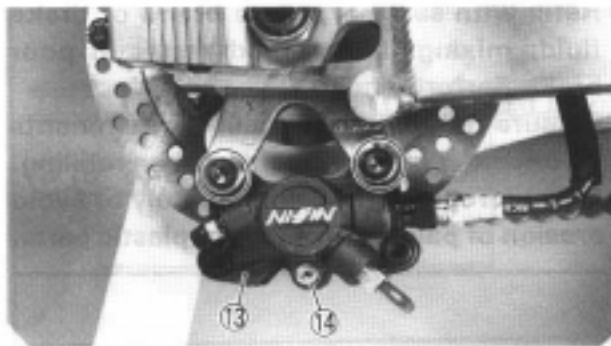
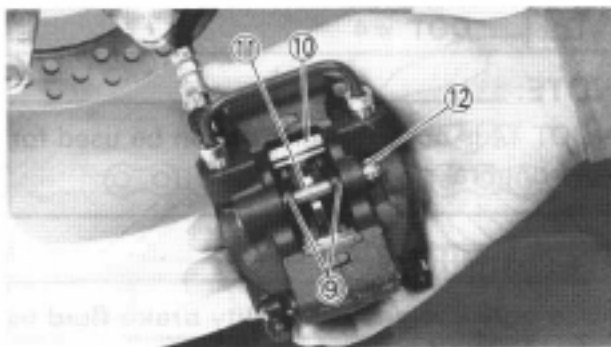
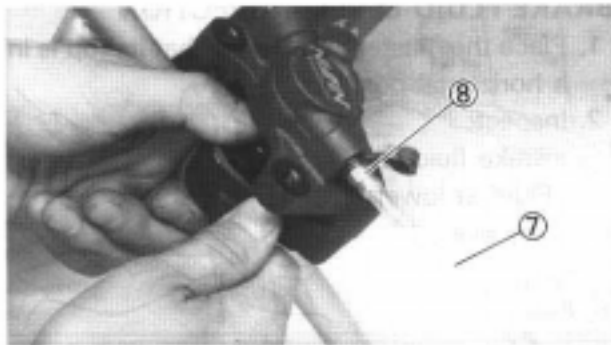
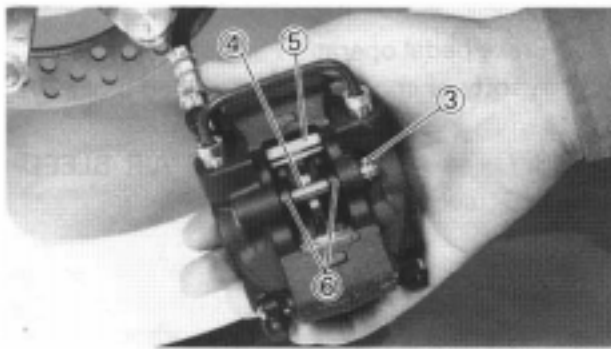

- Remove the cotter pin (3), pad pin (4), pad support (5) and brake pads (6).
- Connect the transparent hose (7) to the bleed screw (8) and place the suitable container under its end.
- Loosen the bleed screw and push the caliper piston in.

CAUTION:

Do not reuse the drained brake fluid.

- Tighten the bleed screw.



Bleed screw:

6 Nm (0.6 m·kg, 4.3 ft·lb)

- Install the brake pads (9), pad support (10), pad pin (11) and cotter pin (12).

NOTE:

- Always use a new cotter pin.
- Temporarily tighten the pad pin at this point.
- Install the caliper (13) and tighten the pad pin (14).



Bolt (caliper):

23 Nm (2.3 m·kg, 17 ft·lb)

Pad pin:

18 Nm (1.8 m·kg, 13 ft·lb)

3

3. Inspect:

- Brake fluid level
Refer to "BRAKE FLUID LEVEL INSPECTION" section.

3

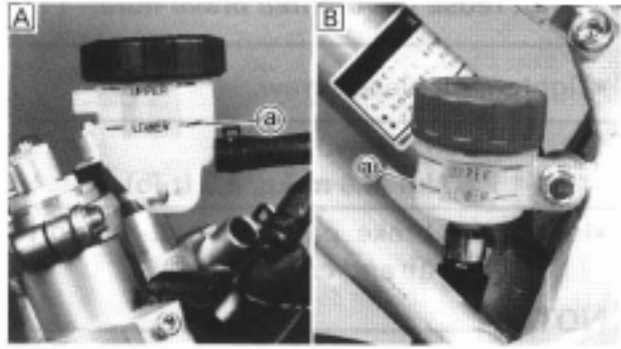

4. Check:
- Brake pedal operation
A softy or spongy feeling → Bleed brake system.
Refer to "BRAKE SYSTEM AIR BLEEDING" section.

BRAKE FLUID LEVEL INSPECTION

1. Place the master cylinder so that its top is in a horizontal position.
2. Inspect:
 - Brake fluid level
Fluid at lower level → Fill up.

Ⓐ Lower level

Ⓐ Front
Ⓑ Rear

	Recommended brake fluid: DOT #4
--	--

NOTE: _____

If DOT #4 is not available, #3 can be used for the front brake only.

⚠ WARNING _____

- Use only designated quality brake fluid to avoid poor brake performance.
- Refill with same type and brand of brake fluid; mixing fluids could result in poor brake performance.
- Be sure that water or other contaminants do not enter master cylinder when refilling.
- Clean up spilled fluid immediately to avoid erosion of painted surfaces or plastic parts.

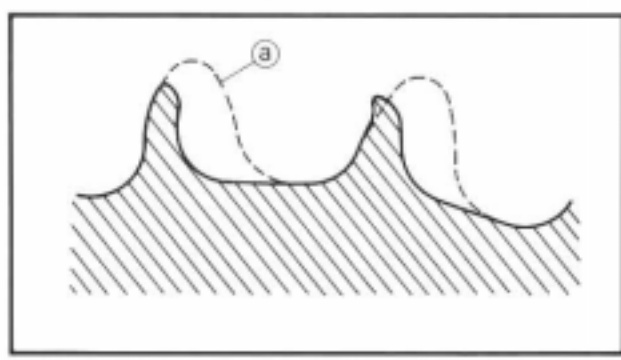

SPROCKETS INSPECTION

1. Inspect:
 - Sprocket teeth Ⓐ
Excessive wear → Replace.

NOTE: _____

Replace the drive, driven sprockets and drive chain as a set.

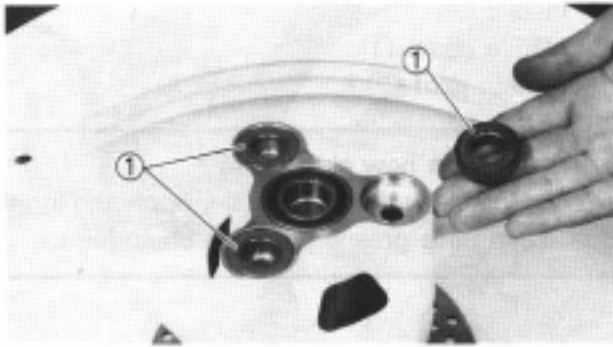

2. Inspect:
- Sprocket damper ①
Wear/Damage→Replace.

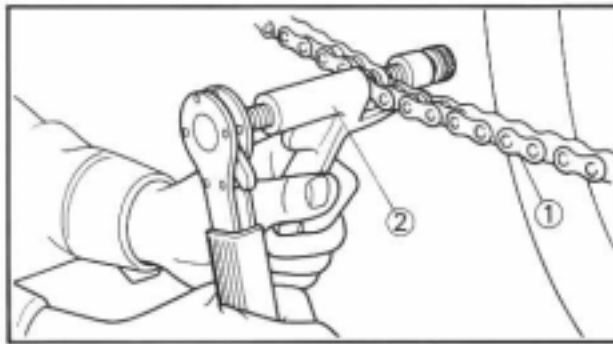

DRIVE CHAIN INSPECTION

1. Remove:
- Drive chain ①

NOTE: _____
Remove the drive chain using a chain cutter ②.

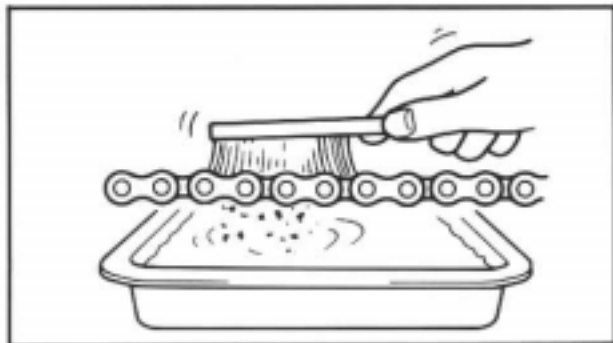

2. Clean:
- Drive chain
Place it in kerosene, and brush off as much dirt as possible. Then remove the chain from the kerosene and dry the chain.

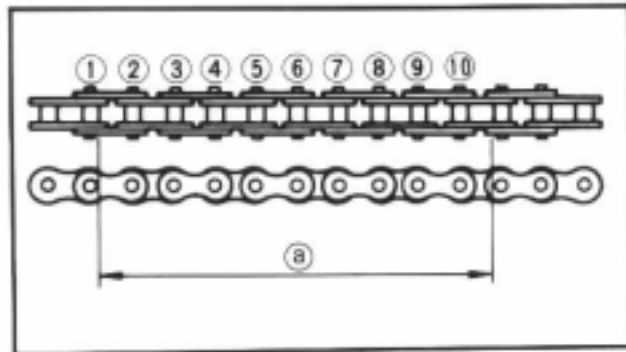

3. Measure:
- Drive chain length (10 links) ①
Out of specification→Replace.

 Drive chain length (10 links):
Limit: 122.8 mm (4.835 in)

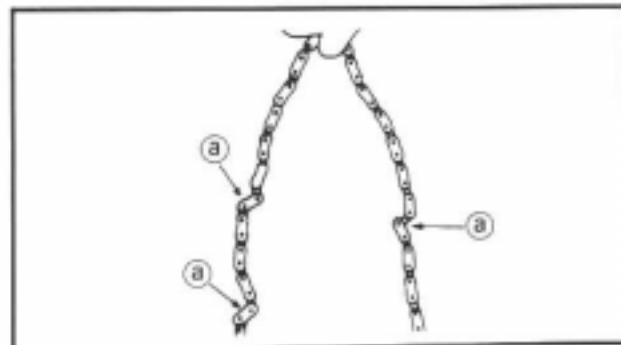

4. Check:
- Drive chain stiffness ①
Clean and oil the chain and hold as illustrated.
Stiff→Replace drive chain.

3

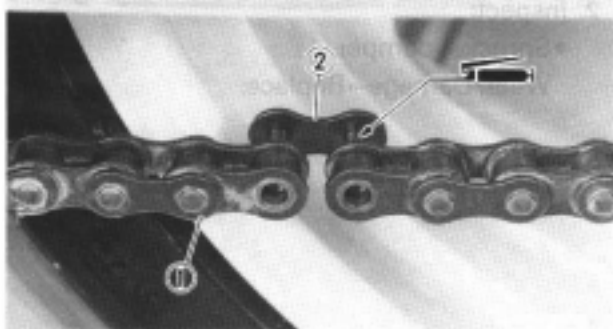

5. Install:

- Drive chain ①
- Chain joint ②

NOTE: _____

- Always use a new chain joint.
- When installing the drive chain, apply the lithium soap base grease onto the chain joint.

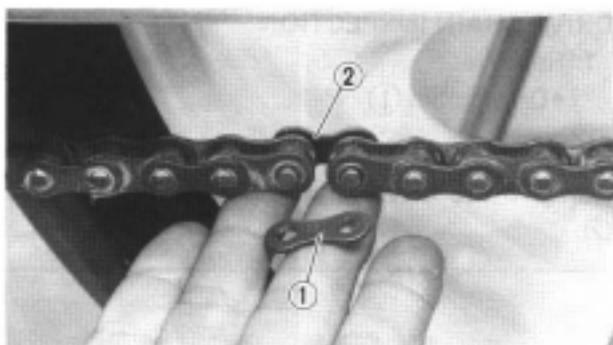

6. Install:

- Link plate ①

NOTE: _____

- Press the link plate onto the chain joint ② using a chain rivetter ③.
- Rivet the end of the chain joint using a chain rivetter ④.
- After rivetting the chain joint, make sure its movement is smooth.

3

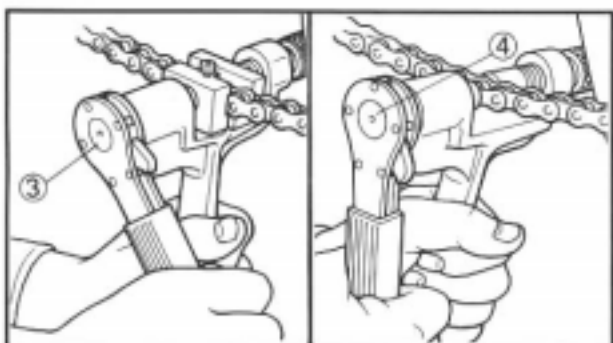

7. Lubricate:

- Drive chain



Drive chain lubricant:

SAE 10W30 motor oil or suitable chain lubricants



DRIVE CHAIN SLACK ADJUSTMENT

1. Hold the machine on upright position by placing the suitable stand.
2. Check:
 - Drive chain slack (a)
 - Out of specification → Adjust.

 **Drive chain slack:**
30 ~ 40 mm (1.2 ~ 1.6 in)

NOTE: _____

Before checking and/or adjusting, rotate the rear wheel through several revolutions and check the slack several times to find the tightest point. Check and/or adjust chain slack with rear wheel in this "tight chain" position.

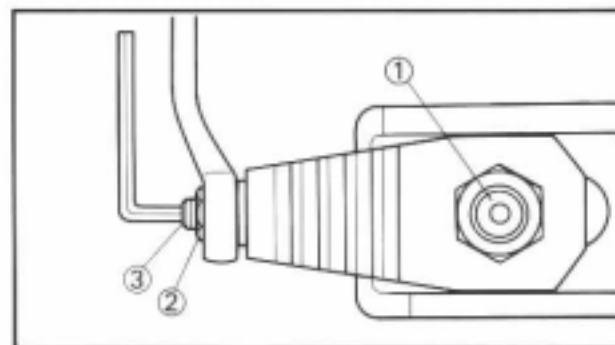
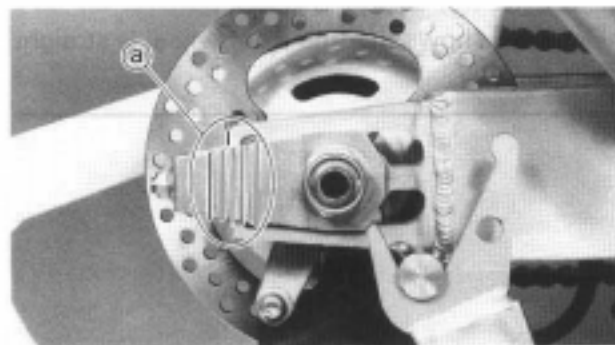
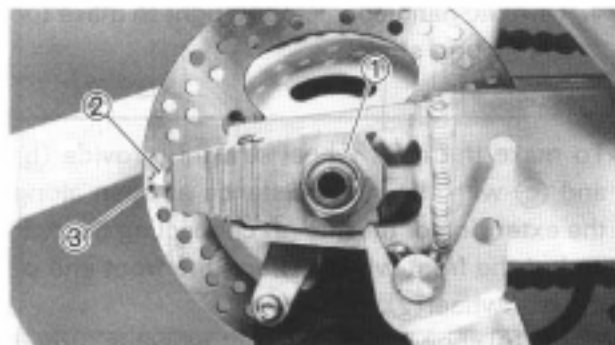

2. Adjust:
 - Drive chain slack

Drive chain slack adjustment steps:

- Loosen the axle nut (1) and locknuts (2).
- Adjust chain slack by turning the adjusters (3).

To Tighten → Turn adjuster (3) counter-clockwise.

To Loosen → Turn adjuster (3) clockwise.

- Turn each adjuster exactly the same amount to maintain correct axle alignment. (There are marks (a) on each side of chain puller alignment.)

NOTE: _____

Turn the adjusters so that the chain is in line with the sprocket, as viewed from the rear.

CAUTION: _____

Too small chain slack will overload the engine and other vital parts; keep the slack within the specified limits.

- Tighten the axle nut while pushing down the drive chain.

 **Axle nut:**
63 Nm (6.3 m • kg, 45 ft • lb)

3



- Turn out the adjusters to the specified torque.



Adjuster:
2 Nm (0.2 m•kg, 1.4 ft•lb)

- Tighten the locknuts.



Locknut:
16 Nm (1.6 m•kg, 11 ft•lb)

3

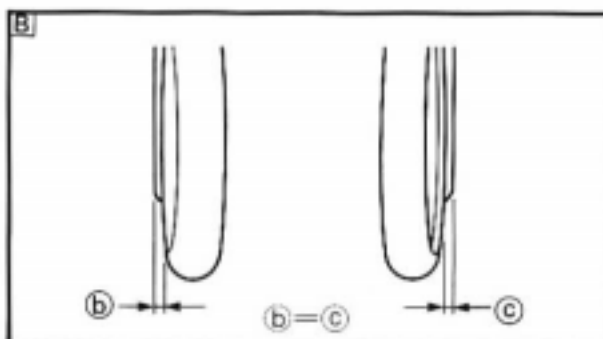
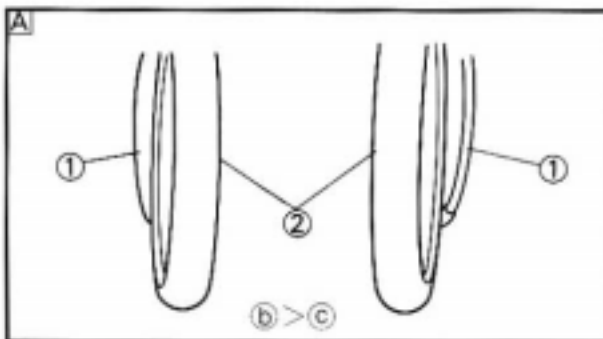
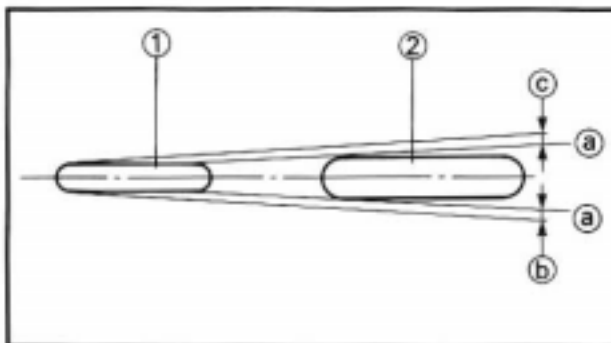

WHEEL ALIGNMENT ADJUSTMENT

1. Remove:
 - Lower cowl
2. Place the machine on a level place and hold it up on upright position.
3. Sit 1–2 m (3.3–6.6 ft) behind the machine and look at both sides of the wheels below the rear wheel axle.
4. Turn the handlebar left and right to make the front wheel straight.

NOTE:

- To make the front wheel straight, provide (b) and (c) with the same distance as seen along the extension of the line (a) connecting the rear end of the front wheel (1) and the front end of the rear wheel (2).
- Figure **A** shows that the front wheel is turned clockwise ($b > c$).
- Figure **B** shows that the front wheel is straight ($b = c$).

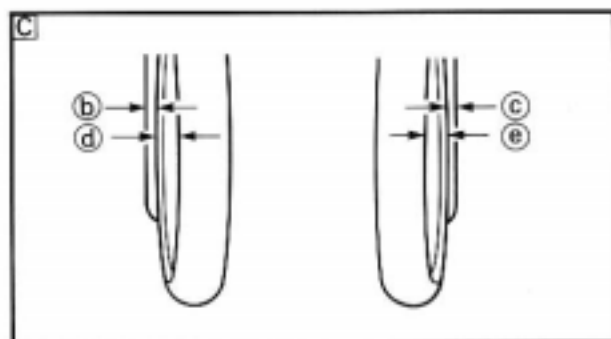
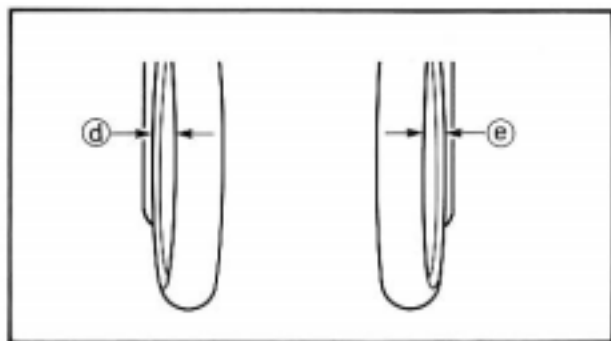
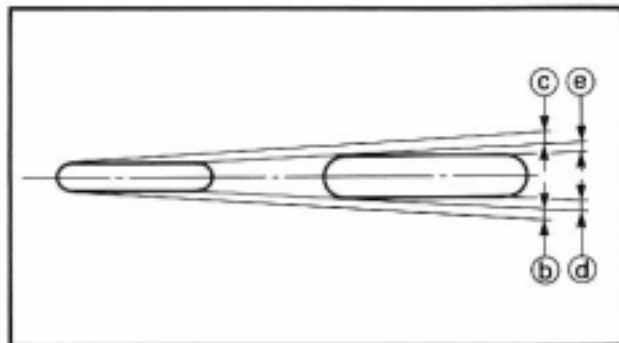

5. Check:

- Wheel alignment

With the front wheel straight ($(b) = (c)$), check whether the distances (d) and (e) are equal.

If not—Adjust.

6. Adjust:

- Wheel alignment

Turn the chain puller adjuster while paying attention to the drive chain slack and make adjustment while moving the rear wheel.

NOTE:

- Figure **C** shows that the wheel alignment has been correctly made ($(b) = (c)$ and $(d) = (e)$).
- After the adjustment, record the difference in the graduation between the left and right chain pullers as it will provide convenience in your future similar adjustment.

7. Install:

- Lower cowl

3

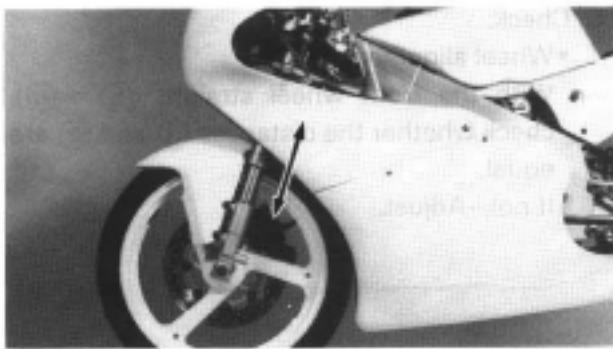

FRONT FORK INSPECTION

1. Inspect:
 - Front fork smooth action
Operate the front brake and stroke the front fork.
 - Unsmooth action/oil leakage → Repair or replace.

FRONT FORK TOP END ADJUSTMENT

1. Hold the machine on upright position by placing the suitable stand.
2. Remove:
 - Cowling
 - Front wheel
 - Front fender

3

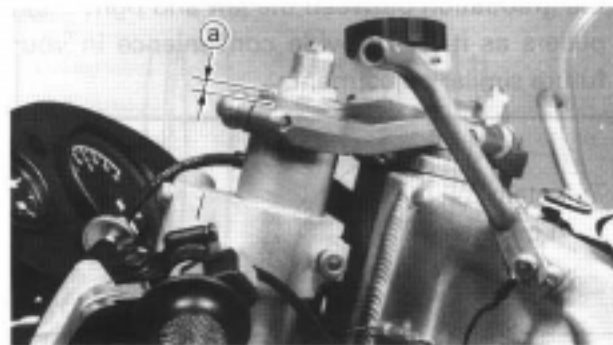
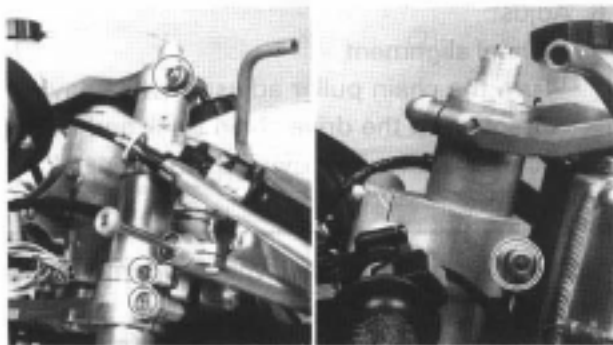

3. Adjust:
 - Front fork top end

Adjustment steps:

- Loosen the pinch bolts (handle bracket and steering damper stay).
- Loosen the pinch bolts (handle crown and under bracket).
- Adjust the front fork top end (a).



Front fork top end (a):

Standard	Extent of adjustment
15 mm (0.59 in)	Zero–20 mm (Zero–0.79 in)

CAUTION:

Never attempt to install the front fork beyond the maximum or minimum setting.

WARNING

Always adjust each front fork to the same setting. Uneven adjustment can cause poor handling and loss of stability.

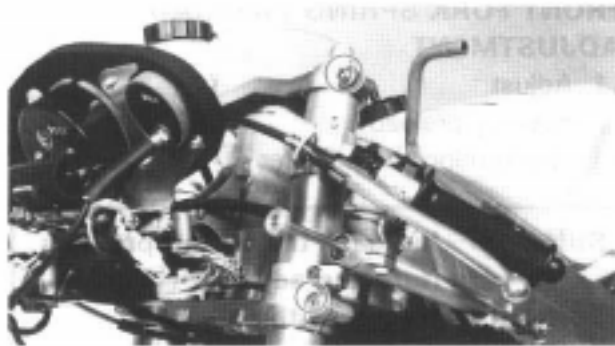

- Tighten the pinch bolts (handle crown and under bracket).



Pinch bolt (handle crown):
15 Nm (1.5 m•kg, 11 ft•lb)
Pinch bolt (under bracket):
21 Nm (2.1 m•kg, 15 ft•lb)

CAUTION:

Tighten the under bracket to specified torque. If torqued too much, it may cause the front fork to malfunction.

- Adjust the handlebar position (b) and steering damper stay position (c).



Handlebar position (b):
20 mm (0.79 in)
Steering damper stay position (c):
Zero mm (Zero in)

- Tighten the pinch bolts (handle bracket and steering damper stay).



Pinch bolt (handle bracket):
15 Nm (1.5 m•kg, 11 ft•lb)
Pinch bolt (steering damper stay):
7 Nm (0.7 m•kg, 5.1 ft•lb)

CAUTION:

Tighten the pinch bolts to specified torque. If torqued too much, it may cause the front fork to malfunction.

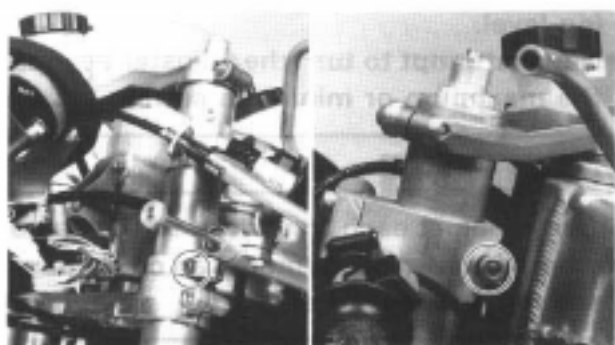

4. Check:

- Steering smooth action
Turn the handlebar to make sure no parts are being contacted with others.
Contact→Repair.

5. Install:

- Front fender
- Front wheel
- Cowling

3

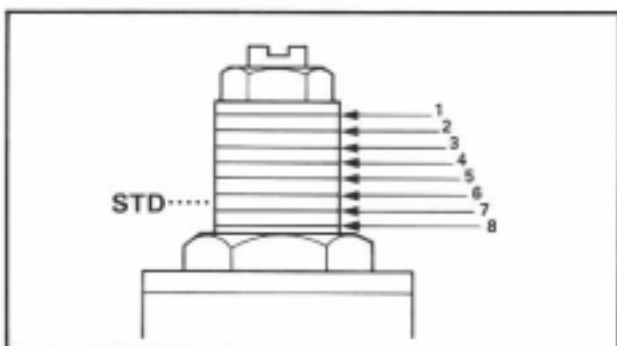
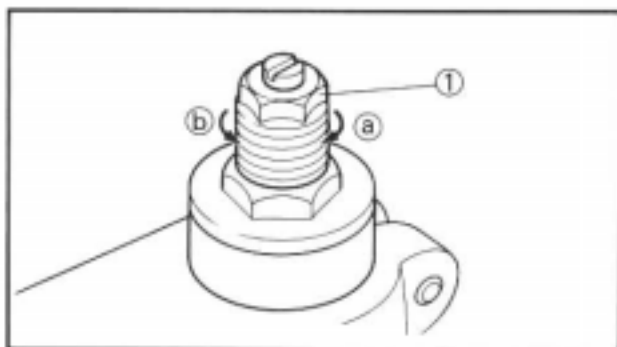

3

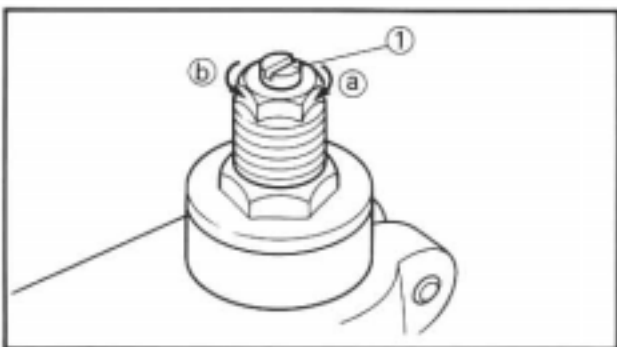

FRONT FORK SPRING PRELOAD ADJUSTMENT

1. Adjust
- Spring preload
By turning the adjuster ①.

Stiffer (a) → Increase the spring preload. (turn the adjuster ① in.)
Softer (b) → Decrease the spring preload. (turn the adjuster ① out.)



Spring preload:

Standard position	Extent of adjustment
6.5	1~8.5

CAUTION:

- Grooves are provided to show the adjusting level.
- Never attempt to turn the adjuster beyond the maximum or minimum setting.

WARNING

Always adjust each front fork to the same setting. Uneven adjustment can cause poor handling and loss of stability.

FRONT FORK REBOUND DAMPING FORCE ADJUSTMENT

1. Adjust:
- Rebound damping force
By turning the adjuster ①

Stiffer (a) → Increase the rebound damping force. (turn the adjuster ① in.)
Softer (b) → Decrease the rebound damping force. (turn the adjuster ① out.)



Extent of Adjustment:

Maximum	Minimum
Fully turned in position	12 clicks out (from maximum position)



•STANDARD POSITION:

This is the position which is back by the specific number of clicks from the fully turned-in position.



Standard position:
7 Clicks out

CAUTION:

Do not force the adjuster past the minimum or maximum extent of adjustment. The adjuster may be damaged.

WARNING

Always adjust each front fork to the same setting. Uneven adjustment can cause poor handling and loss of stability.

3

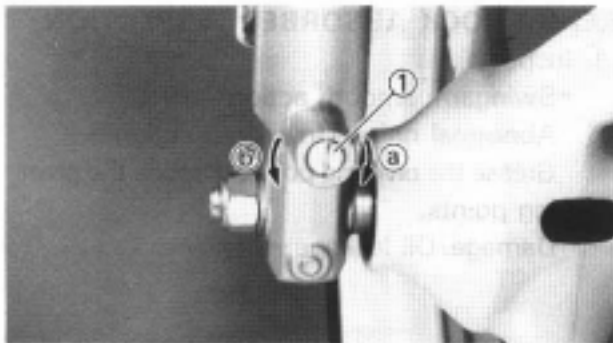

FRONT FORK COMPRESSION DAMPING FORCE ADJUSTMENT

1. Adjust:

- Compression damping force
By turning the adjuster ①.

Stiffer ② → Increase the compression damping force. (turn the adjuster ① in.)

Softer ③ → Decrease the compression damping force. (turn the adjuster ① out.)



 Extent of adjustment:	
Maximum	Minimum
Fully turned in position	10 clicks out (from maximum position)

•STANDARD POSITION:

This is the position which is back by the specific number of clicks from the fully turned-in position.

 Standard position: 7 Clicks out
--

CAUTION:

Do not force the adjuster past the minimum or maximum extent of adjustment. The adjuster may be damaged.

⚠ WARNING

Always adjust each front fork to the same setting. Uneven adjustment can cause poor handling and loss of stability.

3

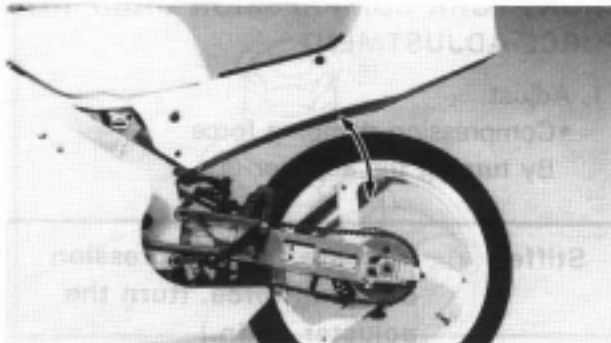

REAR SHOCK ABSORBER INSPECTION

1. Inspect:

- Swingarm smooth action
Abnormal noise/Unsmooth action → Grease the pivoting points or repair the pivoting points.
- Damage/Oil leakage → Replace.



SEAT HEIGHT ADJUSTMENT

1. Remove:
 - Fuel tank

2. Adjust:
 - Seat height

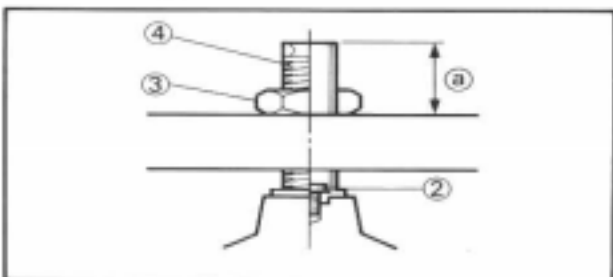

Seat height adjustment steps:

- Remove the cap ①.
- Loosen the lock bolt ② and locknut ③.
- Turn the adjuster ④ in or out.

Seat height ④:	
Standard length	Extent of adjustment
29 mm (1.14 in)	17 – 35 mm (0.67 – 1.38 in)

CAUTION:

Never attempt to turn the adjuster beyond the maximum or minimum length.

- Tighten the lock bolt and locknut.

Lock bolt:
30 Nm (3.0 m•kg, 22 ft•lb)

Locknut:
38 Nm (3.8 m•kg, 27 ft•lb)

- Install the cap.

3

3. Install:
 - Fuel tank

REAR SHOCK ABSORBER SPRING PRELOAD ADJUSTMENT

1. Hold the machine on upright position by placing the suitable stand.
2. Loosen:
 - Locknut ①



REAR SHOCK ABSORBER REBOUND DAMPING FORCE ADJUSTMENT

**INSP
ADJ**



3. Adjust:
- Spring preload
By turning the adjuster ②.

Stiffer → Increase the spring preload.
(turn the adjuster ② in.)
Softer → Decrease the spring preload.
(turn the adjuster ② out.)

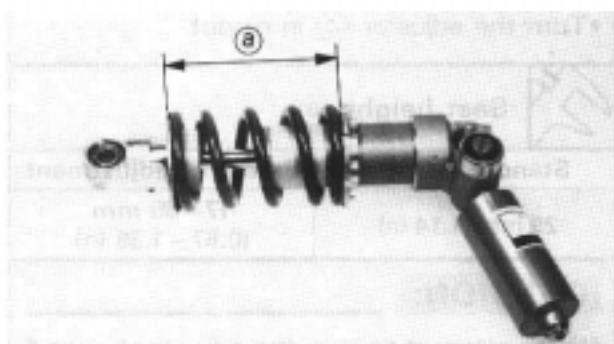

3

Spring length (installed):	
Standard length ②	Extent of adjustment
120 mm (4.72 in)	110–123 mm (4.33–4.84 in)

NOTE:
The length of the spring (installed) changes 1.5 mm (0.06 in) per turn of the adjuster.

CAUTION:
Never attempt to turn the adjuster beyond the maximum or minimum setting.

4. Tighten
- Locknut

	Locknut: 40 Nm (4.0 m•kg, 29 ft•lb)
--	---

REAR SHOCK ABSORBER REBOUND DAMPING FORCE ADJUSTMENT

1. Adjust:
- Rebound damping force
By turning the adjuster ①.

Stiffer ① → Increase the rebound damping force. (turn the adjuster ① in.)
Softer ② → Decrease the rebound damping force. (turn the adjuster ① out.)

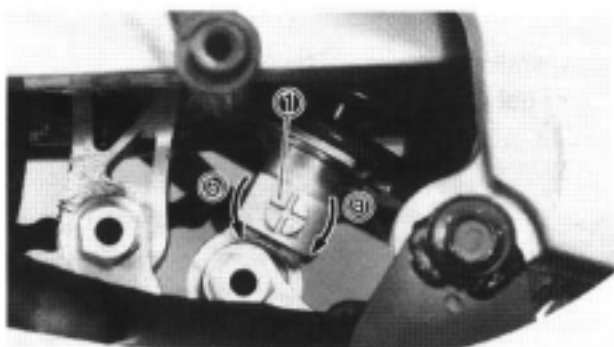

REAR SHOCK ABSORBER COMPRESSION DAMPING FORCE ADJUSTMENT

**INSP
ADJ**



 Extent of adjustment:	
Maximum	Minimum
Fully turned in position	36 clicks out (from maximum position)

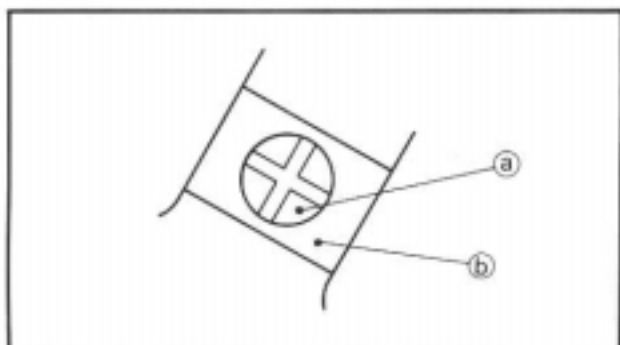

•STANDARD POSITION:

This is the position which is back by the specific number of clicks from the fully turned-in position. (Which align the punch mark **a** on the adjuster with the punch mark **b** on the bracket.)

 Standard position: About 17 clicks out

CAUTION:

Do not turn out (in) the adjuster from the damping force minimum (maximum) setting.

3

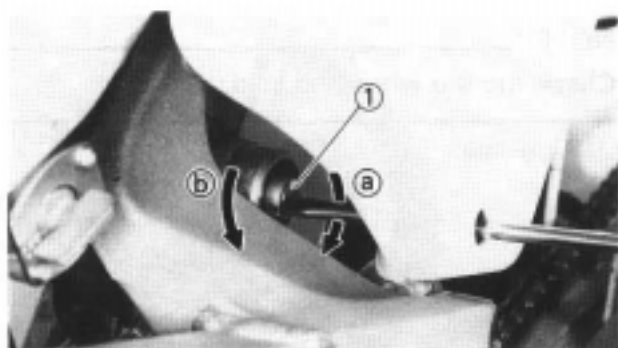

REAR SHOCK ABSORBER COMPRESSION DAMPING FORCE ADJUSTMENT

1. Adjust:

- Compression damping force
By turning the adjuster **1**.

Stiffer **a** → Increase the compression damping force. (turn the adjuster **1** in.)
Softer **b** → Decrease the compression damping force. (turn the adjuster **1** out.)

 Extent of adjustment:	
Maximum	Minimum
20 clicks in (from minimum position)	Fully turned out position

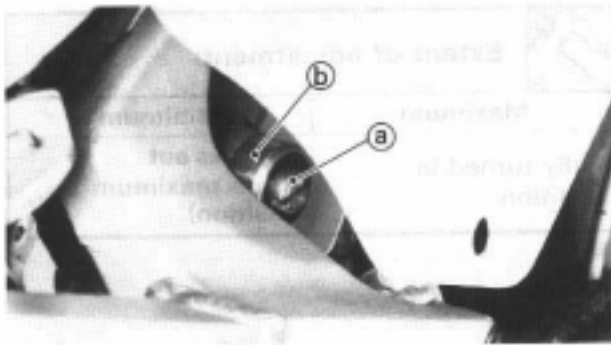

•STANDARD POSITION:

This is the position which is back by the specific number of clicks from the fully turned-out position (Which align the punch mark **a** on the adjuster with the punch mark **b** on the bracket.)



Standard position:
About 10 clicks in

CAUTION:

Do not turn out (in) the adjuster from the damping force minimum (maximum) setting.

3

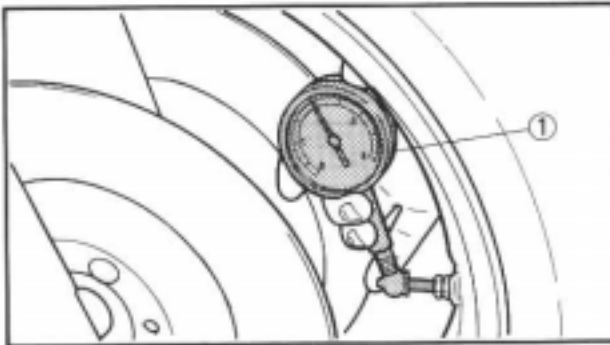

TIRE PRESSURE CHECK

1. Measure:

- Tire pressure
- Out of specification → Adjust.



Standard tire pressure:

Front	Rear
190 kPa (1.9 kg/cm ² , 27 psi)	190 kPa (1.9 kg/cm ² , 27 psi)

NOTE:

Check the tire while it is cold.

① Air gauge

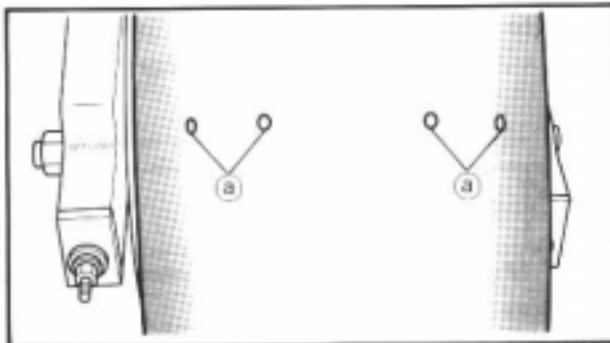

TIRE INSPECTION

1. Inspect:

- Tire surfaces
- Wear/ Damage → Replace.



Minimum tire tread depth **a**:
2 mm (0.08 in)

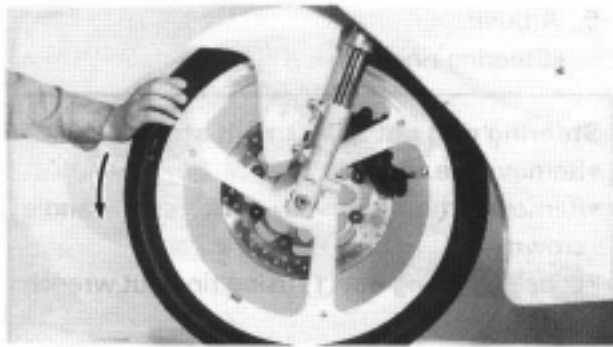

WHEEL INSPECTION

1. Inspect:
 - Wheel runout
Elevate the wheel and turn it.
Abnormal runout→Replace.

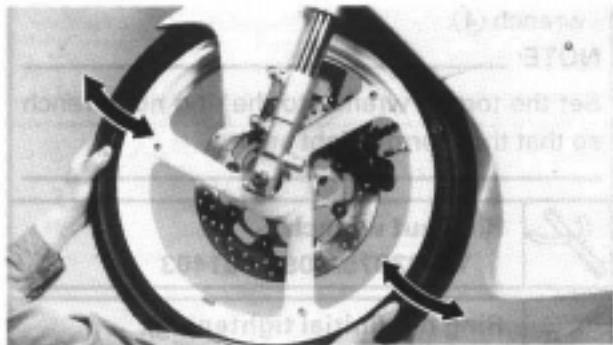

2. Inspect:
 - Bearing free play
Exist play→Replace.

**STEERING HEAD INSPECTION AND
ADJUSTMENT**

3

1. Remove the steering damper at front fork side.
2. Elevate the front wheel by placing a suitable stand.

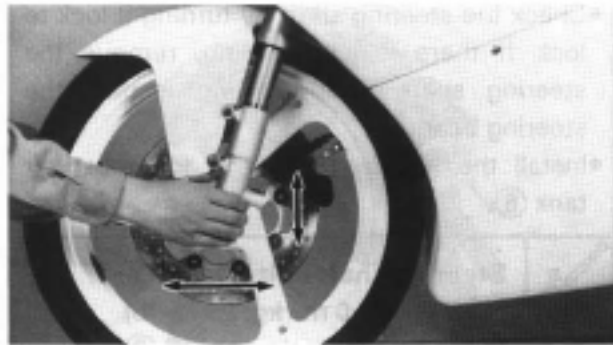

3. Check:
 - Steering stem
Grasp the bottom of the forks and gently rock the fork assembly back and forth.
Free play→Adjust steering head.

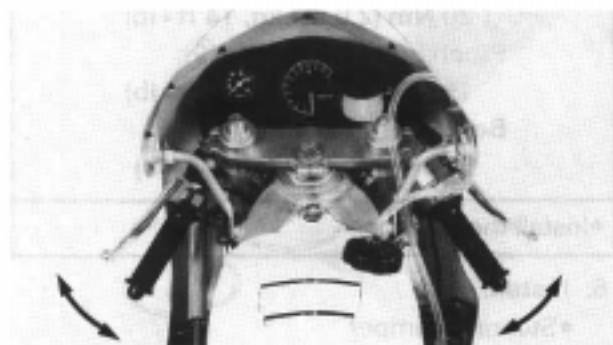

4. Check:
 - Steering smooth action
Turn the handlebar lock to lock.
Unsmooth action→Adjust steering ring nut.



3



5. Adjust:
- Steering ring nut

- Steering ring nut adjustment steps:**
- Remove the cowling.
 - Remove the reservoir tank and handle crown.
 - Loosen the ring nut ① using ring nut wrench ②.
 - Tighten the ring nut ③ using ring nut wrench ④.

NOTE: _____
Set the torque wrench to the ring nut wrench so that they form a right angle.

 **Ring nut wrench:**
YU-33975/90890-01403

 **Ring nut (initial tightening):**
46 Nm (4.6 m • kg, 33 ft • lb)

- Loosen the ring nut one turn.
- Retighten the ring nut using the ring nut wrench.

⚠ WARNING _____
Avoid over-tightening.

 **Ring nut (final tightening):**
1 Nm (0.1 m • kg, 0.7 ft • lb)

- Check the steering shaft by turning it lock to lock. If there is any binding, remove the steering shaft assembly and inspect the steering bearings.
- Install the handle crown ⑤ and reservoir tank ⑥.

 **Steering shaft bolt ⑦:**
40 Nm (4.0 m • kg, 29 ft • lb)
Pinch bolt (steering shaft) ⑧:
20 Nm (2.0 m • kg, 14 ft • lb)
Pinch bolt (front fork) ⑨:
15 Nm (1.5 m • kg, 11 ft • lb)
Bolt (reservoir tank) ⑩:
5 Nm (0.5 m • kg, 3.6 ft • lb)

- Install the cowling.

6. Install:
- Steering damper



STEERING DAMPER ADJUSTMENT

1. Adjust:
 - Damping force
By turning the adjuster ①.

Stiffer (a) → Increase the compression damping force. (turn the adjuster ① in.)

Softer (b) → Decrease the compression damping force. (turn the adjuster ① out.)



Extent of adjustment:

Maximum	Minimum
Fully turned in position	10 clicks out (from maximum position)

• **STANDARD POSITION**

This is the position which is back by the specific number of clicks from the fully turned-in position.



Standard position:
About 5 clicks out

CAUTION:

Do not turn out (in) the adjuster from the damping force minimum (maximum) setting.

WIRES, CABLES

1. Inspect:
 - Smooth movement for steering handle
By turning the handlebar lock to lock.
If any caught/rubbed → Repair/Replace.

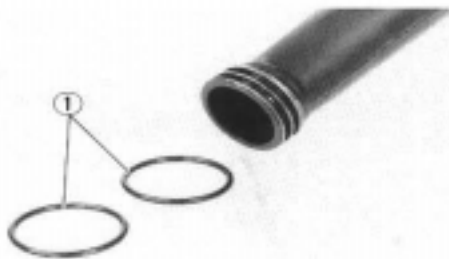

MUFFLER INSPECTION

1. Inspect:
 - O-ring ①
Damage → Replace.

3

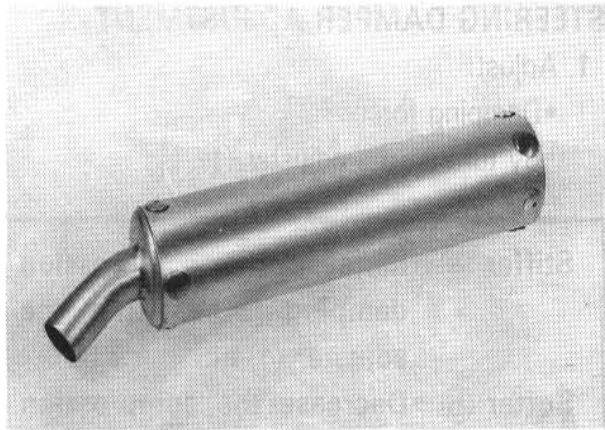

SILENCER INSPECTION

1. Inspect:
 - Silencer
Inside of silencer loose → Repair.

Silencer repair steps:

- Drill the silencer for rivetting.
- Rivet the silencer using the rivet.

NOTE: _____
Rivet the silencer in a different area than previously riveted.

3

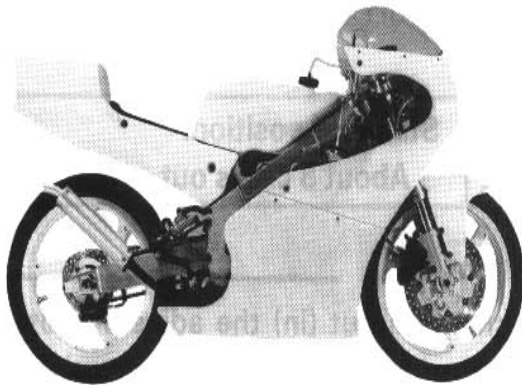

COWLING INSTALLATION INSPECTION

1. Inspect:
 - Cowling
Loosen → Tighten.
Stroke the front fork to make sure no parts are being contacted with others.
Contact → Repair or replace.
 - Screen
Scratches/fogging → Clean or replace.



LUBRICATION

To ensure smooth operation of all components lubricate your machine during setup, after break-in, and after every race.

- ① All control cable
- ② Brake and clutch lever pivots
- ③ Throttle-to-handlebar contact
- ④ Drive chain
- ⑤ Throttle guide and cable end
- ⑥ Clutch cable end

- A** Use Yamaha cable lube or equivalent on these areas.
- B** Use SAE 10W30 motor oil or suitable chain lubricants.
- C** Lubricate the following areas with highquality, lightweight lithium-soap base grease.

CAUTION:

Wipe off any excess grease, and avoid getting grease on the brake discs.

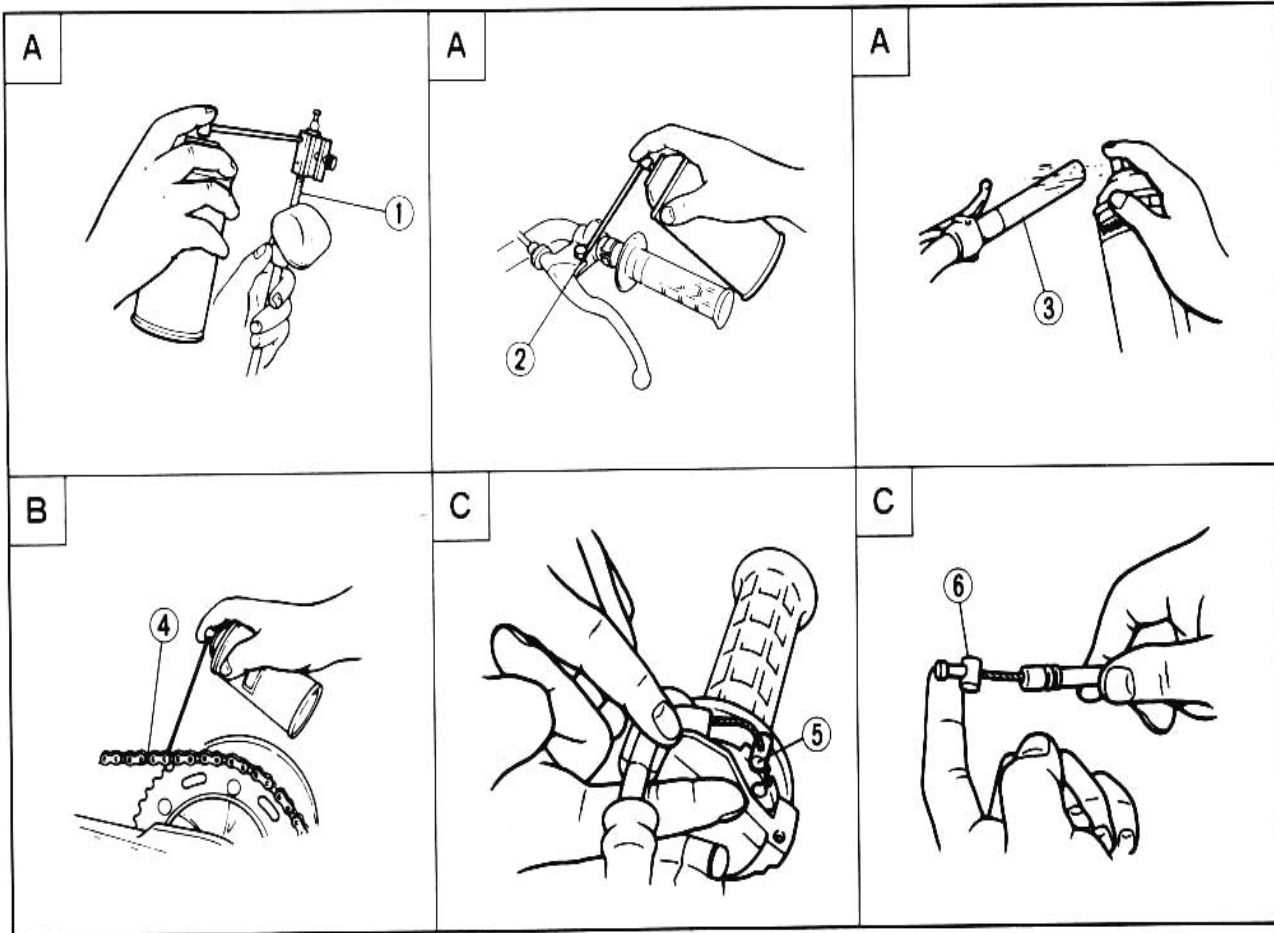

3

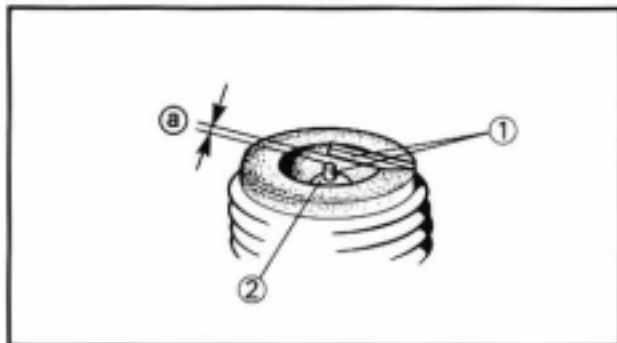

SPARK PLUG INSPECTION

1. Remove:
 - Spark plug
2. Inspect:
 - Electrode ①
Wear/Damage → Replace.
 - Insulator color ②
Normal condition is a medium to light tan color.
Distinctly different color → Check the engine condition.

NOTE: _____

When the engine runs for many hours at low speeds, the spark plug insulator will become sooty, even if the engine and carburetor are in good operating condition.

3

3. Measure:
 - Plug gap ③
Use a wire gauge or thickness gauge.
Out of specification → Regap.

	Spark plug gap: 0.5 ~ 0.6 mm (0.020 ~ 0.024 in)
---	---

Standard spark plug: R6385-105P (NGK)

4. Clean the plug with a spark plug cleaner if necessary.
5. Tighten:
 - Spark plug

	Spark plug: 19 Nm (1.9 m·kg, 13 ft·lb)
--	--

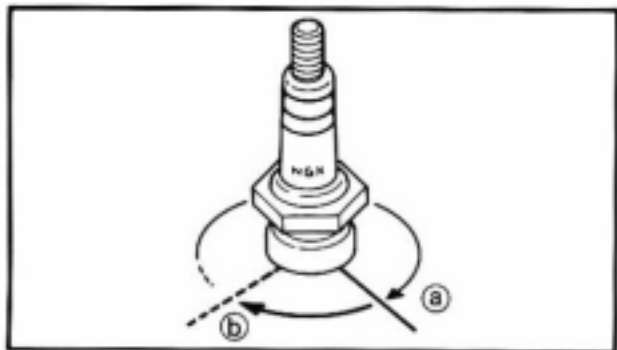

NOTE: _____

- Before installing a spark plug, clean the gasket surface and plug surface.
- Finger-tighten ③ the spark plug before torquing to specification ④.

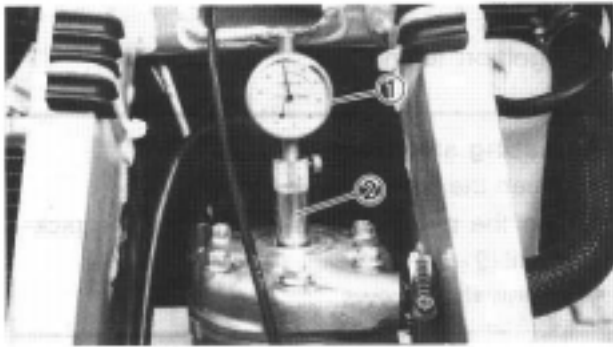

IGNITION TIMING CHECK

1. Remove:
 - Cowling
 - Fuel tank
 - Spark plug
2. Attach:
 - Dial gauge ①
 - Dial gauge stand ②

	Dial gauge:
	YU-03097/90890-01252
	Stand:
	YU-01256

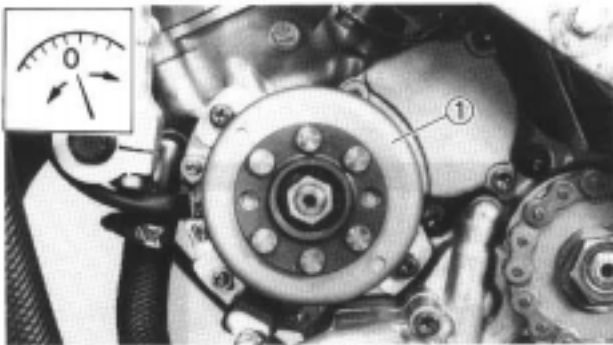

3. Rotate the magneto rotor ① until the piston reaches top dead center (TDC). When this happens, the needle on the dial gauge will stop and reverse directions even though the rotor is being turned in the same direction.
4. Set the dial gauge to zero at TDC.
5. From TDC, rotate the rotor clockwise until the dial gauge indicates that the piston is at a specified distance from TDC.

	Ignition timing:
	2.1 mm (0.083 in)



6. Check:
 - Ignition timing
 Punch mark ① on rotor should be aligned with punch mark ② on pick-up coil.
 Not aligned → Adjust.

3

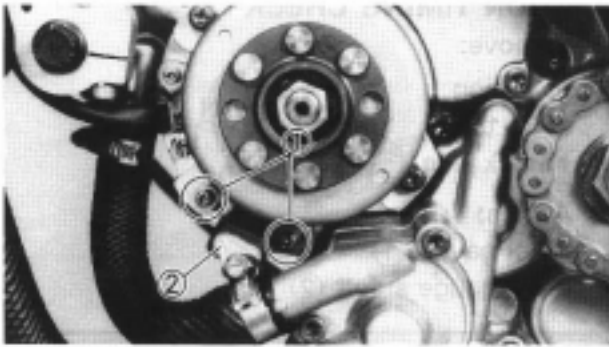

7. Adjust:
- Ignition timing

Adjusting steps:

- Loosen the screws (pick-up coil) ①.
- Align the punch marks by moving the pick-up coil ②.
- Tighten the screws.



Screw (pick-up coil):
2 Nm (0.2 m•kg, 1.4 ft•lb)

3



**COWLING, SEAT, FUEL TANK, EXHAUST PIPE AND SILENCER
PREPARATION FOR REMOVAL**



- * Turn the fuel cock to "OFF"
- * Disconnect the fuel hose.
- * Disconnect the fuel tank breather hose.

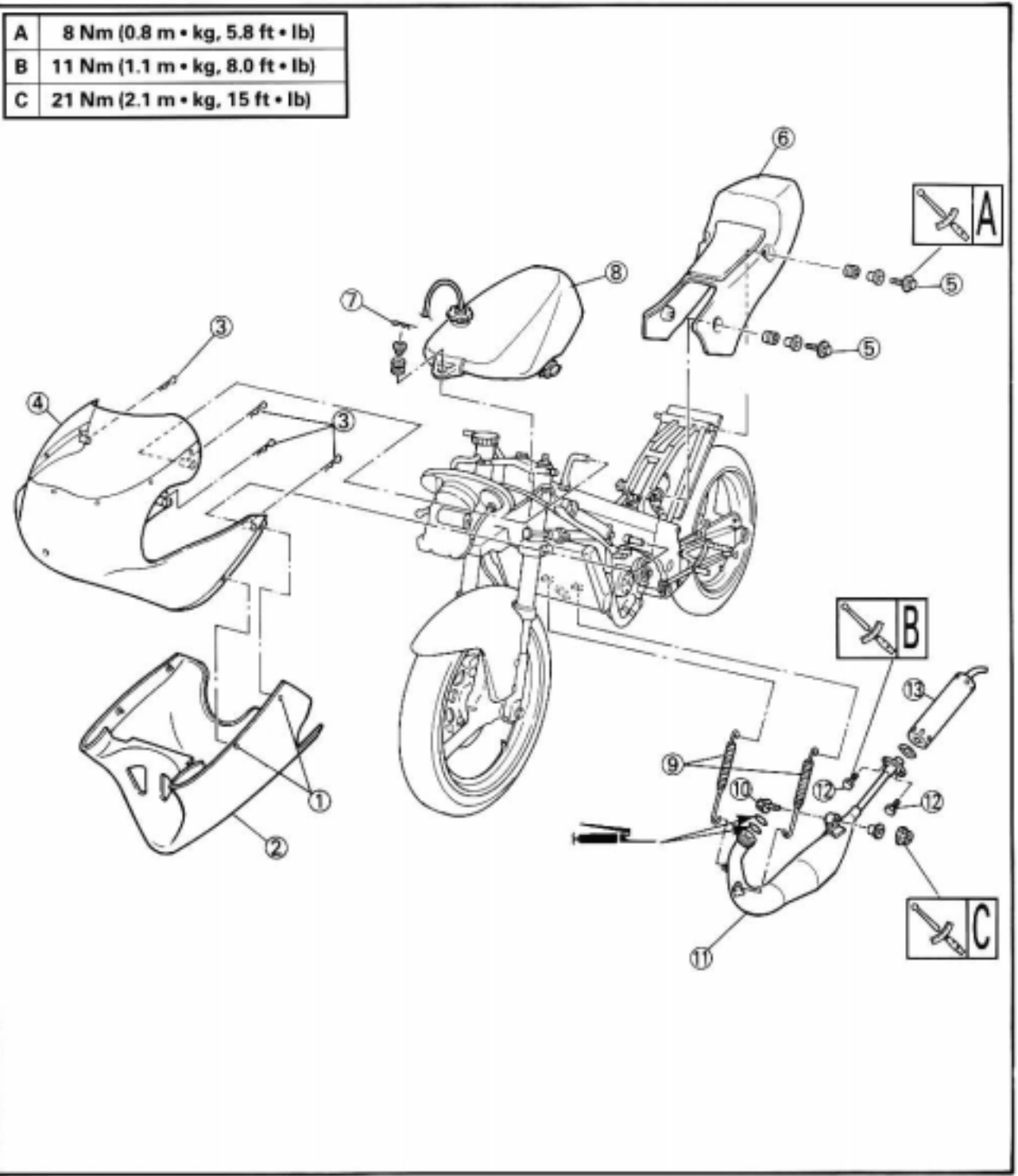

4

COWLING, SEAT, FUEL TANK, EXHAUST PIPE AND SILENCER

ENG



Extent of removal: ① Cowling removal ② Seat removal ③ Fuel tank removal
④ Exhaust pipe and silencer removal

Extent of removal	Order	Part name	Q'ty	Remarks
	1	Quick fastener	4	
	2	Lower cowl	1	
	3	Clip (upper cowl)	4	
	4	Upper cowl	1	
	5	Bolt (seat)	4	
	6	Seat	1	
	7	Clip (fuel tank)	1	
	8	Fuel tank	1	
	9	Tension spring	2	
	10	Bolt (exhaust pipe)	1	
	11	Exhaust pipe	1	
	12	Bolt (silencer)	2	
	13	Silencer	1	

4



RADIATOR PREPARATION FOR REMOVAL



- * Remove the cowling.
- * Remove the fuel tank.
- * Drain the cooling water.
- * Remove the steering damper.

COOLING WATER CAPACITY:
0.89 L (0.78 Imp qt, 0.94 US qt)

**RADIATOR CAP OPENING
PRESSURE:**
95~125kPa
(0.95~1.25 kg/cm², 13.5~17.8 psi)

A 2 Nm (0.2 m·kg, 1.4 ft·lb)

B 7 Nm (0.7 m·kg, 5.1 ft·lb)

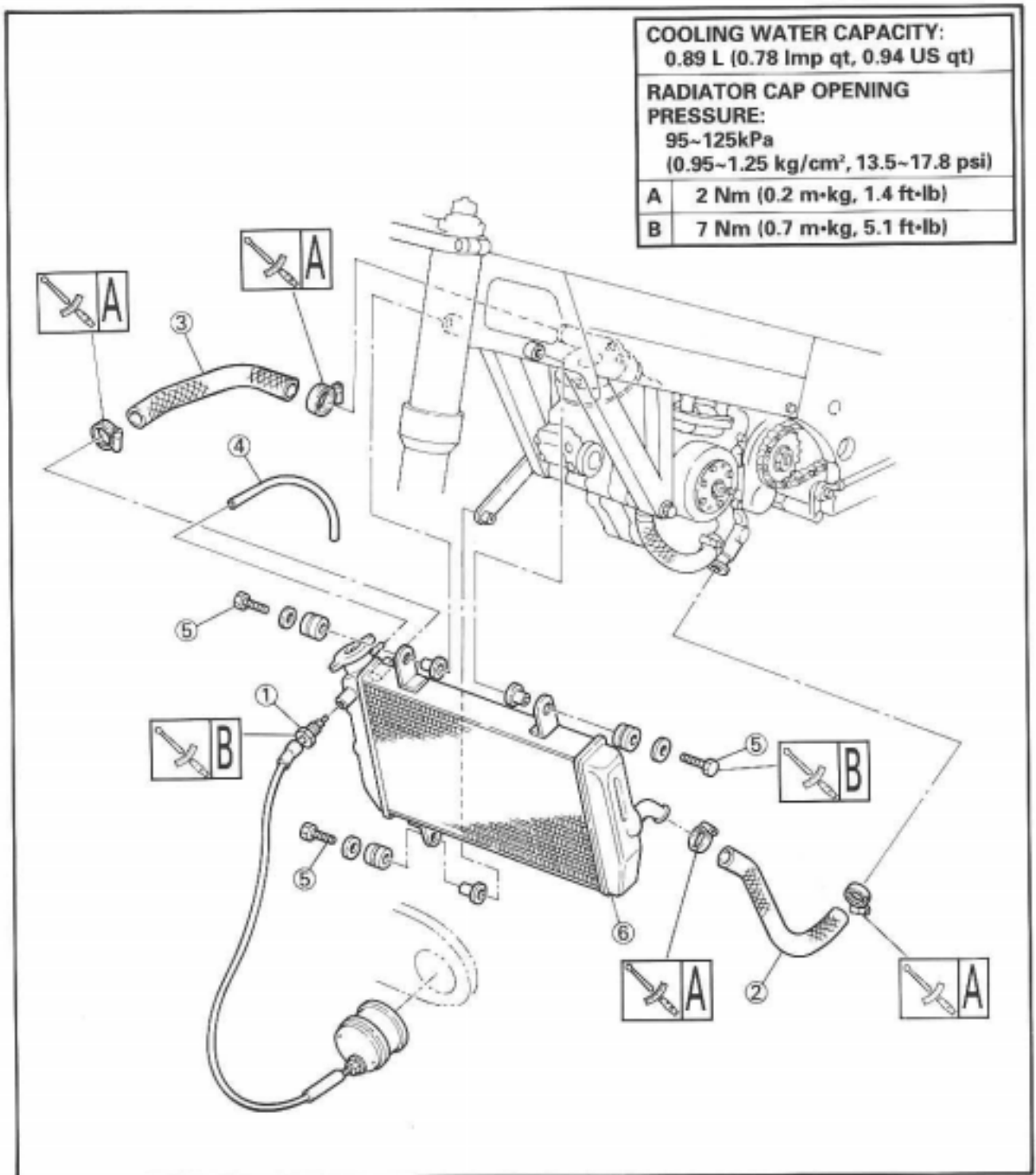



NOTE ON REMOVAL AND REASSEMBLY

- Before servicing, clean parts, and take care so that the foreign material does not enter the crankcase.
- For reassembly the removed parts should be cleaned with solvent.

Extent of removal: ① Radiator removal

Extent of removal	Order	Part name	Q'ty	Remarks
	1	Thermo sensor	1	Refer to "REMOVAL POINTS".
	2	Radiator hose 2	1	
	3	Radiator hose 4	1	
	4	Radiator breather hose	1	
	5	Bolt (radiator)	3	
	6	Radiator	1	

REMOVAL POINTS

⚠ WARNING

Do not remove the radiator cap when the engine and radiator are hot. Scalding hot fluid and steam may be blown out under pressure, which could cause serious injury.

When the engine has cooled, open the radiator cap by the following procedure:

Remove the radiator cover by removing the screw. Place a thick rag, like a towel, over the radiator cap, slowly rotate the cap counterclockwise to the detent. This procedure allows any residual pressure to escape.

When the hissing sound has stopped, press down on the cap while turning counterclockwise and remove it.

4

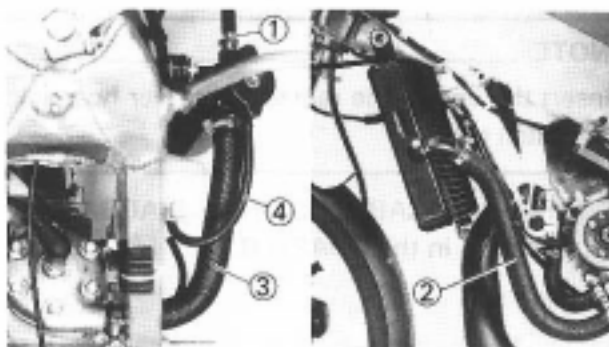

Radiator

1. Remove:

- Thermo sensor ①
- Radiator hose 2 ②
- Radiator hose 4 ③
- Radiator breather hose ④

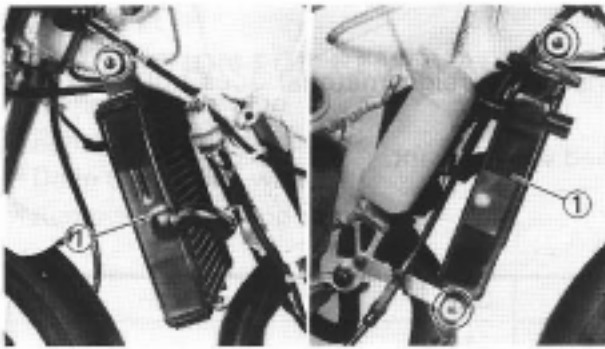

2. Remove:
- Radiator ①

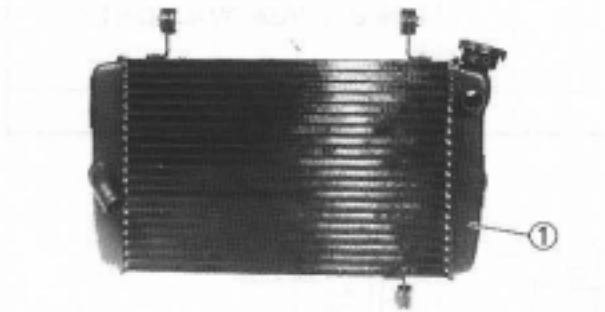

INSPECTION

Radiator

1. Inspect:
- Radiator core ①
- Obstruction → Blow out with compressed air through rear of the radiator.
- Bent fin → Repair/replace.

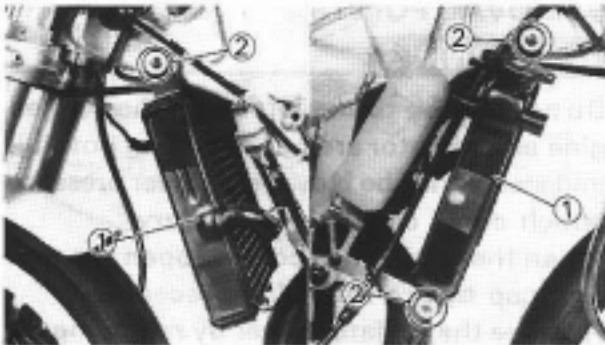

ASSEMBLY AND INSTALLATION

Radiator

1. Install:
- Radiator ①
 - Bolt (radiator) ②



Bolt (radiator):
7 Nm (0.7 m•kg, 5.1 ft•lb)

2. Install:
- Radiator hose 2 ①
 - Radiator hose 4 ②
 - Radiator breather hose ③
 - Thermo sensor ④



Radiator hose clamp:
2 Nm (0.2 m•kg, 1.4 ft•lb)

Thermo sensor:
7 Nm (0.7 m•kg, 5.1 ft•lb)

NOTE:

Insert the end of the radiator breather hose into the catch tank.

Refer to "CABLE ROUTING DIAGRAM" section in the CHAPTER 2.

4

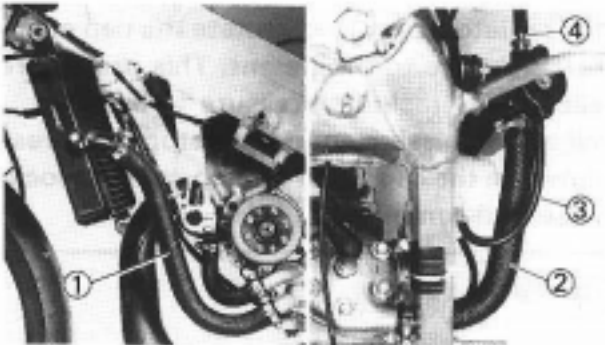



**CARBURETOR AND REED VALVE
PREPARATION FOR REMOVAL**



- * Turn the fuel cock to "OFF".
- * Disconnect the fuel hose.

- * Remove the following parts.
 - Cowling
 - Fuel tank

SPECIFICATIONS	
MAIN JET (M.J.)	#560
JET NEEDLE (J.N.)	6DFI2-61-3
PILOT JET (P.J.)	#20
PILOT AIR SCREW (P.A.S.)	1-1/2
NEEDLE JET (N.J.)	R-7
POWER JET (P.W.J.)	#60
FLOAT LEVEL HEIGHT	15.2~17.2 mm (0.60~0.68 in)

A	1 Nm (0.1 m·kg, 0.7 ft·lb)
B	11 Nm (1.1 m·kg, 8.0 ft·lb)
C	2 Nm (0.2 m·kg, 1.4 ft·lb)

4

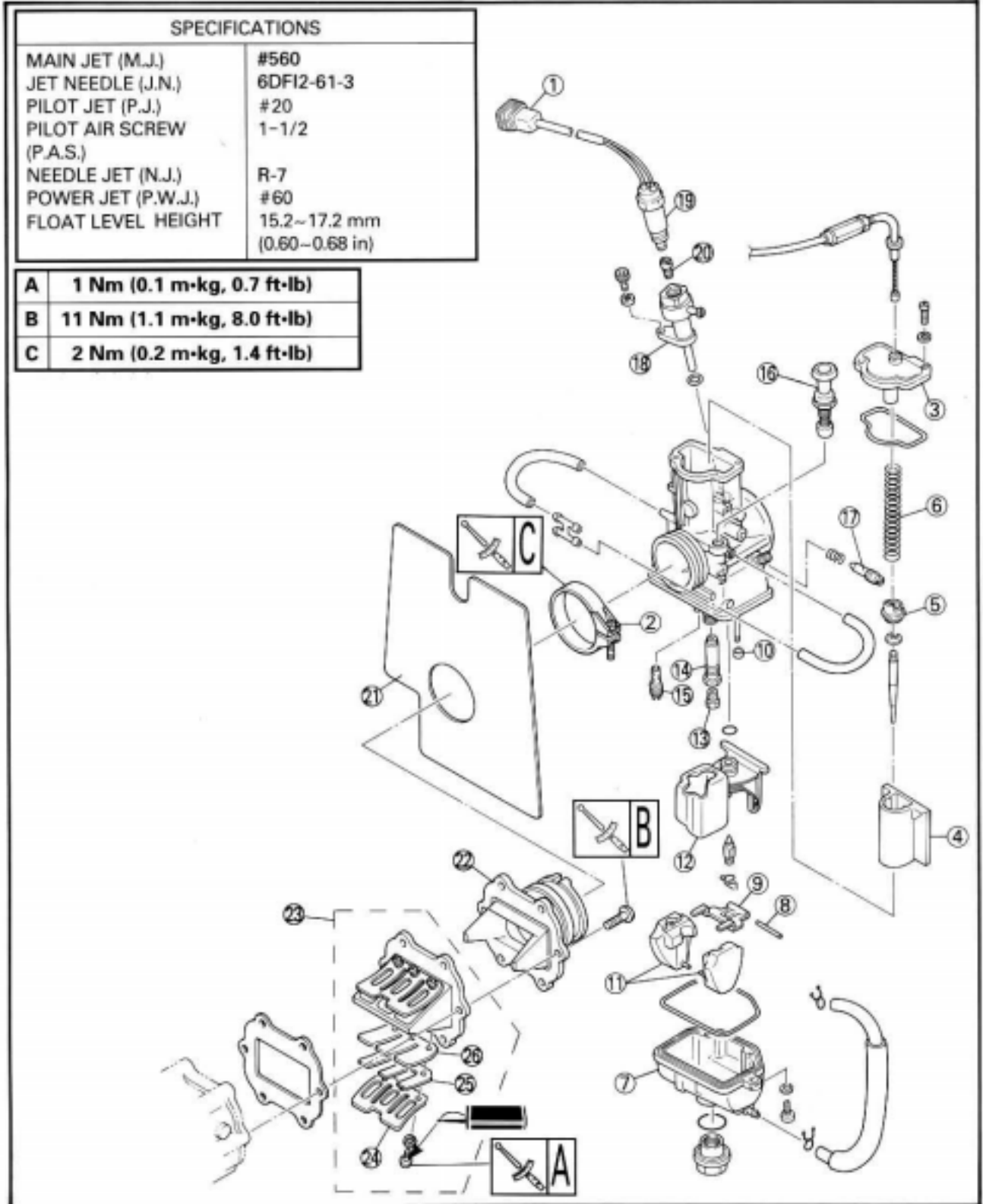



NOTE ON REMOVAL AND REASSEMBLY

- Before servicing, clean the machine and take care so that foreign material does not enter the engine.
- Remove any gasket adhered to the contacting surfaces.
- Before inspection, the removed parts should be cleaned and blow out all passages and jets with compressed air.
- After removing the carburetor, cover the carburetor joint not to foreign material.

Extent of removal: ① Carburetor removal ② Carburetor disassembly
 ③ Reed valve removal and disassembly

Extent of removal	Order	Part name	Q'ty	Remarks
	1	Solenoid valve lead	1	Disconnect the solenoid valve lead.
	2	Clamp (carburetor joint)	1	Loosen the screw (carburetor joint).
	3	Mixing chamber top	1	Refer to "REMOVAL POINTS".
	4	Throttle valve	1	
	5	Ring	1	
	6	Spring (throttle valve)	1	
	7	Float chamber	1	
	8	Pin (float)	1	
	9	Float arm	1	
	10	Cap	2	
	11	Float	2	
	12	Needle jet cover	1	
	13	Main jet	1	
	14	Main nozzle	1	
	15	Pilot jet	1	
	16	Starter plunger	1	
	17	Pilot air screw	1	
	18	Holder	1	
	19	Solenoid valve	1	
	20	Power jet	1	
	21	Carburetor cover	1	
	22	Carburetor joint	1	
	23	Reed valve assembly	1	
	24	Stopper (reed valve)	2	
	25	Reed valve 2	2	
	26	Reed valve 1	2	

4

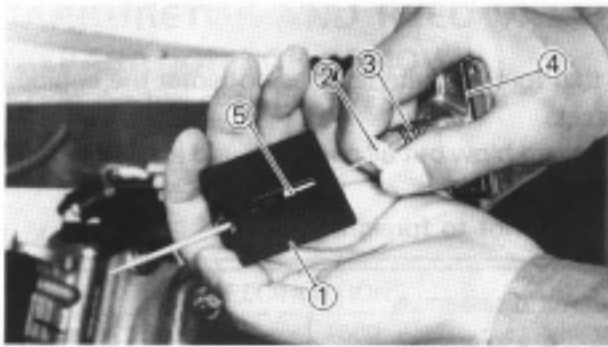

REMOVAL POINTS

Throttle valve

1. Remove:
 - Throttle valve ①
 - Ring ②
 - Spring (throttle valve) ③
 - Mixing chamber top ④
 - Throttle cable ⑤

CAUTION:

Do not use the '94 model or earlier throttle valve for the '95 model carburetor. (The '95 throttle valve is provided with a punch mark @ for identification.)

NOTE:

While compression the spring (throttle valve), disconnect the throttle cable.

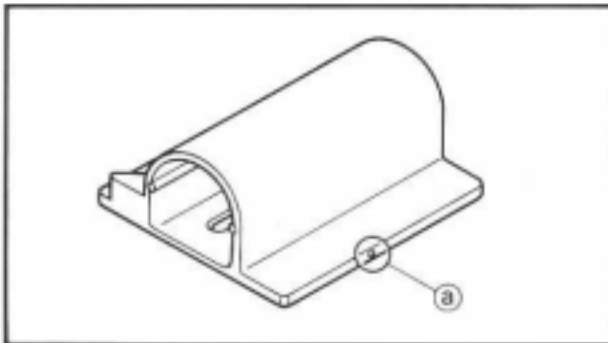

Float chamber

1. Remove:
 - Screw ①
 - Drain plug ②
 - Float chamber ③

4

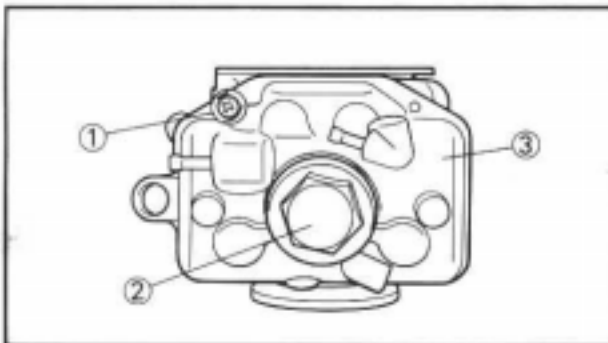

INSPECTION

Carburetor

1. Inspect:
 - Carburetor body
Contamination → Clean.

NOTE:

- Use a petroleum based solvent for cleaning. Blow out all passages and jets with compressed air.
- Never use a wire.

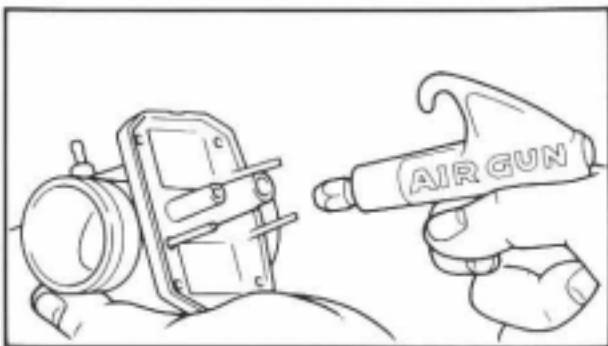

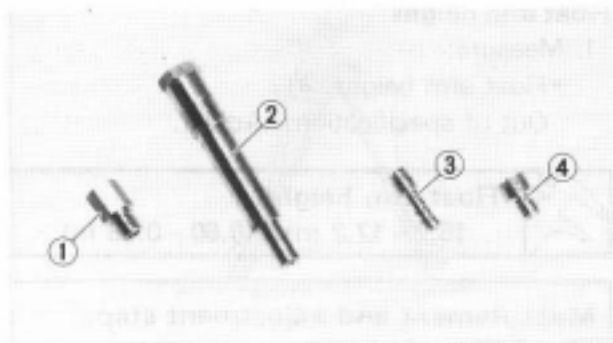

2. Inspect:

- Main jet ①
- Main nozzle ②
- Pilot jet ③
- Power jet ④

Contamination → Clean.

NOTE:

- Use a petroleum based solvent for cleaning. Blow out all passages and jets with compressed air.
- Never use a wire.

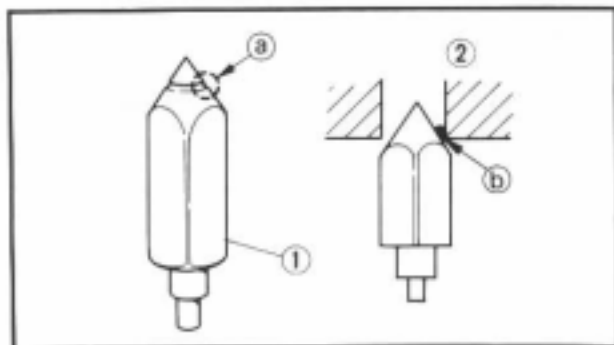

Needle valve

1. Inspect:

- Needle valve ①
 - Valve seat ②
- Grooved wear (a) → Replace.
Dust (b) → Clean.

NOTE:

Always replace the needle valve and valve seat as a set.

4

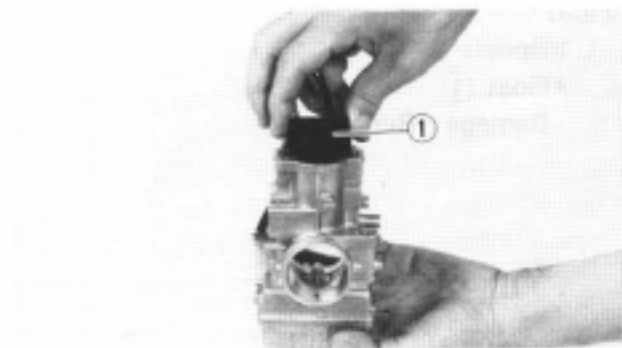

Throttle valve

1. Check:

- Free movement
- Stick → Repair or replace.
Insert the throttle valve ① into the carburetor body, and check for free movement.

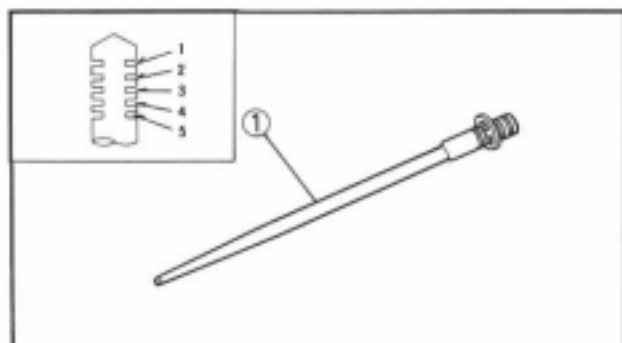

2. Inspect:

- Jet needle ①
- Bends/Wear → Replace.
• Clip position



Standard clip position:
No. 3 Groove

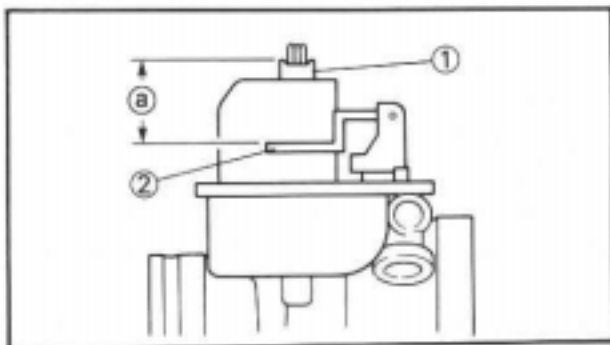

Float arm height

1. Measure:

- Float arm height (a)
- Out of specification → Adjust.



Float arm height:
15.2 – 17.2 mm (0.60 – 0.68 in)

Measurement and adjustment steps:

- Hold the carburetor in an upside down position.
- Measure the distance between the top surface of the main nozzle (1) and the top surface of the float arm (2) using vernier calipers.

NOTE:

The float arm should be resting on the needle valve, but not compressing the needle valve.

- If the float height is not within specification, inspect the valve seat and needle valve.
- If either is worn, replace them both.
- If both are fine, adjust the float height by bending the float tab (b) on the float arm.
- Recheck the float height.

4

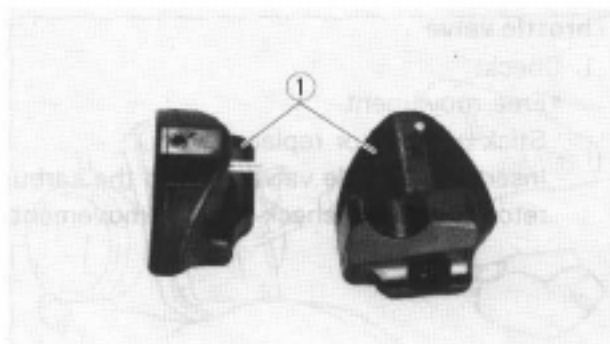
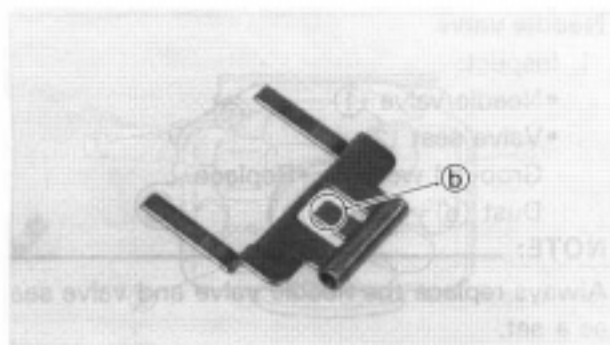

Float

1. Inspect:

- Float (1)
- Damage → Replace.

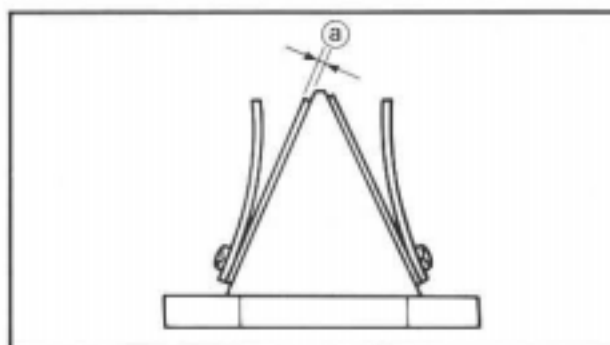

Reed valve

1. Measure:

- Reed valve bending (a)
- Out of specification → Replace.



Reed valve bending limit:
0.2 mm (0.008 in)

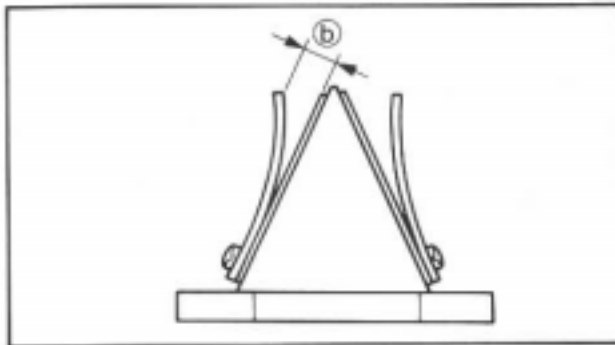

- Valve Stopper Height (b)
Out of specification → Adjust stopper/Replace valve stopper.



Valve stopper height:
10.6~11.0 mm (0.417~0.433 in)

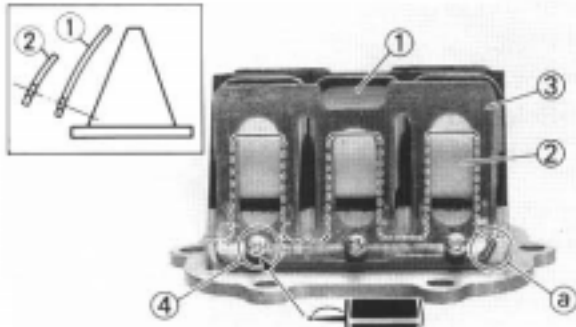

ASSEMBLY AND INSTALLATION

Reed valve

1. Install:
 - Reed valve 1 (1)
 - Reed valve 2 (2)
 - Stopper (reed valve) (3)
 - Screw (reed valve) (4)

NOTE: _____

- Install the reed valve with the reed valve bending as shown.
- Note the cut (a) in the lower corner of the reed and stopper plate.



Screw (reed valve):
1 Nm (0.1 m•kg, 0.7 ft•lb)
LOCTITE®

4

CAUTION: _____

Tighten each screw gradually to avoid warping.

2. Install:
 - Gasket (reed valve assembly) (1)
 - Reed valve assembly (2)

NOTE: _____

Always use a new gasket.

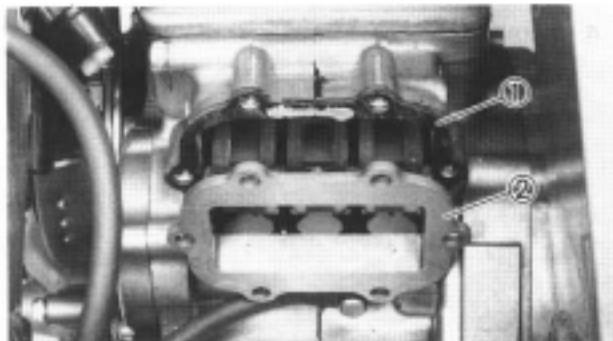

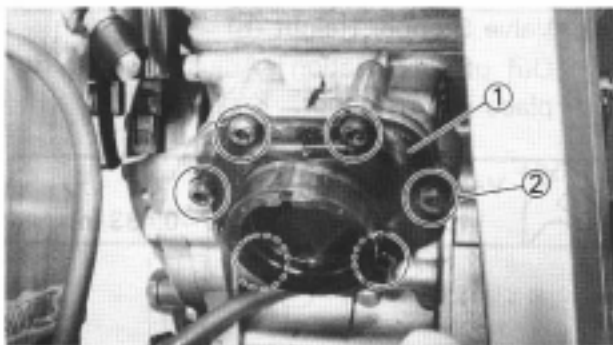

3. Install:
- Carburetor joint ①
 - Bolt (carburetor joint) ②



Bolt (carburetor joint):
11 Nm (1.1 m•kg, 8.0 ft•lb)

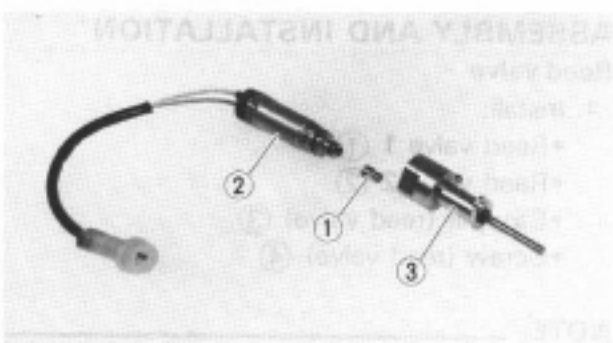

Carburetor

1. Install:
- Power jet ①
 - Solenoid valve ②
 - To holder ③.

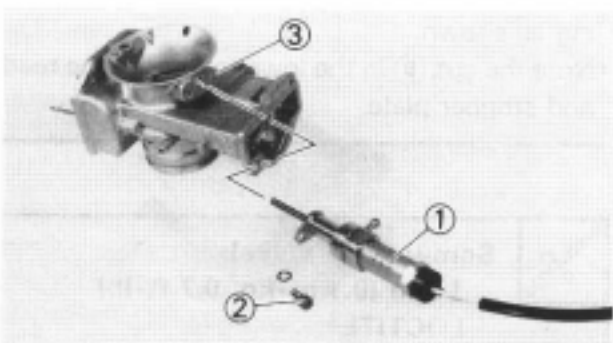

2. Install:
- Solenoid valve ①
 - Bolt (solenoid valve) ②
 - To carburetor ③.

4

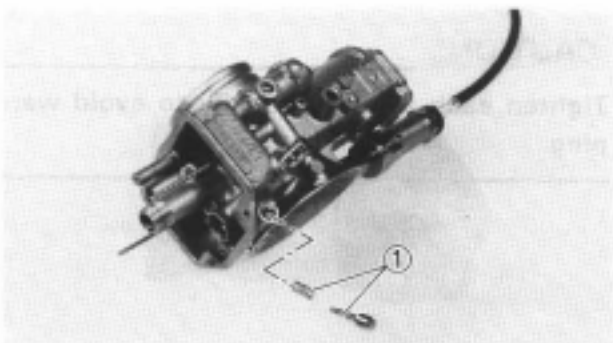

3. Install:
- Pilot air screw ①

Note the following installation points:

- Screw in the pilot air screw ① until it is lightly seated.
- Back out it by the specified number of turns.



Pilot air screw:
1-1/2 turn out



4. Install:
- Starter plunger ①

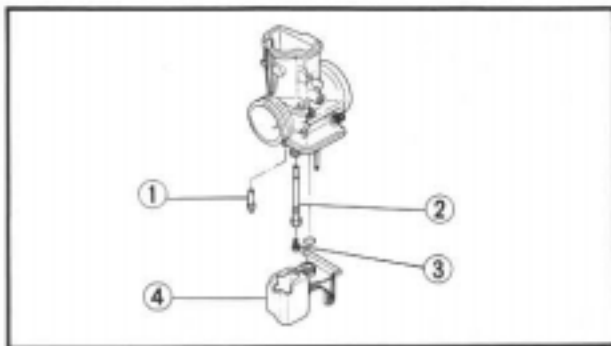

5. Install:
- Pilot jet ①
 - Main nozzle ②
 - Main jet ③
 - Needle jet cover ④

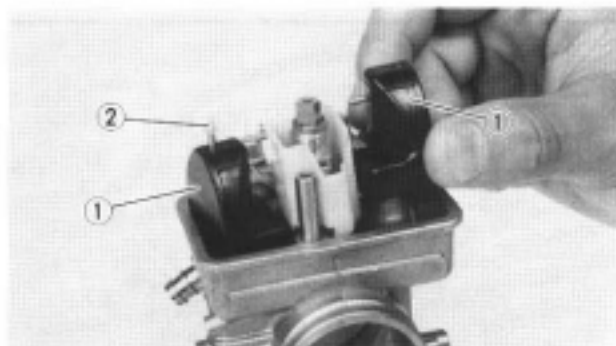

6. Install:
- Float ①
 - Cap ②

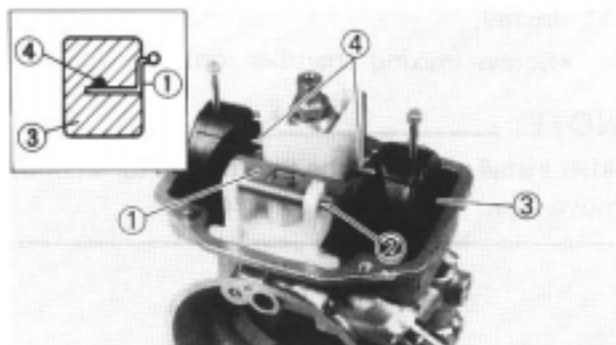

7. Install:
- Needle valve
 - Float arm ①
 - Float pin ②
- After installing the needle valve to float arm, install them to the carburetor.

NOTE:

- Make sure the float arm for smooth movement.
- Position the float arm lower than pin ④ of the float ③.

4

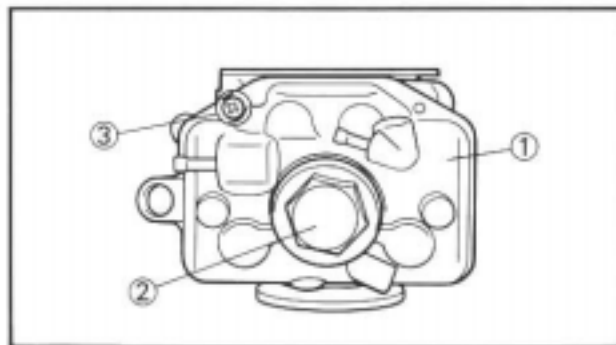

8. Install:
- Float chamber ①
 - Drain plug ②
 - Screw ③

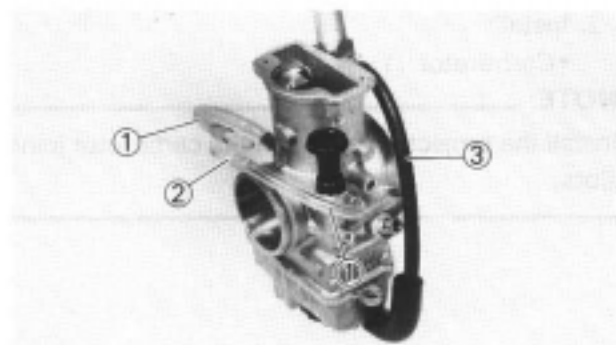

9. Install:
- Air vent hose ①
 - Joint ②
 - Hose ③

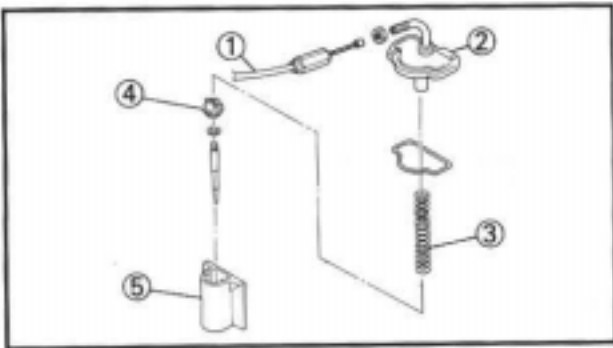

10. Install:

- Throttle cable ①
- Mixing chamber top ②
- Spring (throttle valve) ③
- Ring ④
- Throttle valve ⑤

NOTE: _____

While compressing the spring, connect the throttle cable.

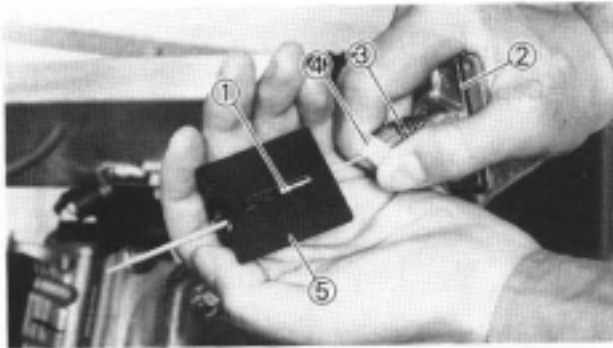

11. Install:

- Screw (mixing chamber top) ①

NOTE: _____

After installing, check the throttle grip for smooth movement.

4

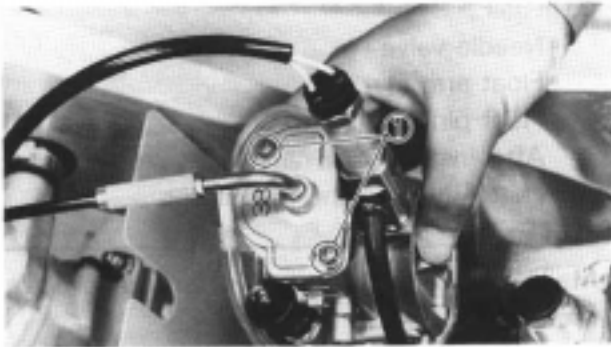

Carburetor installation

1. Install:

- Carburetor cover ①
- Clamp (carburetor joint) ②

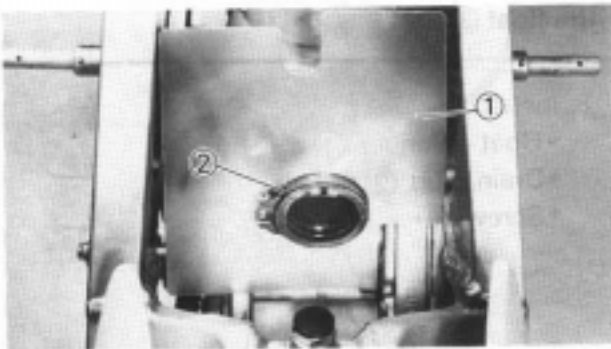

2. Install:

- Carburetor ①

NOTE: _____

Install the projection between the carburetor joint slots.





3. Tighten:
- Clamp (carburetor joint) ①



Clamp (carburetor joint):
2 Nm (0.2 m • kg, 1.4 ft • lb)

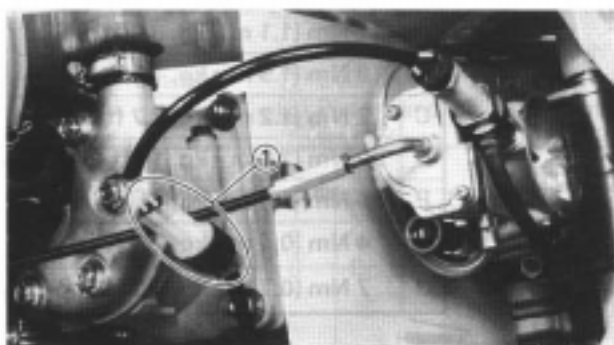

4. Connect:
- Solenoid valve lead ①



CYLINDER HEAD, CYLINDER AND PISTON



PREPARATION FOR REMOVAL

- *Remove the cowling.
- *Drain the cooling water.
- *Remove the following parts.
 - Fuel tank
 - Exhaust pipe
 - Plug cap and spark plug
- *Disconnect the radiator hose 4 at cylinder head side.
- *Remove the radiator installation bolts.

CYLINDER HEAD WARPAGE LIMIT:
0.03 mm (0.0012 in)

PISTON CLEARANCE:
0.045 - 0.055 mm (0.0018 - 0.0022 in)

PISTON RING SIDE CLEARANCE:
0.03 - 0.07 mm (0.0012 - 0.0028 in)

**PISTON RING END GAP
(INSTALLED):**
0.20 - 0.35 mm (0.008 - 0.014 in)

SPARK PLUG:
R6385-105P/NGK

SPARK PLUG GAP:
0.5 - 0.6 mm (0.020 - 0.024 in)

A 11 Nm (1.1 m • kg, 8.0 ft • lb)

B 19 Nm (1.9 m • kg, 13 ft • lb)

C 12 Nm (1.2 m • kg, 8.7 ft • lb)

D 20 Nm (2.0 m • kg, 14 ft • lb)

E 15 Nm (1.5 m • kg, 11 ft • lb)

F 4 Nm (0.4 m • kg, 2.9 ft • lb)

G 7 Nm (0.7 m • kg, 5.1 ft • lb)

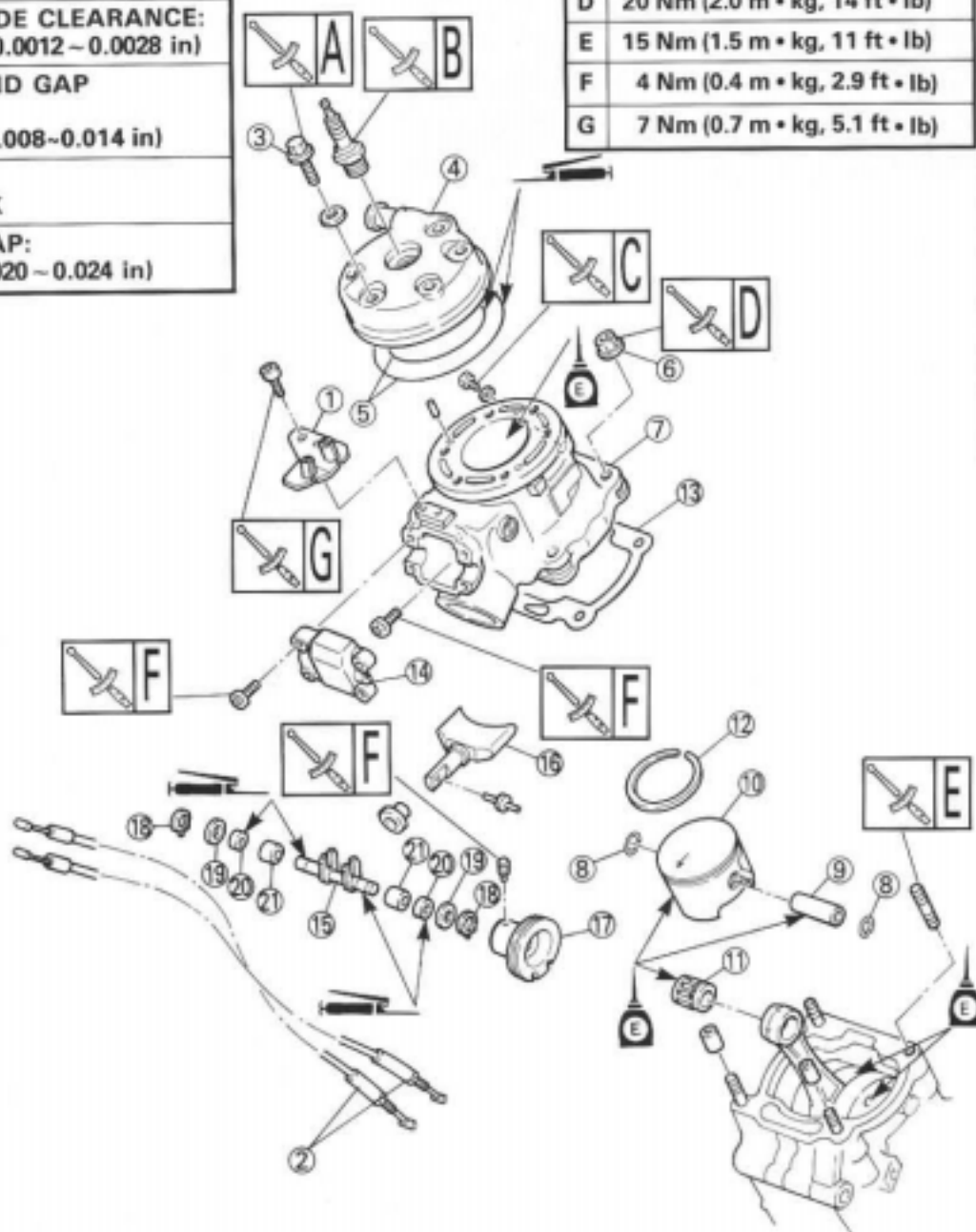



NOTE ON REMOVAL AND REASSEMBLY

- Before servicing, clean the parts, and take care so that foreign material does not enter the crankcase.
- Remove any gasket adhered to the contacting surface.
- Take care not to scratch the contacting surfaces when removing the cylinder and cylinder head.
- Take care not to scratch the cylinder and piston surfaces.
- For reassembly, the removed parts should be cleaned with solvent, and apply the engine oil onto the sliding surfaces.
- Take care so that the coolant does not enter the crankcase. If the coolant enters the crankcase, clean the inside of the crankcase and apply oil on it.
- When removing the cylinder head, the piston should be positioned at TDC (top dead center).

Extent of removal: ① Cylinder head removal ② Cylinder removal
 ③ Piston and piston ring removal ④ Power valve removal

Extent of removal	Order	Part name	Q'ty	Remarks
	1	Cable stay	1	Refer to "REMOVAL POINTS"
	2	YPVS cable	2	
	3	Bolt (cylinder head)	6	
	4	Cylinder head	1	
	5	O-ring	2	
	6	Nut (cylinder)	4	Refer to "REMOVAL POINTS".
	7	Cylinder	1	
	8	Clip (piston pin)	2	
	9	Piston pin	1	
	10	Piston	1	
	11	Small end bearing	1	
	12	Piston ring	1	
	13	Gasket (cylinder)	1	
	14	Valve cover	1	Refer to "REMOVAL POINTS".
	15	Valve shaft	1	
	16	Power valve	1	
	17	Valve pulley	1	
	18	Circlip	2	
	19	Plate washer	2	
	20	Oil seal	2	
	21	Solid bush	2	

4



REMOVAL POINTS

YPVS cable

1. Remove:
 - Bolt (cable stay) ①

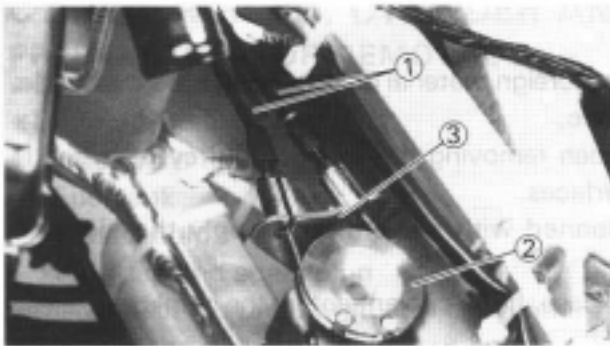

2. Remove:
- YPVS cable ①
 - From the valve pulley ②.

NOTE: _____
 Remove the YPVS cable together with the cable stay ③ .

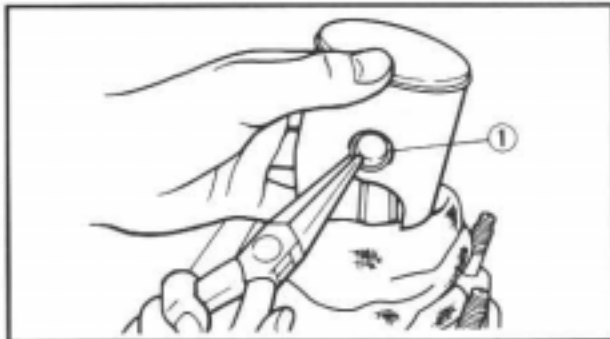

Piston and piston ring

1. Remove:
- Piston pin clip ①

NOTE: _____
 Before removing piston pin clip, cover crankcase with a clean rag to prevent piston pin clip from falling into crankcase cavity.

2. Remove:
- Piston pin ①
 - Piston ②
 - Small end bearing ③

NOTE: _____
 Before removing the piston pin, deburr the clip groove and pin hole area. If the piston pin groove is deburred and piston pin is still difficult to remove, use the piston pin puller ④.

4

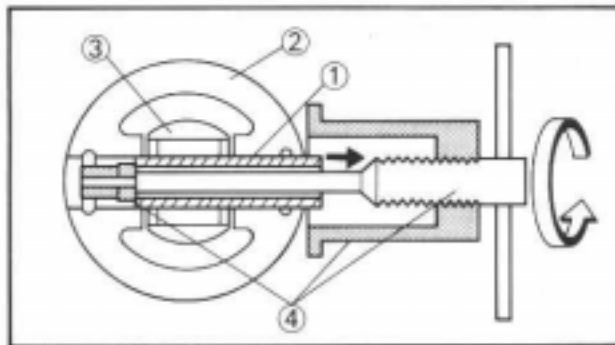

	<p>Piston pin puller: YU-01304/90890-01304</p>
--	--

CAUTION: _____
 Do not use a hammer to drive the piston pin out.

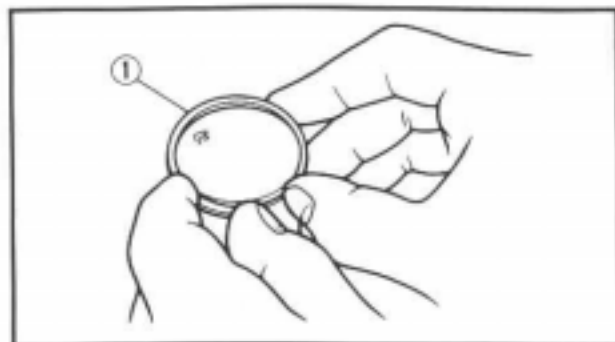

3. Remove:
- Piston ring ①

NOTE: _____
 Take care not to scratch the piston and damage the piston ring.

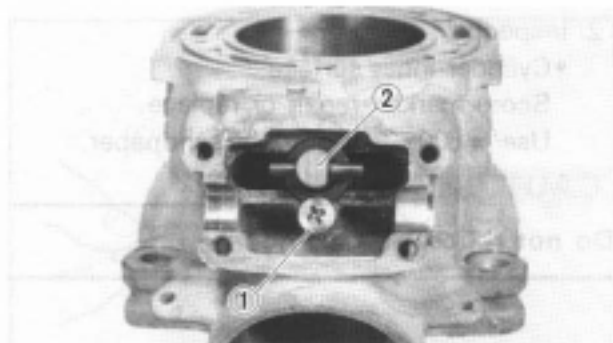
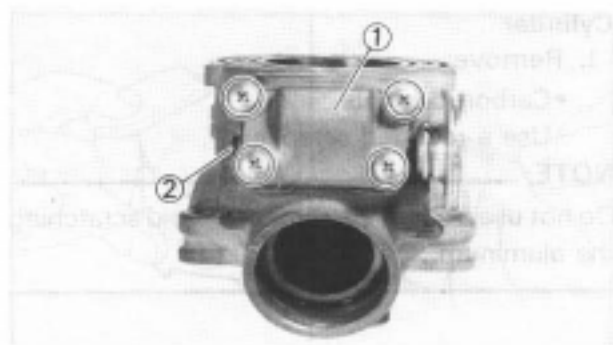
**Power valve**

1. Remove:

- Valve cover ①
- Valve shaft ②

2. Remove:

- Screw (power valve) ①
- Power valve ②

INSPECTION**Cylinder head**

1. Remove:

- Carbon deposits
- Use a rounded scraper ①.

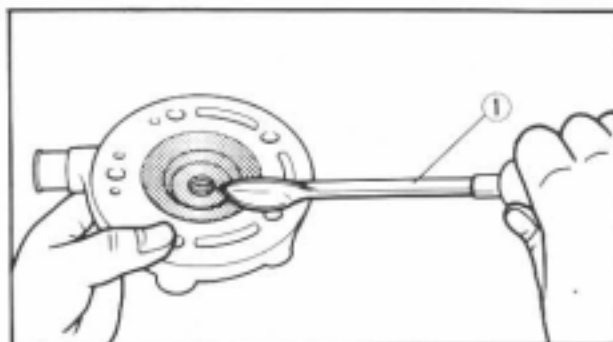
**NOTE:**

Take care to avoid damaging the spark plug threads. Do not use a sharp instrument. Avoid scratching the aluminum.

2. Inspect:

- Cylinder head water jacket
- Crust of minerals/Rust → Remove.
- Cylinder head warpage
- Out of specification → Re-surface.

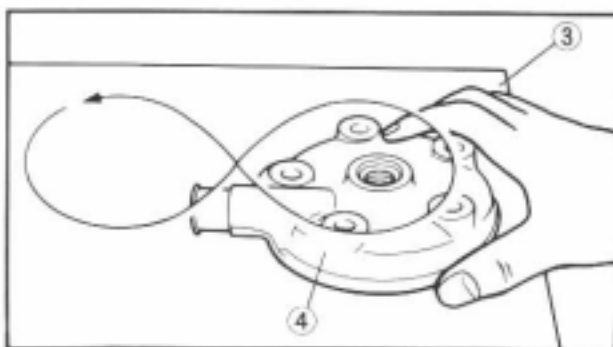
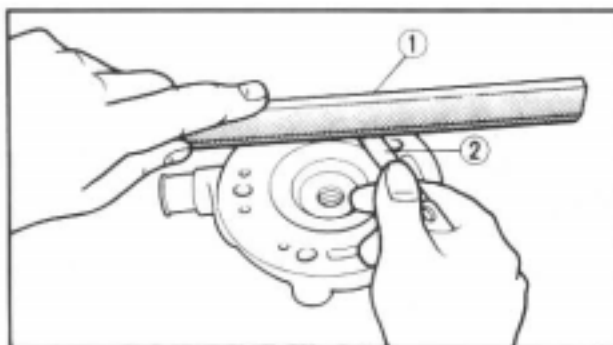
**Warpage measurement and re-surface-ment steps:**

- Attach a straightedge ① and a thickness gauge ② on the cylinder head.
- Measure the warpage.

**Warpage limit:**

0.03 mm (0.0012 in)

- If the warpage is out of specification, re-surface the cylinder head.
- Place a 400 – 600 grit wet sandpaper ③ on the surface plate, and re-surface the head ④ using a figure-eight sanding pattern.

NOTE:

Rotate the head several times to avoid removing too much material from one side.

4

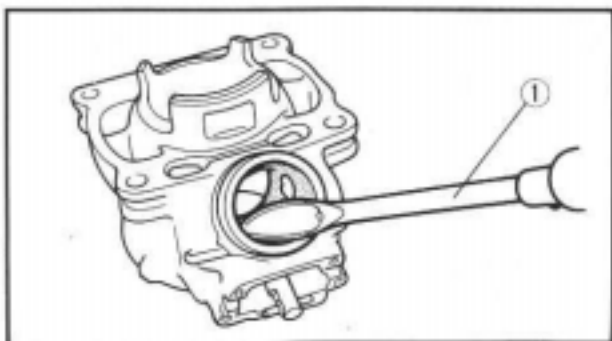

Cylinder

1. Remove:

- Carbon deposits
Use a rounded scraper ①.

NOTE: _____

Do not use a sharp instrument. Avoid scratching the aluminum.

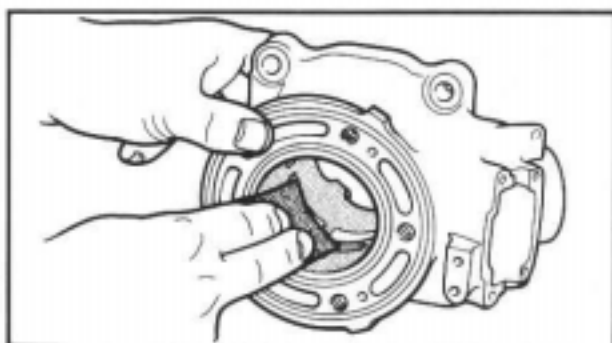

2. Inspect:

- Cylinder inner surface
Score marks → repair or replace.
Use #600 ~ 800 grit wet sandpaper.

CAUTION: _____

Do not rebore the cylinder.

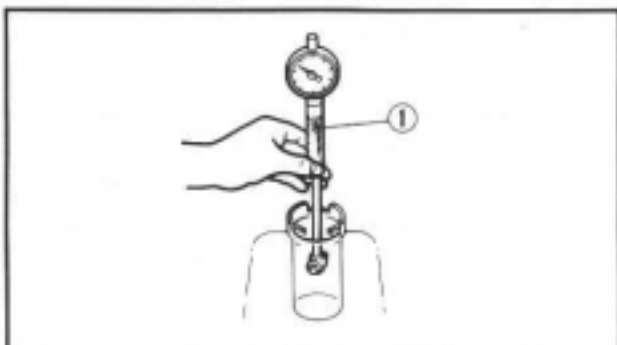

3. Measure:

- Cylinder bore "C"
Use cylinder gauge ①.
Out of limit → Replace.

NOTE: _____

Measure the cylinder bore "C" in parallel (A, B, C) to and at right angles to the crankshaft (a, b). Then, find the average of the measurements.

4

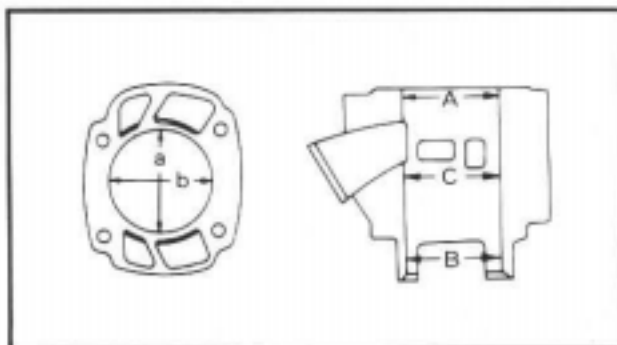

	Standard	Wear limit
 Cylinder bore "C"	56.000 ~ 56.020 mm (2.2047 ~ 2.2055 in)	56.1 mm (2.209 in)
Taper "T"	—	0.05 mm (0.0020 in)
C = Maximum Aa ~ Cb T = (Maximum Aa, or Ab) - (Maximum Ba, or Bb)		

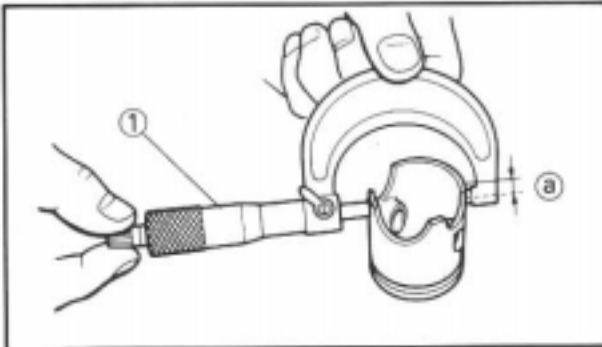
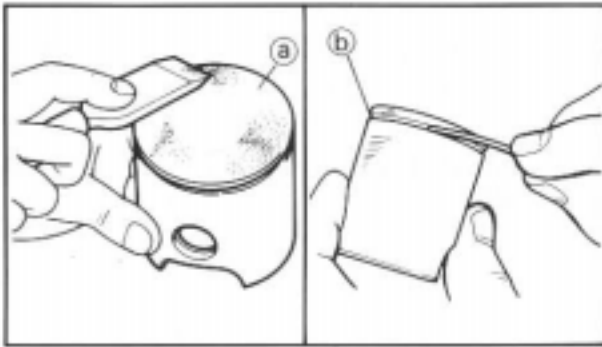

Piston

1. Remove:
 - Carbon deposits
From the piston crown (a) and ring groove (b).
2. Inspect:
 - Piston wall
Score marks → Repair or replace.
3. Measure:
 - Piston skirt diameter
Use micrometer (1).
Measure specific distance (a) from the bottom edge.
Out of specification → Replace.

	Distance (a)	Piston dia.
	19 mm (0.75 in)	55.950 ~ 55.970 mm (2.2028 ~ 2.2035 in)

4

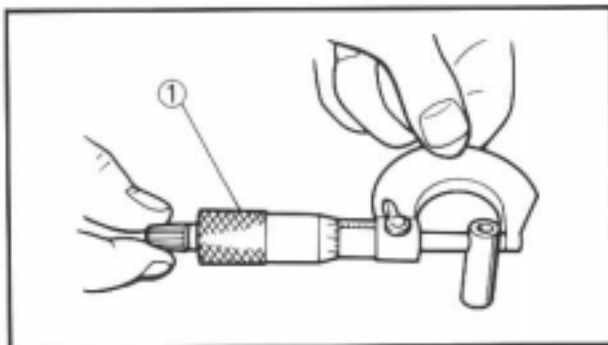
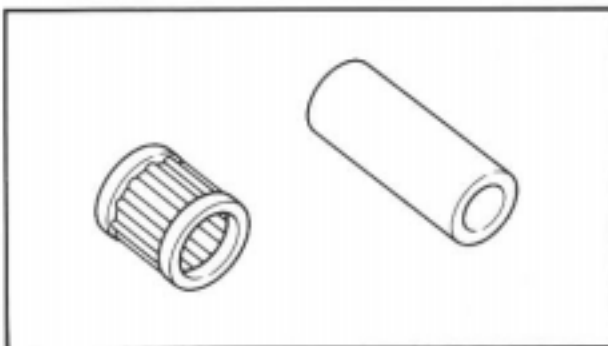

Piston pin and small end bearing

1. Inspect:
 - Piston pin
 - Small end bearing
Signs of heat discoloration → Replace.
2. Measure:
 - Piston pin outside diameter
Use micrometer (1).
Out of limit → Replace.

	Piston pin outside diameter:	
	Standard	< Limit >
	15.995 ~ 16.000 mm (0.6297 ~ 0.6299 in)	15.975 mm (0.6289 in)

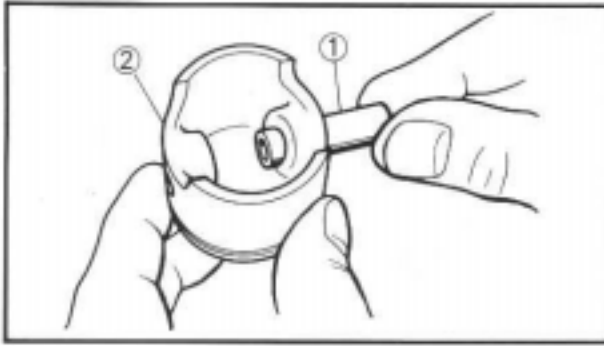

3. Check:

- Free play (when the piston pin ① is in place in the piston ②)
There should be no noticeable for the play.
Free play exists → Replace piston pin and/or piston.

4. Install:

- Small end bearing
- Piston pin
Into the small end of connecting rod.

4

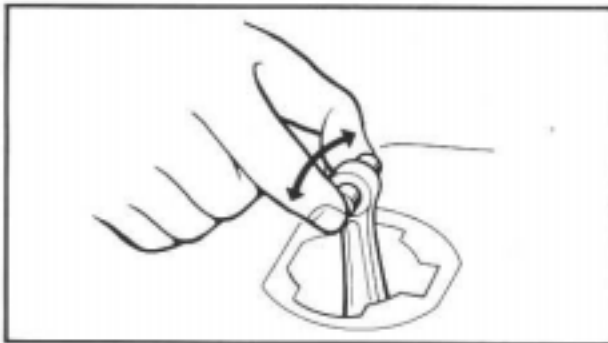

5. Check:

- Free play
There should be no noticeable free play.
Free play exists → Inspect the connecting rod for wear/Replace the pin and/or connecting rod as required.

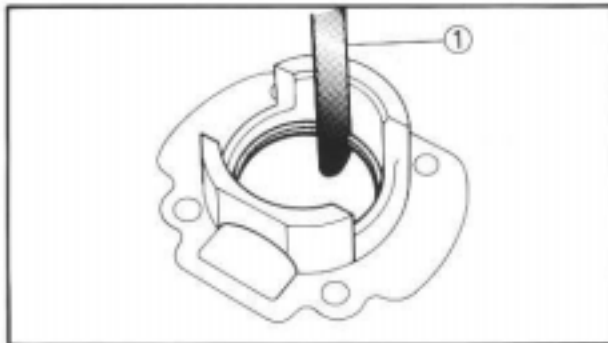

Piston ring

1. Install:

- Piston ring
Into the cylinder.
Push the ring with the piston crown.

2. Measure:

- End gap
Out of specification → Replace.
Using a Thickness Gauge ①.

Ring end gap (installed):	
Standard	< Limit >
0.20~0.35mm (0.008~0.014 in)	0.55 mm (0.022in)

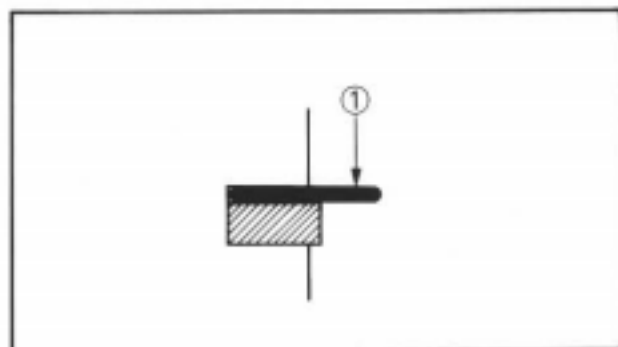
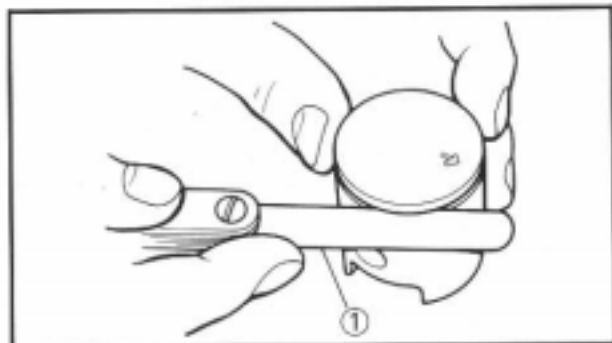

3. Measure:

- Side clearance

Out of limit → Replace piston and/or ring.

Using a thickness gauge ①.

Side clearance:	
Standard	< Limit >
0.03 – 0.07 mm (0.0012 – 0.0028 in)	0.1 mm (0.004 in)

NOTE:

Check at several points.

Piston clearance

1. Calculate:

- Piston clearance

Out of limit → Replace piston, and piston ring and/or cylinder.

Refer to "CYLINDER BORE" and "PISTON DIAMETER".

4

$$\text{PISTON CLEARANCE} = \text{CYLINDER BORE} - \text{PISTON DIAMETER}$$

Piston clearance:	
Standard	< Limit >
0.045 ~ 0.055 mm (0.0018 ~ 0.0022 in)	0.1 mm (0.004 in)

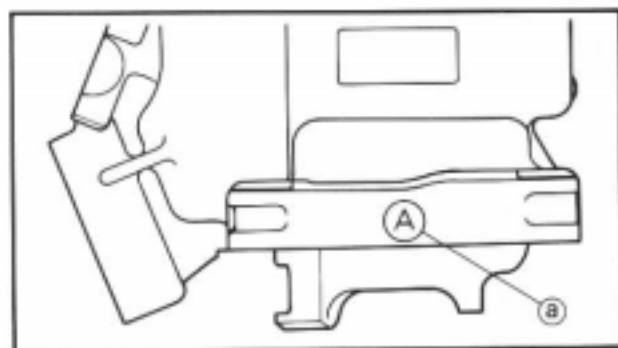

Combination of piston and cylinder

1. Cylinder mark:

Cylinder mark (a)	Cylinder size
A	56.000 – 56.005 mm (2.2048 – 2.2049 in)
B	56.005 – 56.010 mm (2.2049 – 2.2051 in)
C	56.010 – 56.016 mm (2.2051 – 2.2054 in)
D	56.016 – 56.020 mm (2.2054 – 2.2055 in)

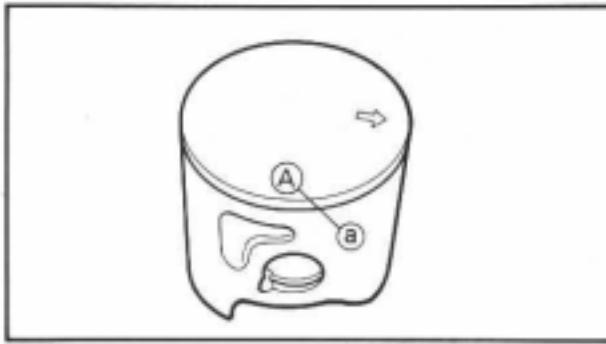

2. Piston mark:

Piston mark (a)	Size
A (red)	55.950 ~ 55.954 mm (2.2028 ~ 2.2029 in)
B (orange)	55.955 ~ 55.960 mm (2.2030 ~ 2.2031 in)
C (green)	55.961 ~ 55.965 mm (2.2032 ~ 2.2033 in)
D (purple)	55.965 ~ 55.970 mm (2.2033 ~ 2.2035 in)

3. Combination:

Combine the piston and cylinder by the following chart.

Cylinder mark	Piston mark
A	A (red)
B	B (orange)
C	C (green)
D	D (purple)

NOTE:

When you purchase a cylinder, you cannot designate its size. Choose the piston that matches the above chart.

4

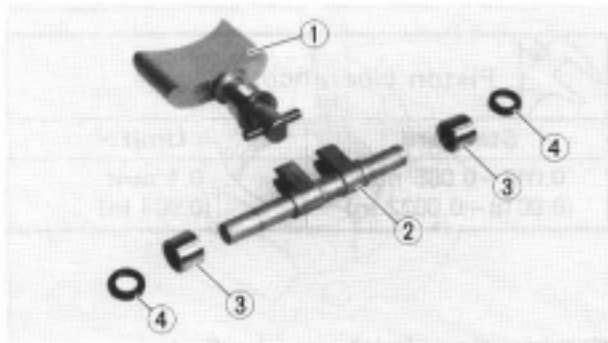

Power valve

1. Inspect:

- Power valve ①
Wear/Damage → Replace.
Carbon deposits → Remove.
- Valve shaft ②
- Solid bush ③
- Oil seal ④
Wear/Damage → Replace.

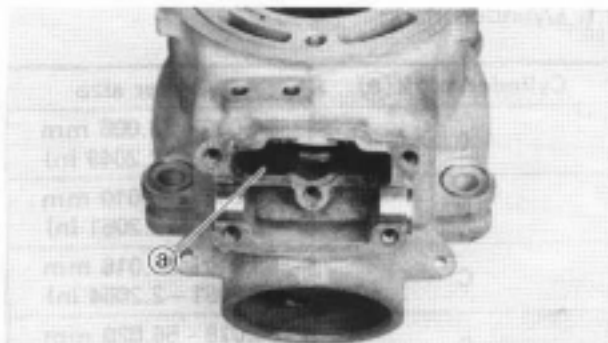

Power valve hole on cylinder

1. Remove:

- Carbon deposits
From power valve hole surface (a).

NOTE:

Do not use a sharp instrument. Avoid scratching the aluminum.

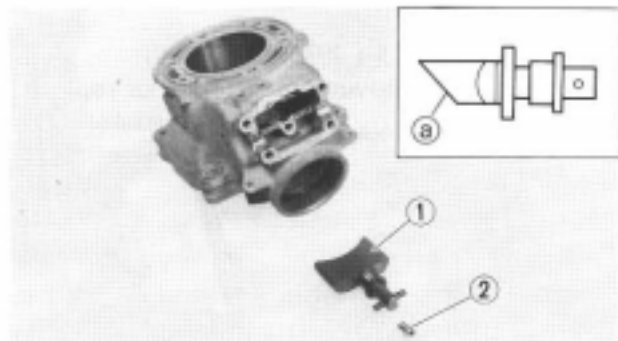
**ASSEMBLY AND INSTALLATION****Power valve**

1. Install:

- Power valve (1)
- Screw (power valve) (2)

NOTE:

Install the power valve at cut-away faced (a) for down side.



Screw (power valve):
4 Nm (0.4 m•kg, 2.9 ft•lb)

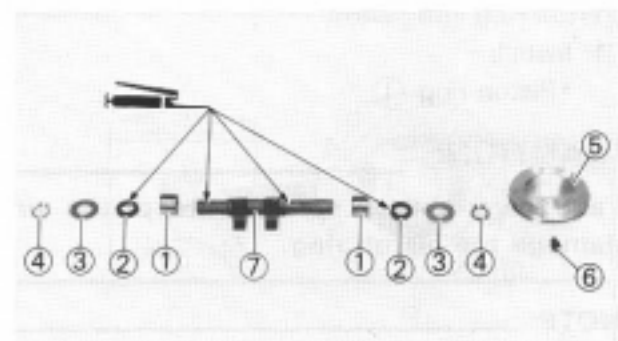

2. Install:

- Solid bush (1)
- Oil seal (2)
- Plain washer (3)
- Circlip (4)
- Valve pulley (5)
- Screw (valve pulley) (6)
To valve shaft (7).

NOTE:

- Apply the lithium soap base grease on the valve shaft and oil seal lip.
- Always use a new circlip.



Screw (valve pulley):
4 Nm (0.4 m•kg, 2.9 ft•lb)

3. Lock the pulley holding screw using an appropriate wire around the groove on the valve pulley.

4. Install:

- Valve shaft (1)
- Valve cover (2)
- Screw (valve cover) (3)

NOTE:

- When installing the valve shaft into the cylinder, lightly touch the solid bush (4) with the oil seal (5).
- Clean the contacting surface of the valve cover and cylinder before applying the sealant.



Quick gasket®
ACC-11001-05-01
Yamaha bond No. 1215:
90890-85505



Screw (valve cover):
4 Nm (0.4 m•kg, 2.9 ft•lb)

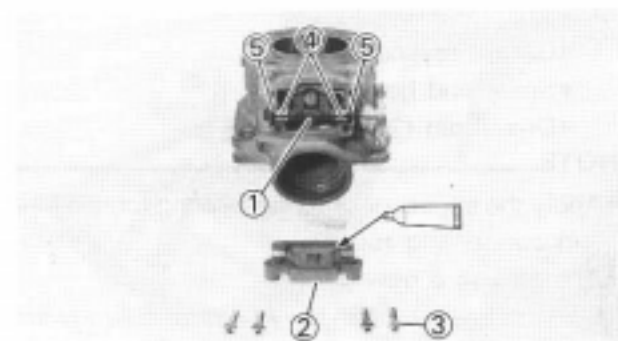
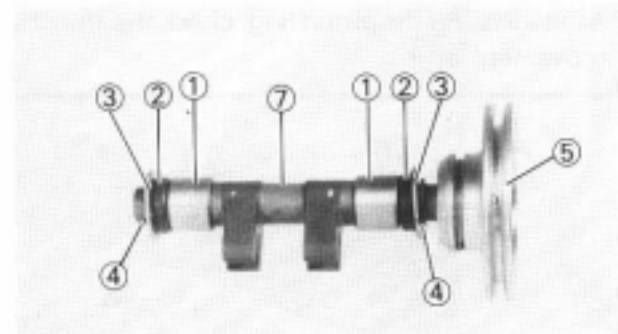

4

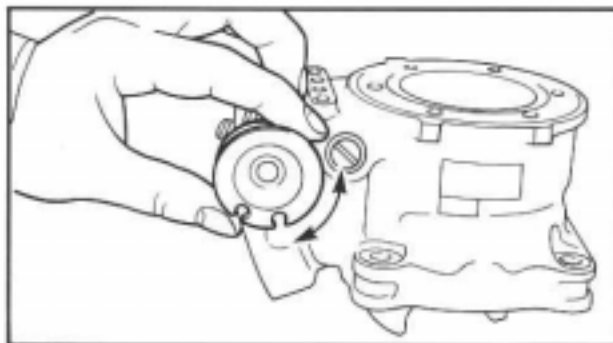

5. Check:

- Power valve smooth movement
- Unsmooth movement → Repair or replace.



Piston ring and piston

1. Install:

- Piston ring ①

CAUTION:

Take care not to scratch the piston or damage the piston ring.

NOTE:

- Align the piston ring gap with the pin ②.
- After installing the piston ring, check the smooth movement of it.

4

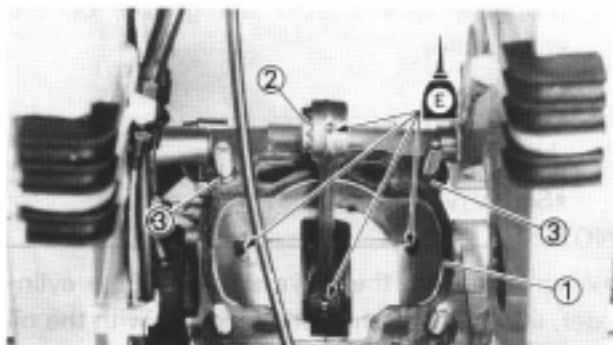

2. Install:

- Gasket (cylinder) ①
- Small end bearing ②
- Dowel pin ③

NOTE:

- Apply the engine oil onto the bearing (crankshaft and connecting rod).
- Always use a new gasket.
- Install the gasket with the seal print side toward the crankcase.

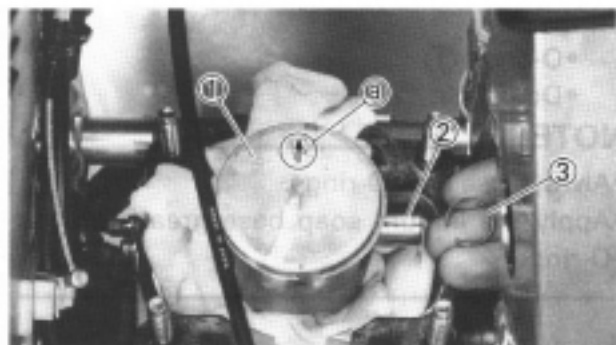

3. Install:

- Piston ①
- Piston pin ②
- Piston pin clip ③

NOTE:

- The arrow (a) on piston must point to exhaust side.
- Before installing piston pin circlip, cover crankcase with a clean rag to prevent circlip from falling into crankcase cavity.

CAUTION:

- Do not allow the clip open ends to meet the piston pin slot.
- Always use a new piston pin clip.

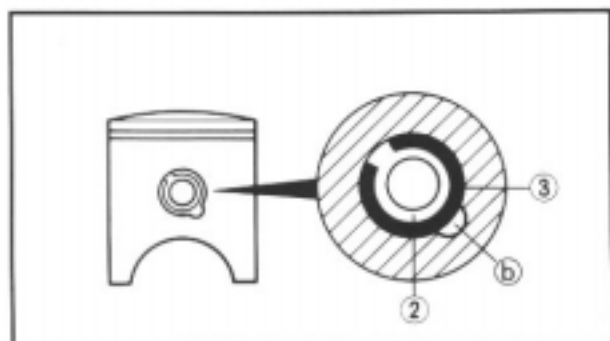

Cylinder head and cylinder

1. Apply:

- Engine oil
To piston ①, piston ring ② and cylinder inner surface.

2. Install:

- Cylinder ①

CAUTION:

Make sure the rings are properly positioned. Install the cylinder with one hand while compressing the piston ring with the other hand.

NOTE:

After installing, check the smooth movement of the piston.

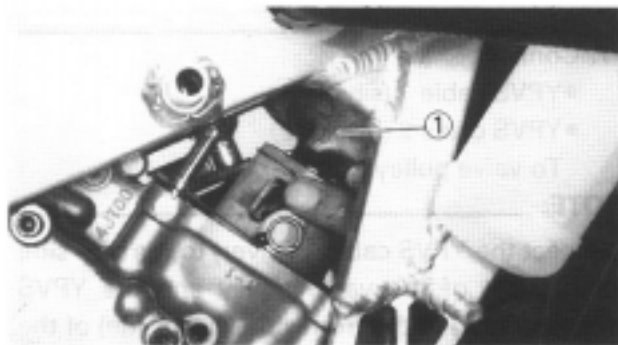

3. Tighten:

- Nut (cylinder) ①

NOTE:

Tighten the nuts in stages, using a crisscross pattern.

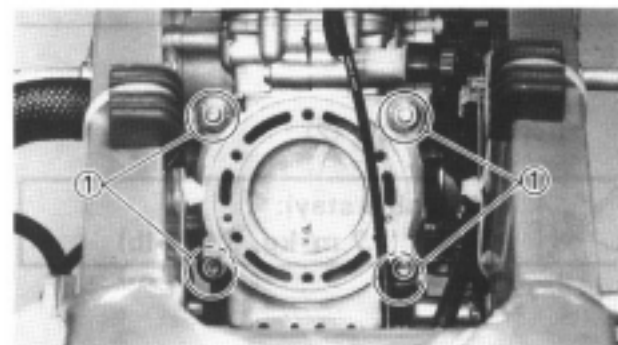

Nut (cylinder):

20 Nm (2.0 m·kg, 14 ft·lb)

4

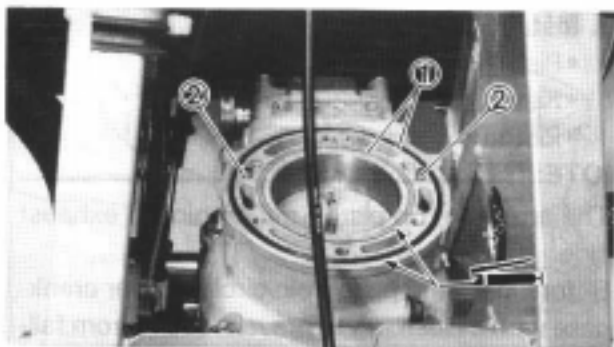

4. Install:

- O-rings ①
- Dowel pin ②

NOTE:

- Always use new O-rings.
- Apply the lithium soap base grease on the O-rings.

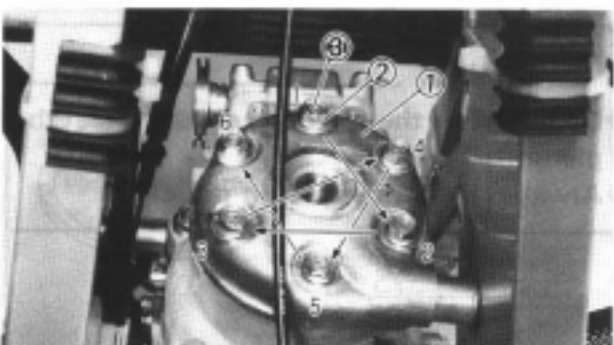

5. Install:

- Cylinder head ①
- Copper washer ②
- Bolt (cylinder head) ③

NOTE:

Tighten the bolts (cylinder head) in stage, using a crisscross pattern.



Bolt (cylinder head):
11 Nm (1.1 m•kg, 8.0 ft•lb)

6. Install:

- YPVS cable 1 (silver) ①
- YPVS cable 2 (black) ②
- To cable stay ③.

NOTE:

Install the YPVS cable 1 (silver) to the rear side (open side) of the cable stay and YPVS cable 2 (black) to the front side (close side) of the cable stay.

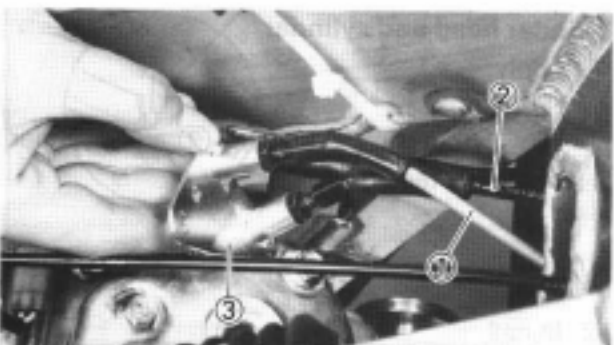

7. Connect:

- YPVS cable 1 (silver) ①
- YPVS cable 2 (black) ②
- To valve pulley ③.

NOTE:

Connect the YPVS cable 1 (silver) to the rear side (open side) of the valve pulley and the YPVS cable 2 (black) to the front side (close side) of the valve pulley.

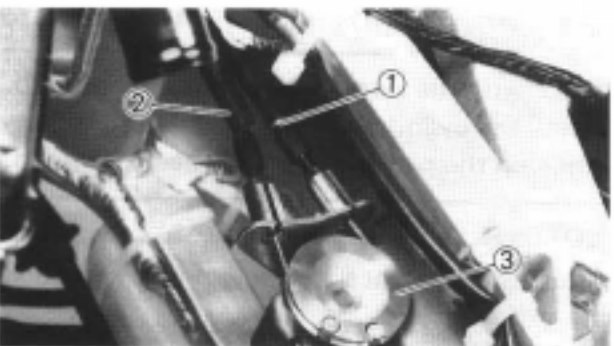

8. Install:

- Cable stay ①
- Bolt (cable stay) ②



Bolt (cable stay):
7 Nm (0.7 m•kg, 5.1 ft•lb)

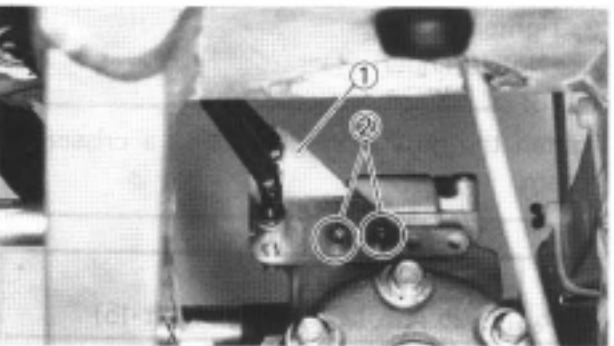

4



9. Adjust:

- YPVS cable

Refer to "YPVS OPEN SIDE CABLE ADJUSTMENT" and "YPVS CLOSE SIDE CABLE ADJUSTMENT" section in the CHAPTER 3.

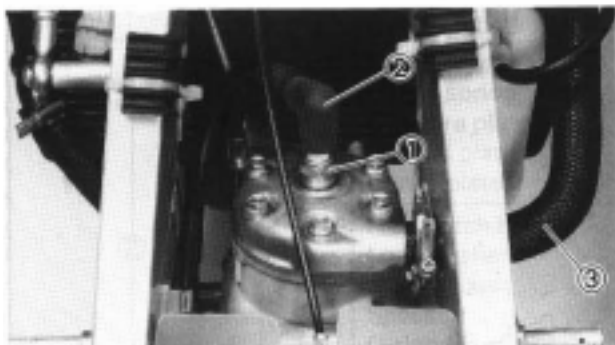

10. Install:

- Spark plug ①
- Plug cap ②
- Radiator hose clamp ③

**Spark plug:**

19 Nm (1.9 m·kg, 13 ft·lb)

Radiator hose clamp:

2 Nm (0.2 m·kg, 1.4 ft·lb)



CLUTCH PREPARATION FOR REMOVAL



- * Remove the lower cowl.
- * Disconnect clutch cable at engine side.

FRICITION PLATE WEAR LIMIT:
2.7 mm (0.106 in)

CLUTCH PLATE WARP LIMIT:
0.1 mm (0.039 in)

CLUTCH SPRING FREE LENGTH LIMIT:
35.0 mm (1.378 in)

A 6 Nm (0.6 m • kg, 4.3 ft • lb)

B 11 Nm (1.1 m • kg, 8.0 ft • lb)

C 50 Nm (5.0 m • kg, 36 ft • lb)

4

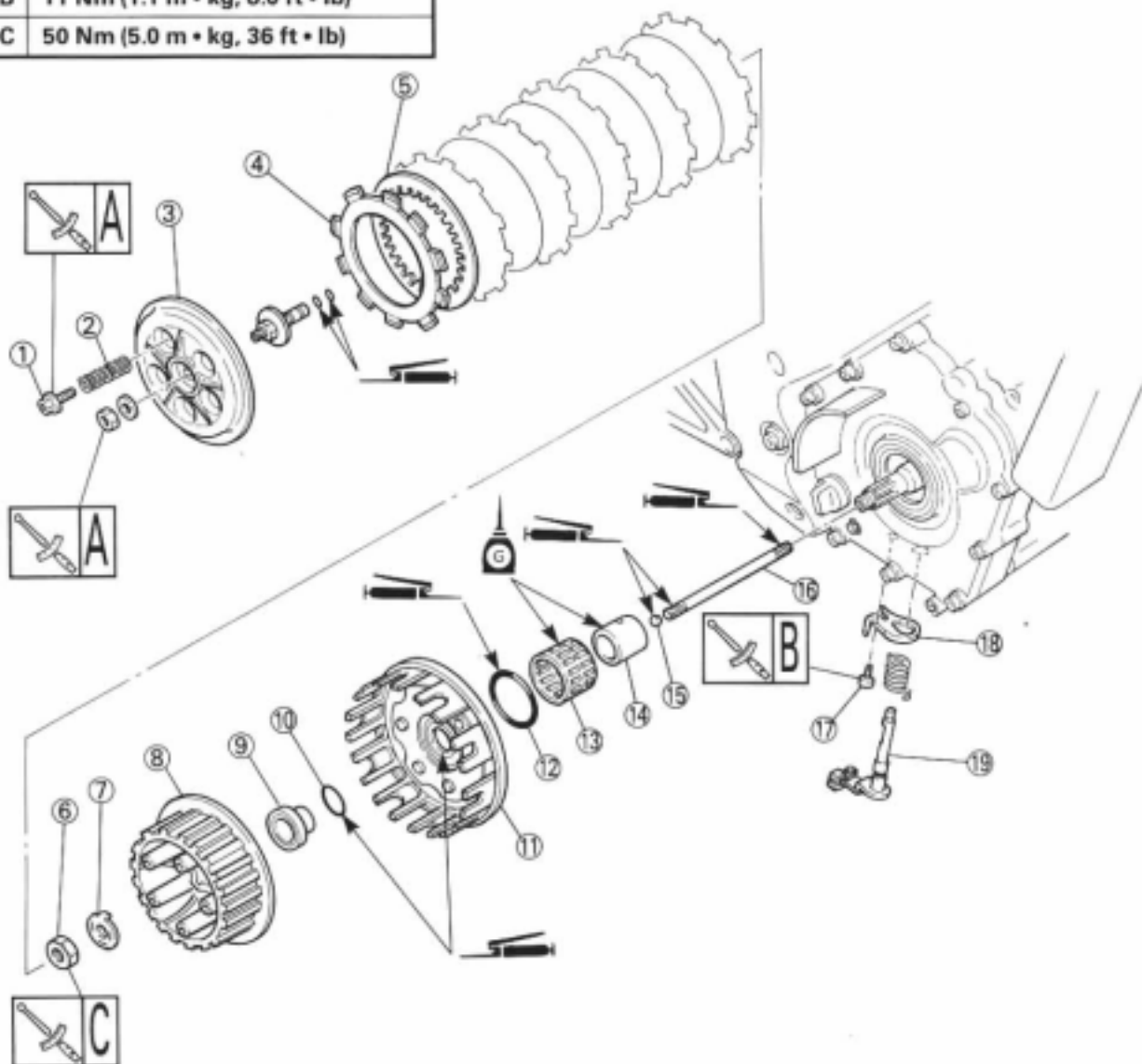



NOTE ON REMOVAL AND REASSEMBLY

- Before servicing, clean the parts, and take care so that foreign material does not enter the crankcase.
- For reassembly, the removed parts should be cleaned with solvent, and apply the transmission oil onto the sliding surface.

Extent of removal: ① Clutch plate and friction plate removal ② Clutch housing removal
③ Push rod and push lever removal

Extent of removal	Order	Part name	Q'ty	Remarks
①	1	Screw (clutch spring)	5	
	2	Clutch spring	5	
	3	Pressure plate	1	
	4	Friction plate	6	
	5	Clutch plate	5	
②	6	Nut (clutch boss)	1	Use special tool. Refer to "REMOVAL POINTS".
	7	Lock washer	1	
	8	Clutch boss	1	
	9	Spacer 2	1	
	10	O-ring (small)	1	
	11	Clutch housing	1	
③	12	O-ring (large)	1	
	13	Bearing	1	
	14	Spacer 1	1	
	15	Ball	1	
	16	Push rod	1	
	17	Bolt (seat plate)	1	
	18	Seat plate	1	
	19	Push lever axle	1	

4

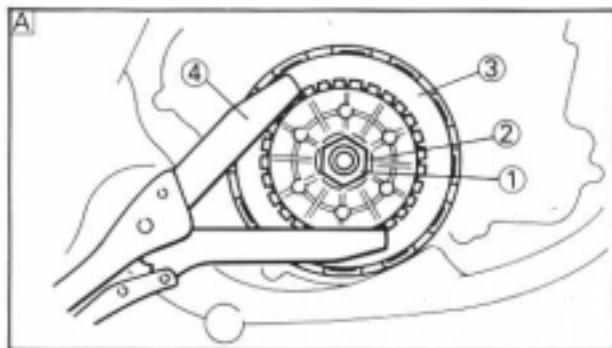

REMOVAL POINTS

Clutch boss

1. Remove:

- Nut ①
- Lock washer ②
- Clutch boss ③

NOTE:

Straighten the lock washer tab and use the clutch holder ④, ⑤ to hold the clutch boss.

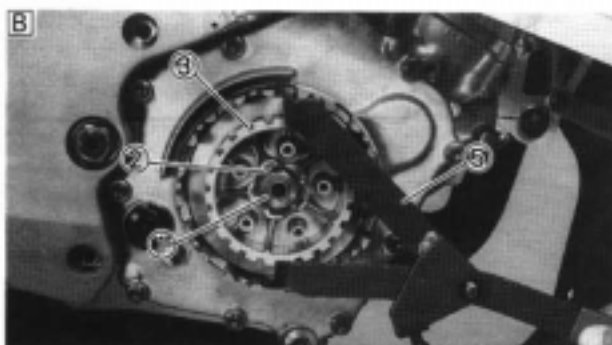

Clutch holder:

YM-91042 ④
90890-04086 ⑤

Ⓐ For USA and CDN

Ⓑ Except for USA and CDN

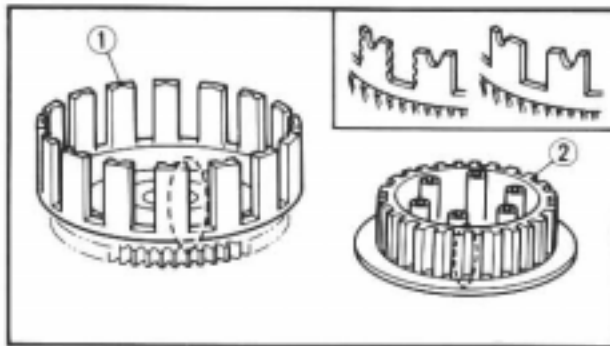
**INSPECTION****Clutch housing and boss**

1. Inspect:

- Clutch housing ①
Cracks/Wear/Damage → Replace.
- Clutch boss ②
Scoring/Wear/Damage → Replace.

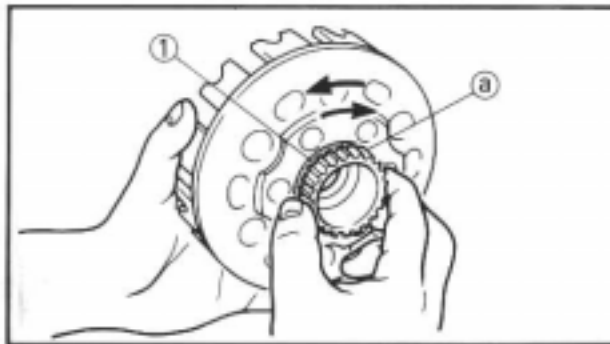
**Clutch housing**

1. Check:

- Circumferential play
Free play exists → Replace.
- Gear teeth (a)
Wear/Damage → Replace.
- O-ring ①
Damage → Replace.

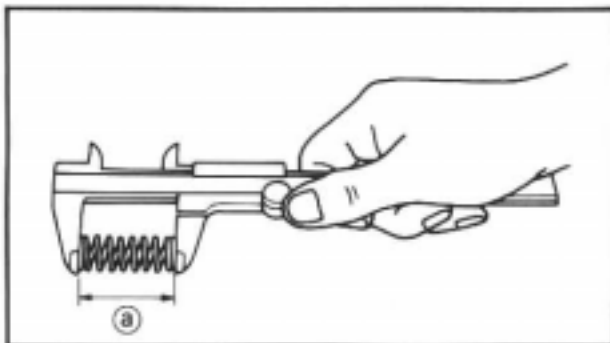
**Clutch spring**

1. Measure:

- Clutch spring free length (a)
Out of specification → Replace springs as a set.

Clutch spring free length:	
Standard	< Limit >
36.0 mm (1.417 in)	35.0 mm (1.378 in)

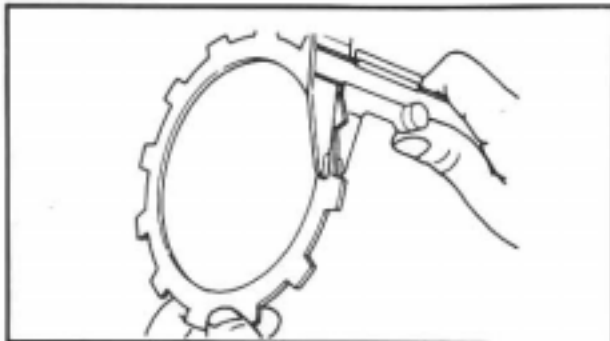
**Friction plate**

1. Measure:

- Friction plate thickness
Out of specification → Replace friction plate as a set.
Measure at all four points.

Friction plate thickness:	
Standard	< Limit >
2.9 ~ 3.1 mm (0.114 ~ 0.122 in)	2.7 mm (0.106 in)

4

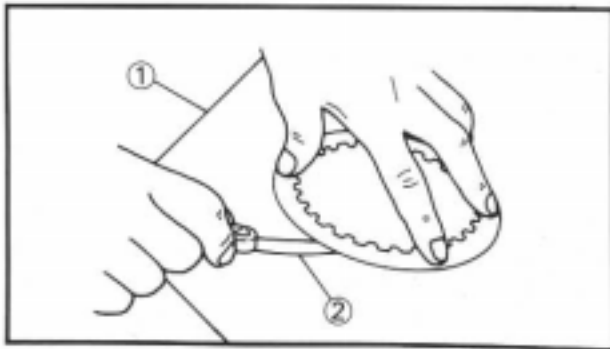

Clutch plate

1. Measure:

- Clutch plate warpage
Out of specification → Replace clutch plate as a set.
- Use a surface plate ① and thickness gauge ②.



Warp limit:

0.1 mm (0.004 in)

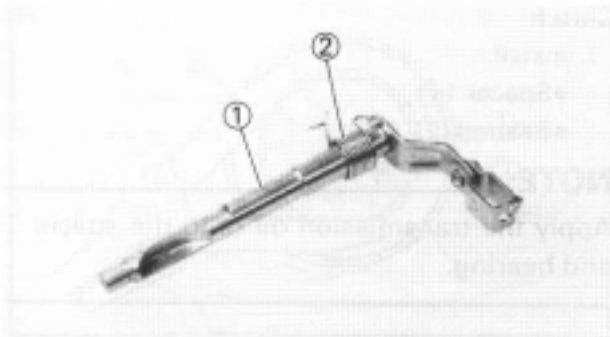

Push lever axle

1. Inspect:

- Push lever axle ①
Wear/Damage → Replace.
- Torsion spring ②
Broken/Damage → Replace.

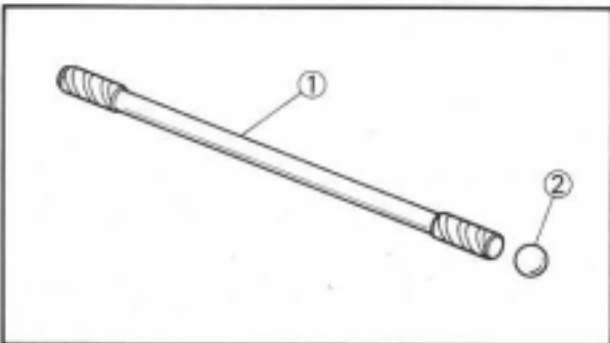

Push rod axle

1. Inspect:

- Push rod ①
- Ball ②
Wear/Damage/Bend → Replace.



Bending limit:

0.2 mm (0.008 in)

NOTE:

The bending value is shown by one half of the dial gauge reading.

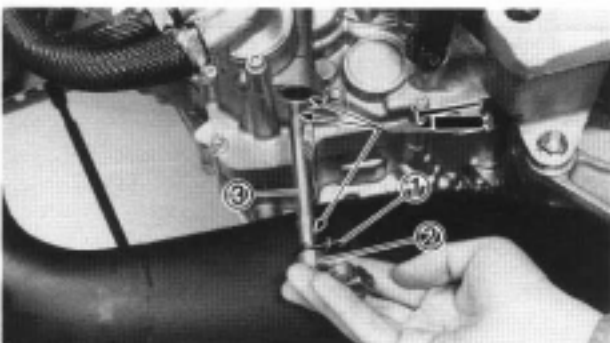
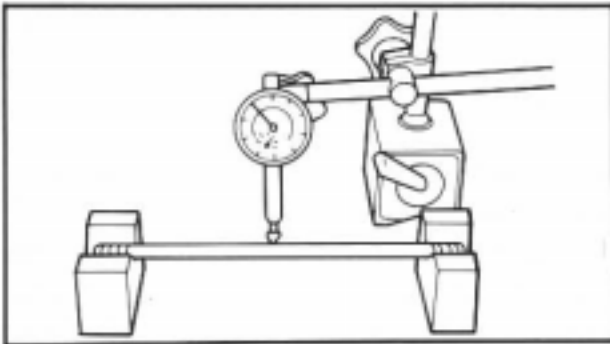

ASSEMBLY AND INSTALLATION

Push lever axle

1. Install:

- Seat plate ①
- Torsion spring ②
- Push lever axle ③

NOTE:

Apply the lithium soap base grease onto the push lever axle, oil seal lip and bearing.

4

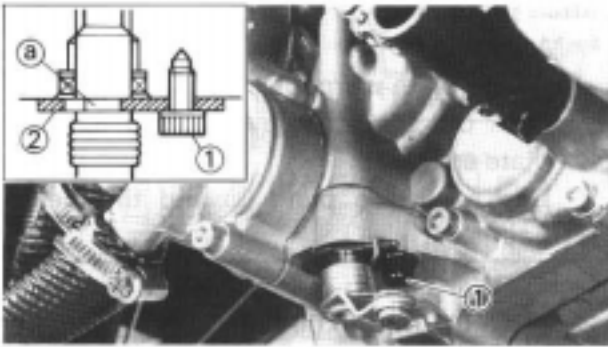

2. Install:
 • Bolt (seat plate) ①

NOTE:

Fit the seat plate ② in the groove ③ of the push lever axle and tighten the installation bolt.

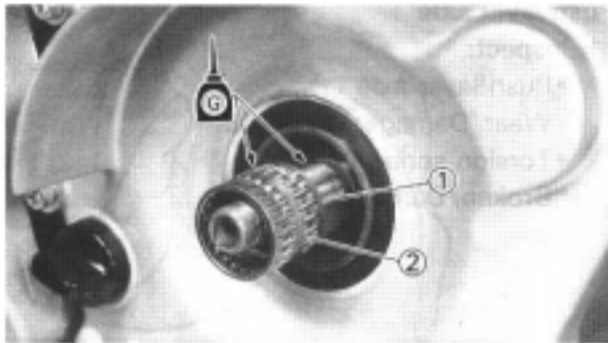

Bolt (seat plate):
 11 Nm (1.1 m•kg, 8.0 ft•lb)

**Clutch**

1. Install:
 • Spacer 1 ①
 • Bearing ②

NOTE:

Apply the transmission oil onto the spacer 1 and bearing.

2. Install:
 • O-ring ①
 To spacer 2 ②.

NOTE:

- Always use a new O-ring.
- Apply the lithium soap base grease on the O-ring.

3. Install:
 • O-ring ①
 • Spacer 2 ②
 To clutch housing ③.

NOTE:

- Always use a new O-ring.
- Apply the lithium soap base grease on the O-ring and oil seal lip.
- When installing the spacer 2, pay careful attention to the clutch housing oil seal lip.

4

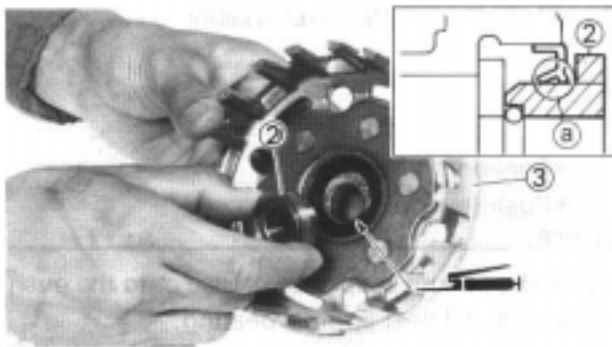
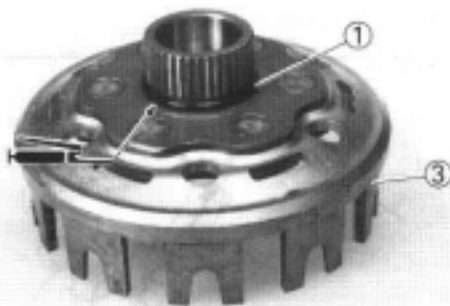
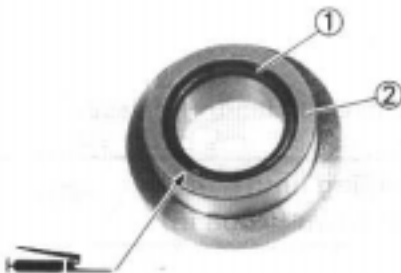

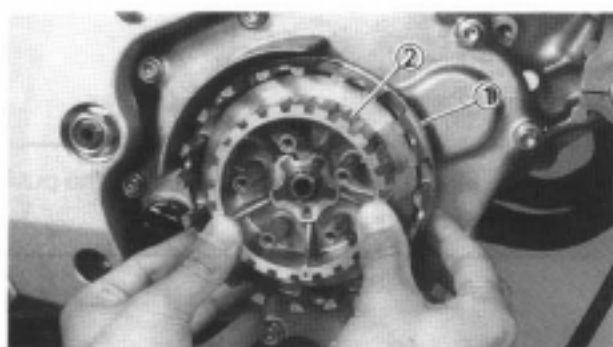

4. Install:
- Clutch housing (1)
 - Clutch boss (2)

NOTE: _____
 Install the clutch housing with the clutch boss pushed on it so that the spacer 2 will not come off.

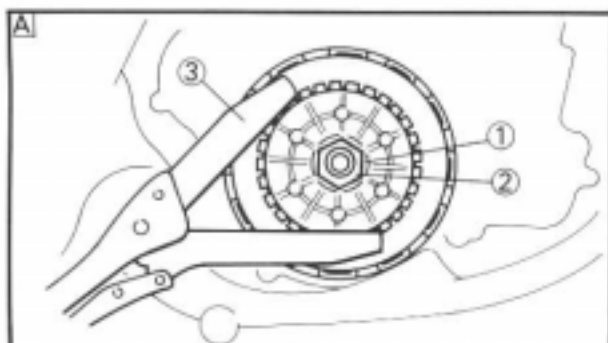

5. Install:
- Lock washer (1)
 - Nut (clutch boss) (2)

NOTE: _____
 •Always use a new lock washer.
 •Use the clutch holder (3), (4) to hold the clutch boss.

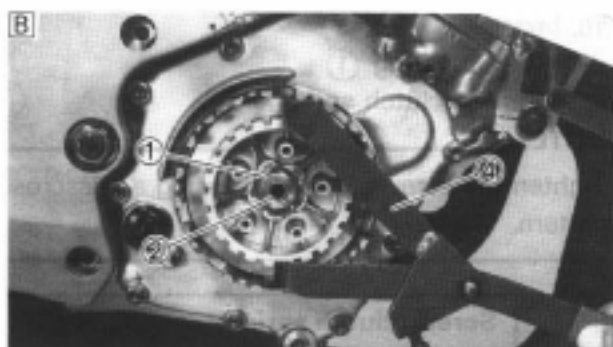

	Clutch holder:	
	YM-91042	(3)
	90890-04086	(4)

- A** For USA and CDN
B Except for USA and CDN

	Nut (clutch boss):	
	50 Nm (5.0 m•kg, 36 ft•lb)	

6. Bend the lock washer (1) tab.



7. Install:
- Friction plate (yellow) (1)
 - Clutch plate (2)
 - Friction plate (brown) (3)

NOTE: _____
 •Install the clutch plates and friction plates alternately on the clutch boss, starting with a friction plate and ending with a friction plate.
 •Yellow colored friction plates are used for the first and final.
 •This machine is equipped with a dry type clutch. Be sure to clean with solvent or replace if grease or oil contacts either clutch or friction plates.

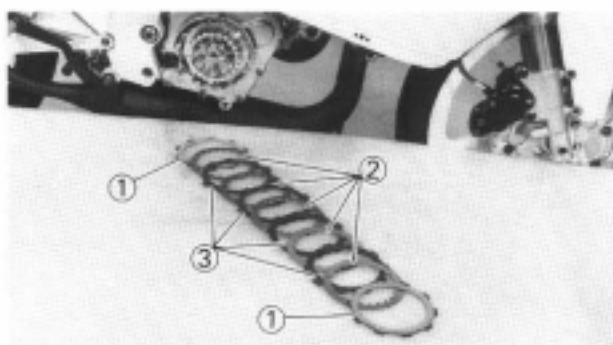

4

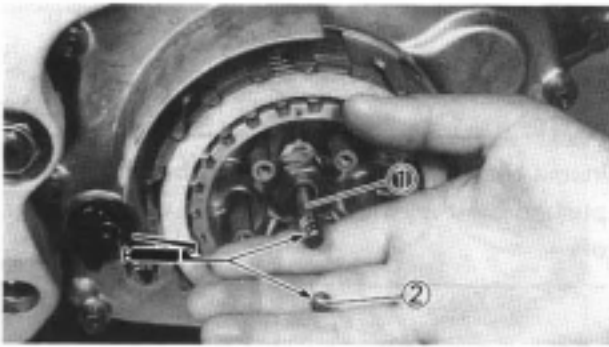

8. Install:
- Push rod ①
 - Ball ②

NOTE:

Apply the lithium-soap base grease onto the push rod and ball.

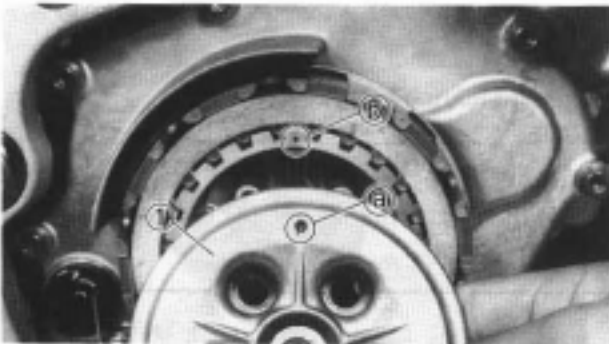

9. Install:
- Pressure plate ①

NOTE:

Align the punch mark (a) on the pressure plate with the punch mark (b) on the clutch boss.

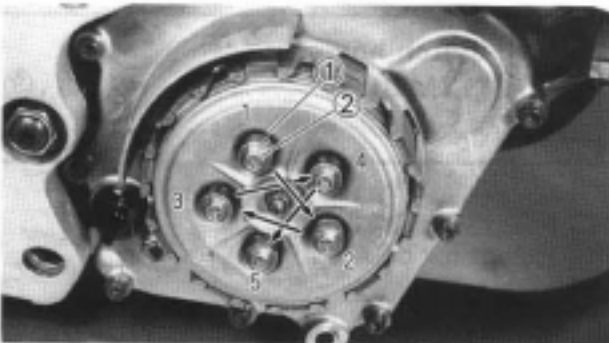

10. Install:
- Clutch spring ①
 - Screw (clutch spring) ②

NOTE:

Tighten the screws in stages, using a crisscross pattern.



Screw (clutch spring):
6 Nm (0.6 m • kg, 4.3 ft • lb)

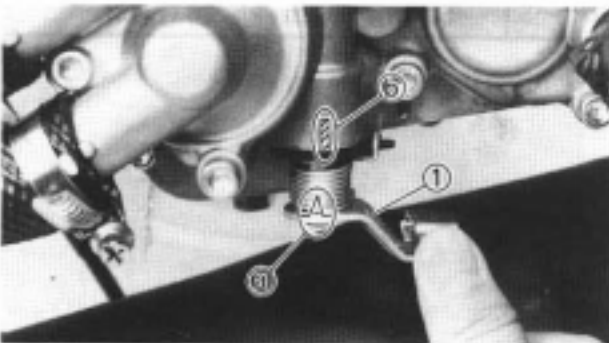

11. Check:
- Push lever position
- Push the push lever ① forward until it stops. With the push lever in this position, the projection (a) of the push lever should be aligned with the mating mark (b) on the crankcase.
- Not aligned → Adjust.

4

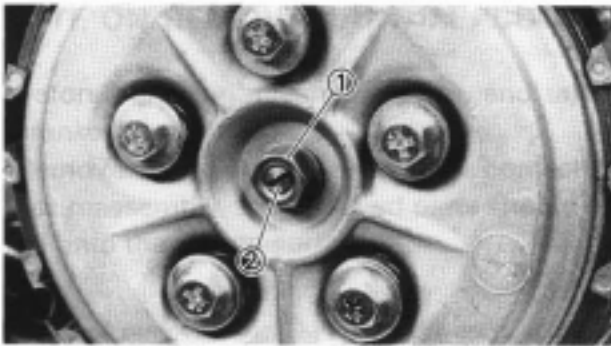

12. Adjust:
- Push lever position

Push lever position adjustment steps:

- Loosen the locknut ①.
- Turn the adjuster ② to align the projection of the push lever with the mating mark on the crankcase.
- Tighten the locknut.



Locknut:

6 Nm (0.6 m•kg, 4.3 ft•lb)



PRIMARY DRIVE GEAR, PRIMARY DRIVEN GEAR
AND BALANCER SHAFT
PREPARATION FOR REMOVAL



*Remove the following parts.

- Lower cowl
- Exhaust pipe
- Clutch
- Rotor

*Drain the transmission oil.

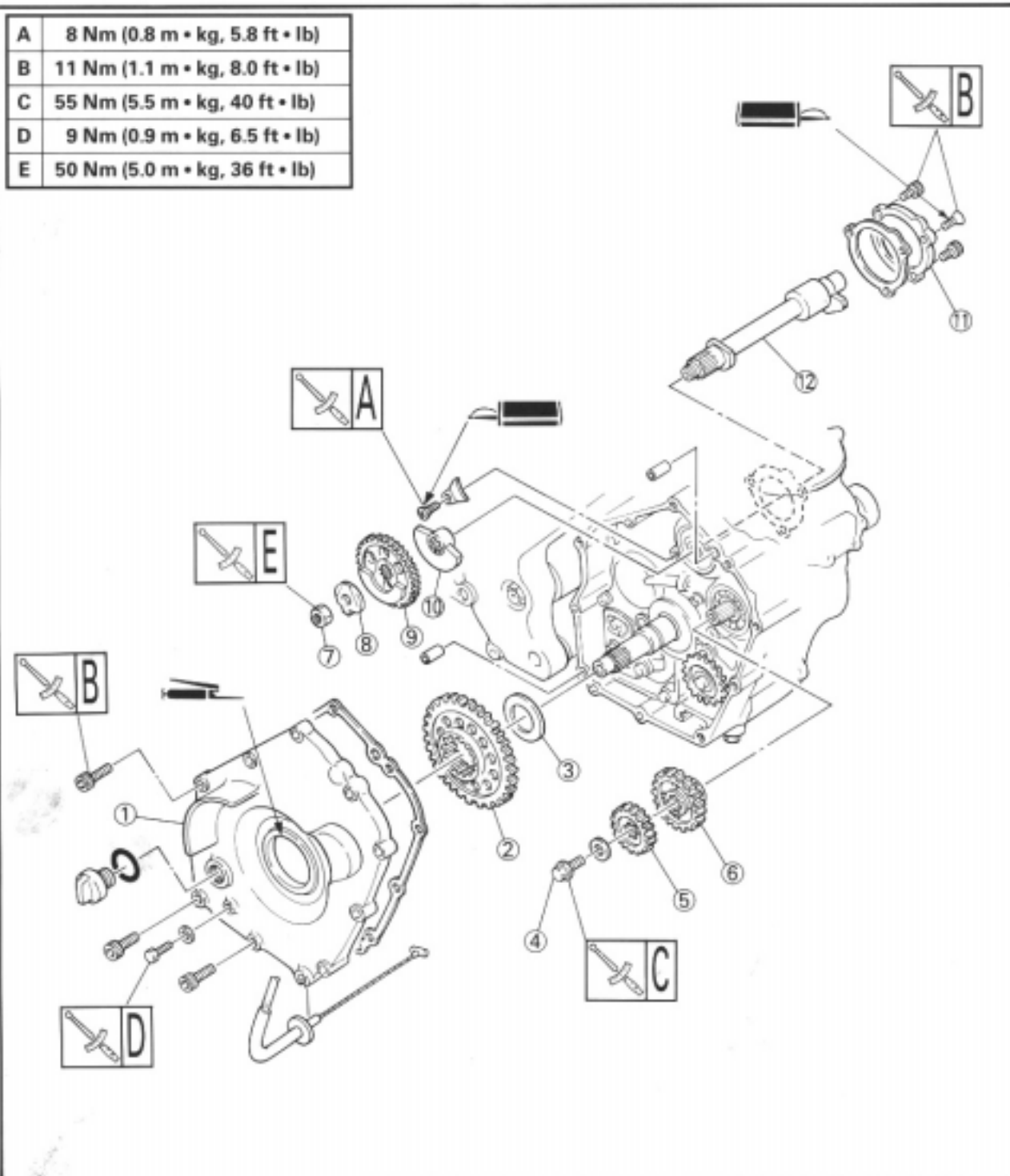



NOTE ON REMOVAL AND REASSEMBLY

- Before servicing, clean the parts, and take care so that foreign material does not enter the crankcase.
- Remove any gasket adhered to the contacting surfaces.
- For reassembly, the removed parts should be cleaned with solvent, and apply the transmission oil onto the sliding surface.

Extent of removal: ① Primary driven gear removal ② Primary drive gear removal
③ Balancer shaft removal

Extent of removal	Order	Part name	Q'ty	Remarks
	1	Crankcase cover (right)	1	
	2	Primary driven gear	1	
	3	Thrust plate	1	
	4	Bolt (primary drive gear)	1	
	5	Primary drive gear	1	
	6	Balancer drive gear	1	Refer to "REMOVAL POINTS".
	7	Nut (balancer weight gear)	1	
	8	Lock washer	1	
	9	Balancer weight gear	1	
	10	Weight	1	
	11	Crankcase cover (left)	1	Refer to "REMOVAL POINTS".
	12	Balancer shaft	1	

4

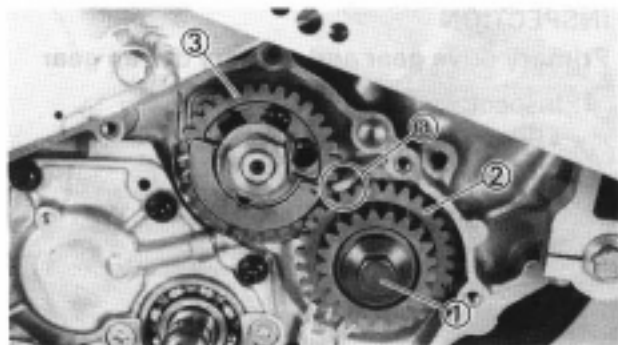

REMOVAL POINTS

Primary drive gear and balancer weight gear

1. Loosen:

- Bolt (primary drive gear) ①

NOTE:

Place an aluminum plate (a) between the teeth of the balancer drive gear ② and balancer weight gear ③.



2. Loosen:

- Nut (balancer weight gear) ①

NOTE:

Straighten the lock washer ② tab and place an aluminum plate (a) between the teeth of the balancer drive gear ③ and balancer weight gear ④.



3. Remove:

- Bolt (primary drive gear) ①
- Primary drive gear ②
- Balancer drive gear ③
- Nut (balancer weight gear) ④
- Lock washer ⑤
- Balancer weight gear ⑥

NOTE:

It may sometimes happens that the primary drive gear and balancer drive gear are fitted too tight as in force fitting. In that case, use a general gear puller to remove them without too much force on the crankshaft.

4

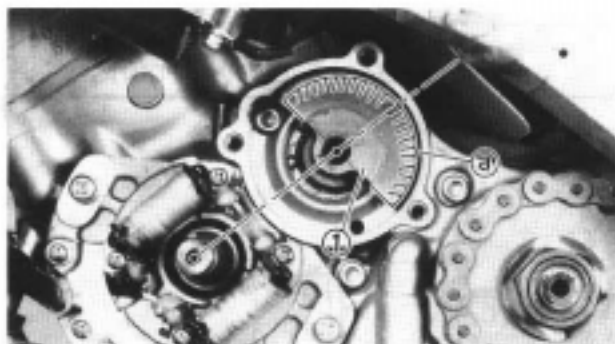

Balancer shaft

1. Remove:

- Balancer shaft ①

NOTE:

When removing the balancer shaft, align the center of the balancer shaft weight (a) along the line connecting the centers of the crankshaft and balancer shaft.

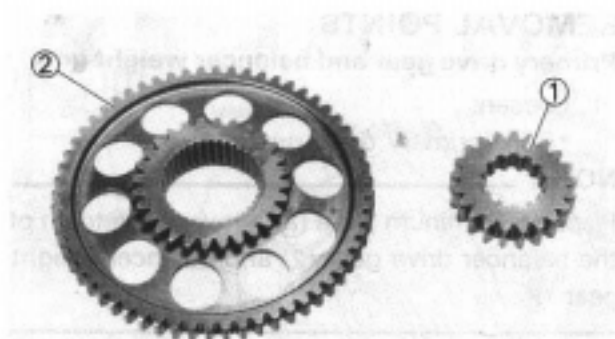

INSPECTION

Primary drive gear and primary driven gear

1. Inspect:

- Primary drive gear ①
 - Primary driven gear ②
- Wear/Damage → Replace.

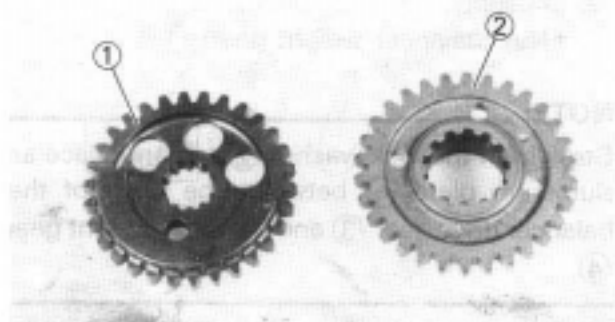

Balancer weight gear and balancer drive gear

1. Inspect:

- Balancer weight gear ①
 - Balancer drive gear ②
- Wear/Damage → Replace.

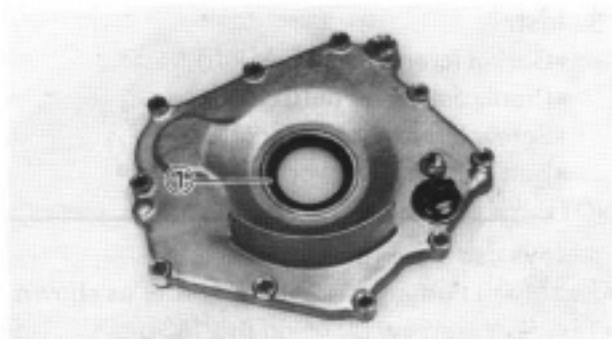

Crankcase cover (right)

1. Inspect:
 - Contacting surface
Scratches→Replace.
 - Crankcase cover (right)
Cracks/Damage→Replace.
 - Oil seal ①
Wear/Damage→Replace.

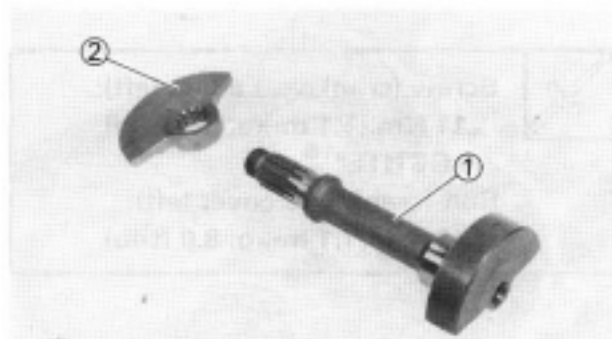

Balancer shaft

1. Inspect:
 - Balancer shaft ①
Bend/Wear/Damage→Replace.
 - Weight ②
Damage→Replace.

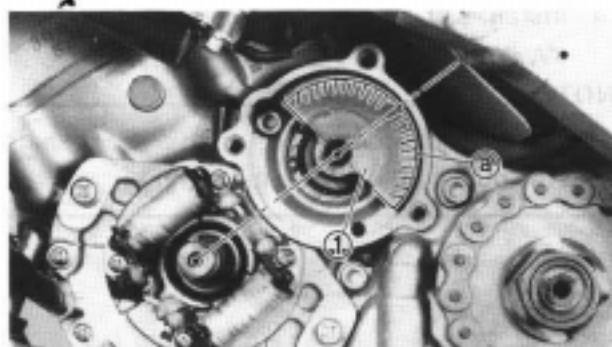

ASSEMBLY AND INSTALLATION

Balancer shaft and primary drive gear

1. Install:
 - Balancer shaft ①

NOTE:

When installing the balancer shaft, align the center of the balancer shaft weight (a) along the line connecting the centers of the crankshaft and balancer shaft.

4

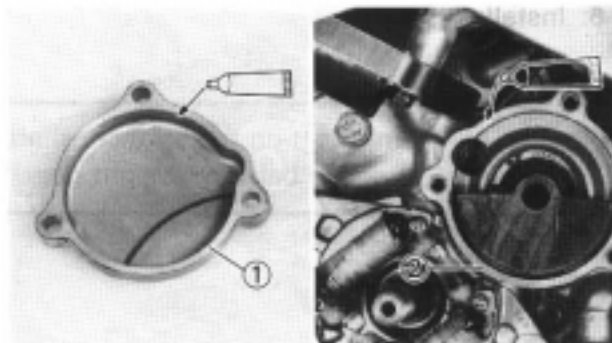

2. Apply:

- Sealant
Onto the crankcase cover (left) ① and
crankcase (left) ②.

NOTE:

- Clean the contacting surface of the
crankcase (left) and crankcase cover (left)
before applying the sealant.
- Completely remove the extra sealant that
comes out on the inside.



Quick gasket*:
ACC-11001-05-01
Yamaha bond No. 1215:
90890-85505

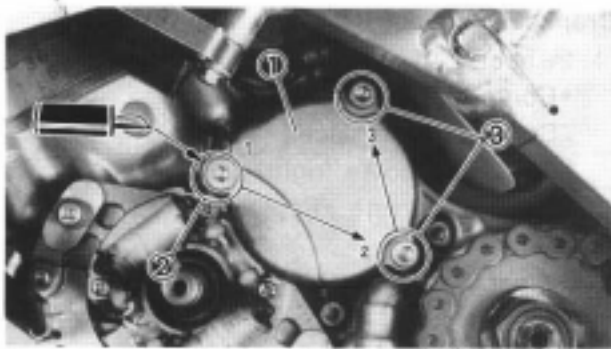

3. Install:

- Gasket (crankcase cover left)
- Crankcase cover (left) ①
- Screw (crankcase cover left) ②
- Bolt (crankcase cover left) ③

NOTE:

- Always use a new gasket.
- Be sure to tighten in numbered order as shown.
- Tighten the screw ② using the T30 bit.



Screw (crankcase cover left):
11 Nm (1.1 m·kg, 8.0 ft·lb)
LOCTITE®
Bolt (crankcase cover left):
11 Nm (1.1 m·kg, 8.0 ft·lb)

4

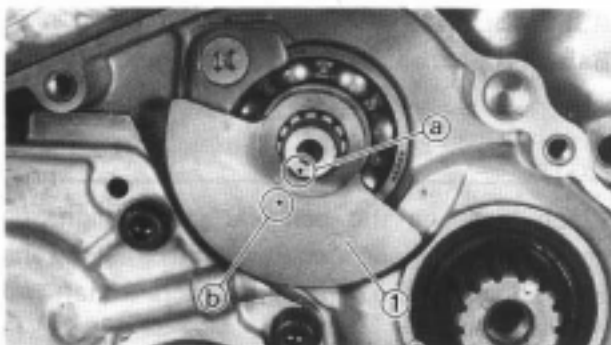

4. Install:

- Weight ①

NOTE:

Align the punch mark ① on the balancer shaft with the punch mark ② on the weight.

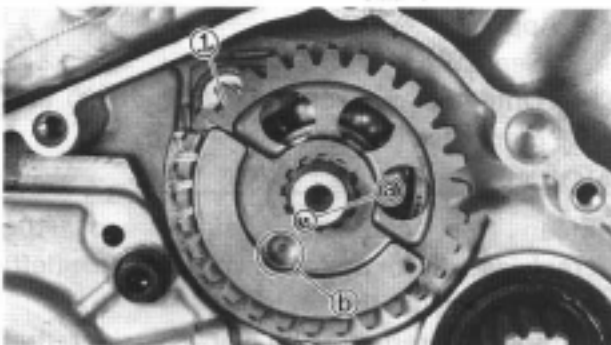

5. Install:

- Balancer weight gear ①

NOTE:

Align the punch mark ① on the balancer shaft with the hole ② of the balancer weight gear.



6. Install:

- Balancer drive gear ①

NOTE:

Align the punch marks, ① (balancer drive gear) with ② (crankshaft) and ③ (balancer drive gear) with ④ (balancer weight gear) as shown.

PRIMARY DRIVE GEAR, PRIMARY DRIVEN GEAR AND BALANCER SHAFT

ENG

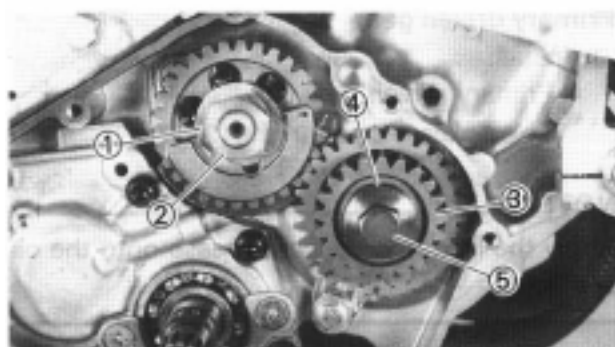

7. Install:

- Lock washer ①
- Nut (balancer weight gear) ②
- Primary drive gear ③
- Plain washer ④
- Bolt (primary drive gear) ⑤

NOTE:

Always use a new lock washer.



8. Tighten:

- Nut (balancer weight gear) ①



Nut (balancer weight gear):
50 Nm (5.0 m•kg, 36 ft•lb)

NOTE:

Place an aluminum plate ① between the teeth of the balancer drive gear ② and balancer weight gear ③.

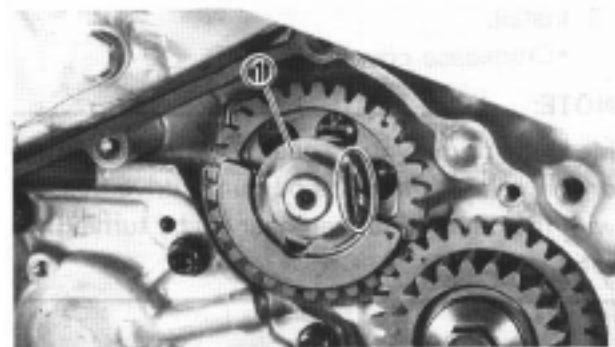

9. Bend the lock washer ① tab.

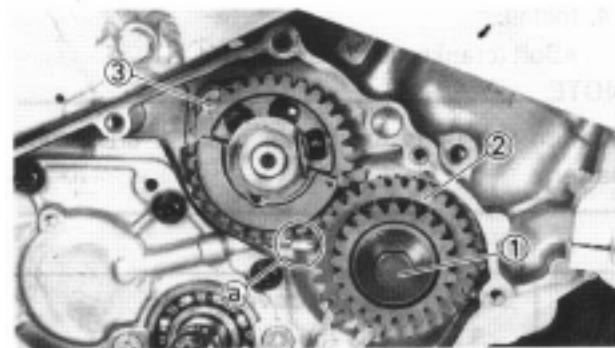

10. Tighten:

- Bolt (primary drive gear) ①



Bolt (primary drive gear):
55 Nm (5.5 m•kg, 40 ft•lb)

NOTE:

Place an aluminum plate ① between the teeth of the balancer drive gear ② and balancer weight gear ③.

4

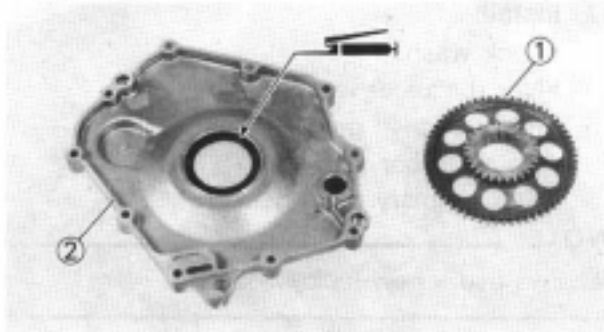

Primary driven gear

1. Install:
 - Primary driven gear (1)
 - To crankcase cover (right) (2).

NOTE: _____

Apply the lithium soap base grease onto the oil seal lip.

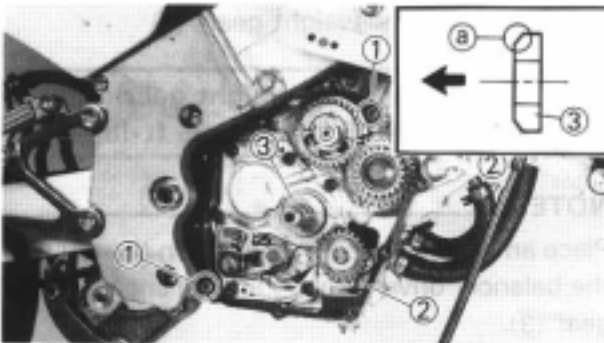

2. Install:
 - Dowel pin (1)
 - Gasket (crankcase cover right) (2)
 - Thrust plate (3)

NOTE: _____

- Always use a new gasket.
- Install the thrust plate with its chamfered portion (a) toward the transmission.

4

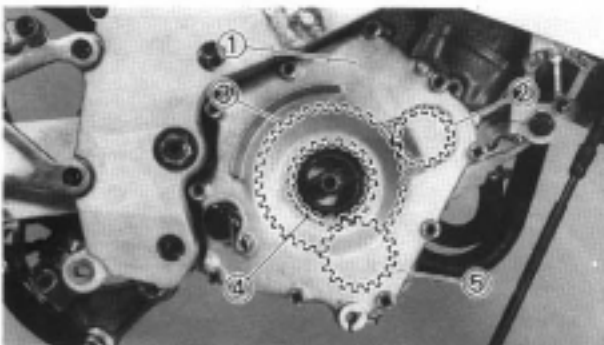

3. Install:
 - Crankcase cover (right) (1)

NOTE: _____

Mesh the primary drive gear (2) with the primary driven gear (3), and the oil pump drive gear (4) with the oil pump driven gear (5) by turning the rotor.

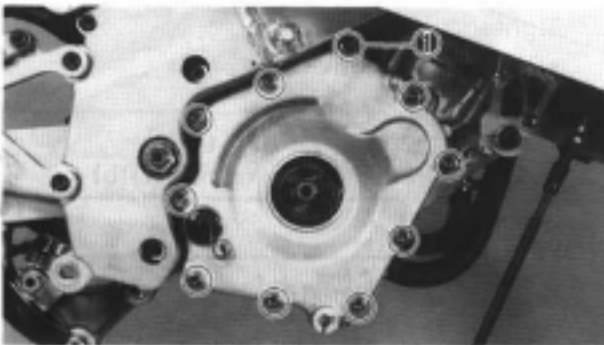

4. Install:
 - Bolt (crankcase cover right) (1)

NOTE: _____

Tighten the bolts in stages, using a crisscross pattern.



Bolt (crankcase cover right):
11 Nm (1.1 m•kg, 8.0 ft•lb)



SHIFT SHAFT AND OIL PUMP

PREPARATION FOR REMOVAL



* Remove the following parts.

- Lower cowl
- Exhaust pipe
- Clutch

* Drain the transmission oil.

* Remove the crankcase cover (right).

TIP CLEARANCE LIMIT:
0.15 mm (0.0059 in)

A 12 Nm (1.2 m·kg, 8.7 ft·lb)

B 11 Nm (1.1 m·kg, 8.0 ft·lb)

C 9 Nm (0.9 m·kg, 6.5 ft·lb)

D 14 Nm (1.4 m·kg, 10 ft·lb)

E 4 Nm (0.4 m·kg, 2.9 ft·lb)

F 7 Nm (0.7 m·kg, 5.1 ft·lb)

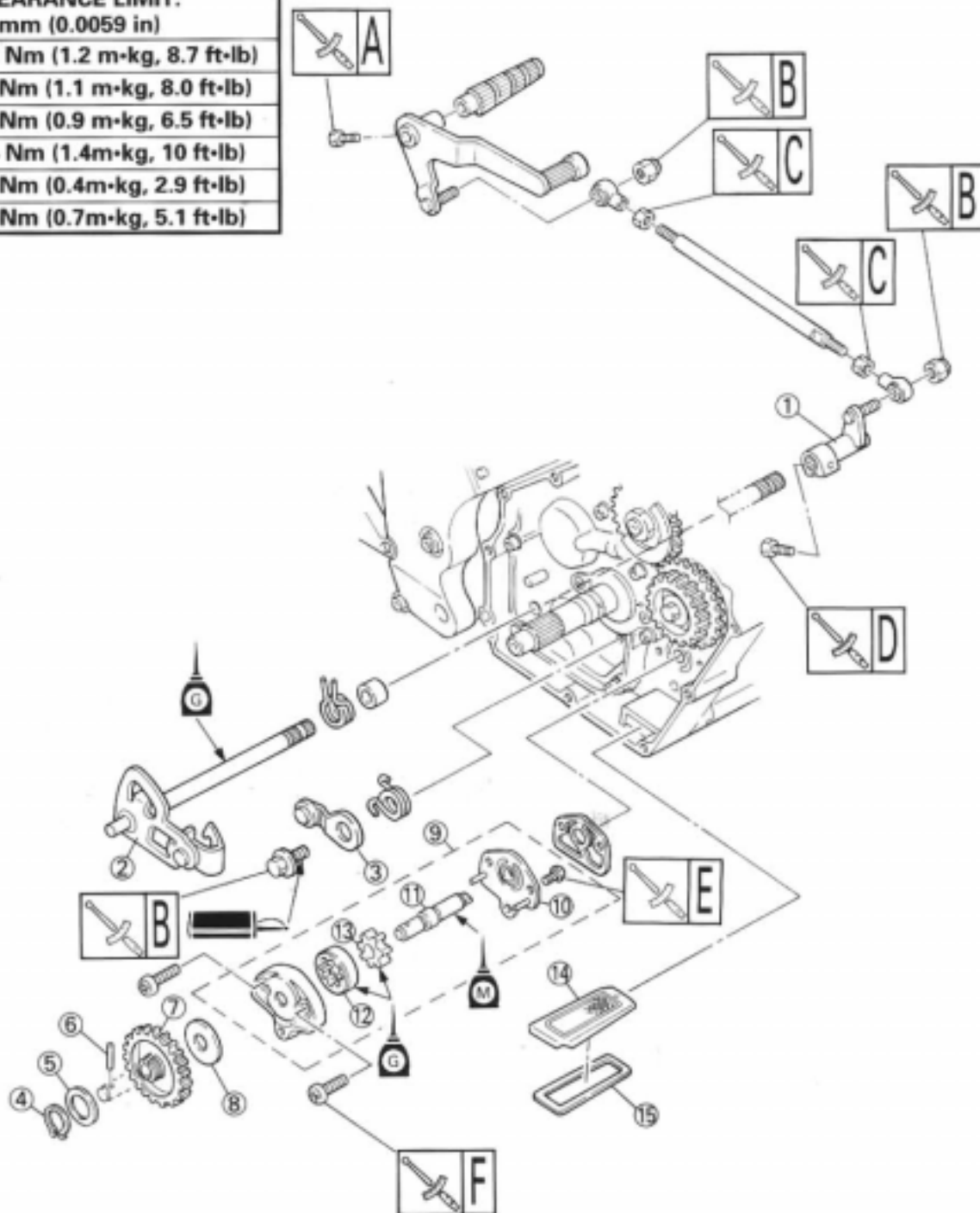



NOTE ON REMOVAL AND REASSEMBLY

- Before servicing, clean the parts, and take care so that foreign material does not enter the crankcase.
- Remove any gasket adhered to the contacting surfaces.
- For reassembly, the removed parts should be cleaned with solvent, and apply the transmission oil onto the sliding surfaces.

Extent of removal:

- ① Shift shaft and stopper lever removal
- ② Oil pump removal and disassembly
- ③ Strainer removal

Extent of removal	Order	Part name	Q'ty	Remarks
	1	Shift arm	1	
	2	Shift shaft	1	
	3	Stopper lever	1	
	4	Circlip	1	
	5	Plate washer	1	
	6	Dowel pin	1	
	7	Oil pump driven gear	1	
	8	Shim	1	
	9	Oil pump assembly	1	
	10	Oil pump cover	1	
	11	Oil pump shaft	1	
	12	Outer rotor	1	
	13	Inner rotor	1	
	14	Strainer 1	1	
	15	Strainer 2	1	

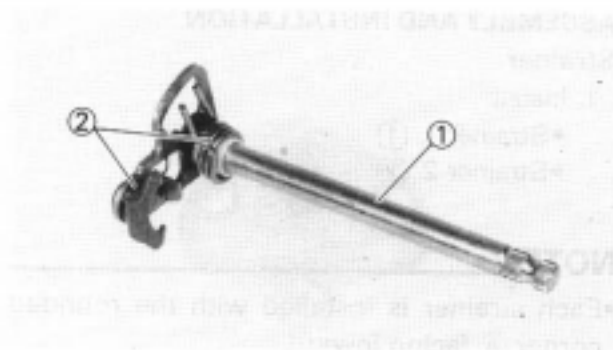
4

INSPECTION

Shift shaft

1. Inspect:
 - Shift shaft ①
Bend/Damage → Replace.
 - Spring ②
Broken → Replace.

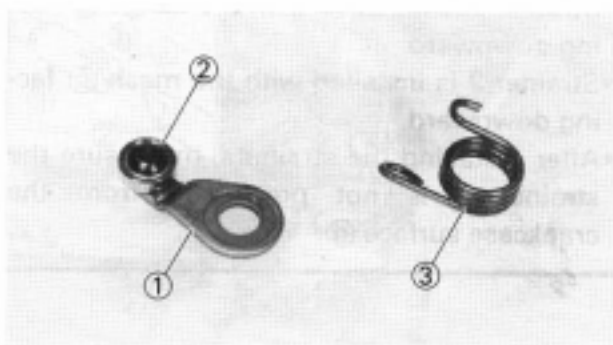

Stopper lever

1. Inspect:
 - Stopper lever ①
Wear/Damage → Replace.
 - Bearing ②.
Rotate outer race with a finger.
Rough spot/Seizure → Replace the stopper lever.
 - Torsion spring ③
Broken → Replace.

**Oil pump**

1. Measure:

- Tip clearance

Measure the clearance between the inner rotor ① and outer rotor ②.

Out of limit → Replace the inner rotor and outer rotor as a set.



Tip clearance limit:
0.15 mm (0.0059 in)

2. Inspect:

- Oil pump driven gear ①
- Oil pump shaft ②

Wear/Damage → Replace.

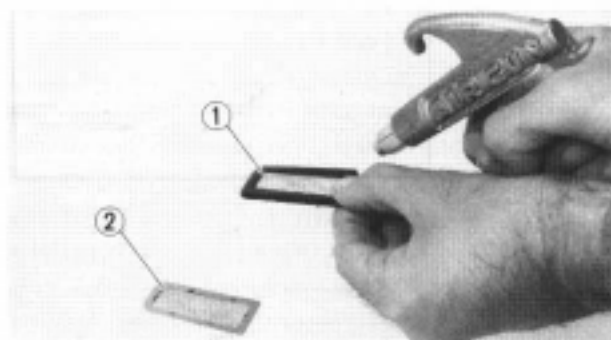
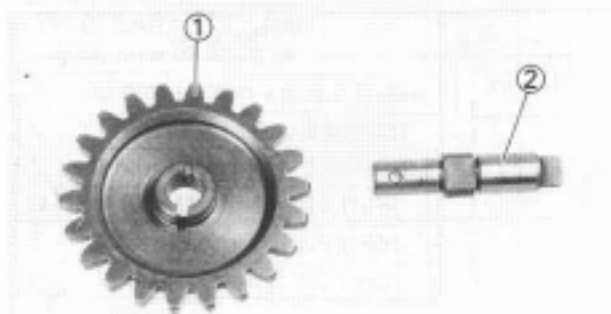
**Strainer**

1. Clean:

- Strainer 1 ①
- Strainer 2 ②

Use compressed air.

NOTE:

- Clean the strainer every 500 km.
- If a lot of metallic dust is noticed, disassemble the engine and check.

ASSEMBLY AND INSTALLATION**Strainer**

1. Install:

- Strainer 1 ①
- Strainer 2 ②

NOTE:

- Each strainer is installed with the rounded corner (a) facing inward.
- Strainer 1 is installed with the flange (b) facing downward.
- Strainer 2 is installed with the mesh (c) facing downward.
- After installing the strainers, make sure the strainer 2 is not protruding from the crankcase surface (d).

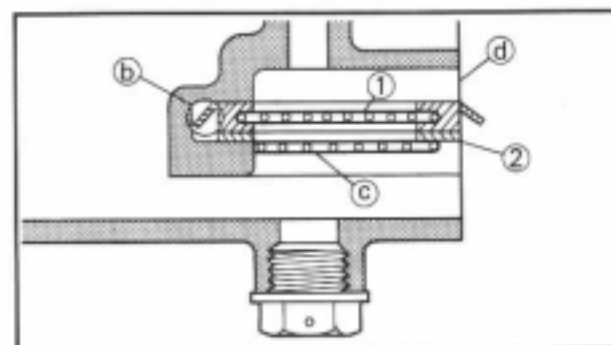
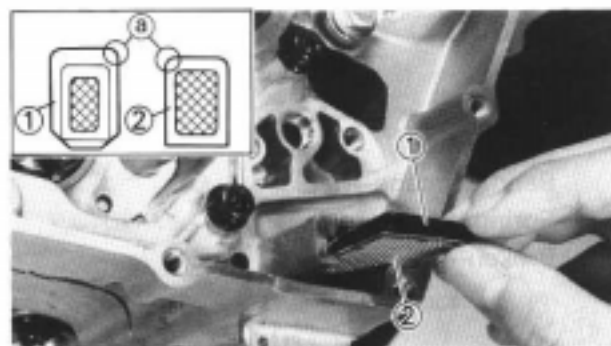

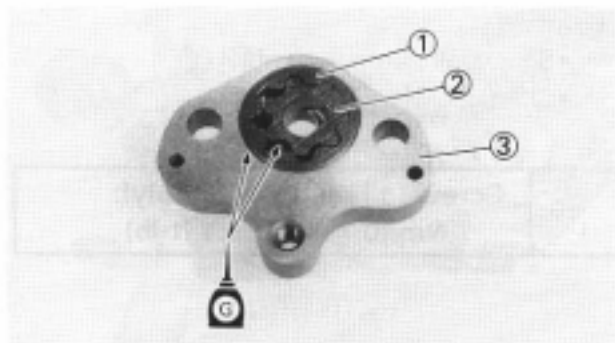
**Oil pump**

1. Install:

- Outer rotor ①
 - Inner rotor ②
- To oil pump housing ③.

NOTE: _____

Apply the transmission oil onto the inner rotor and outer rotor.

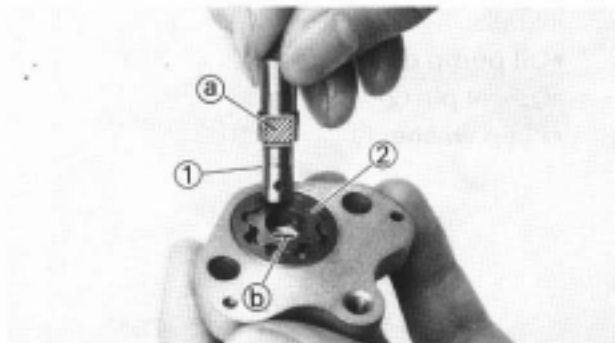

2. Install:

- Oil pump shaft ①
- To inner rotor ②.

NOTE: _____

Install the oil pump shaft with its flat portion (a) placed on the flat portion (b) of the inner rotor.

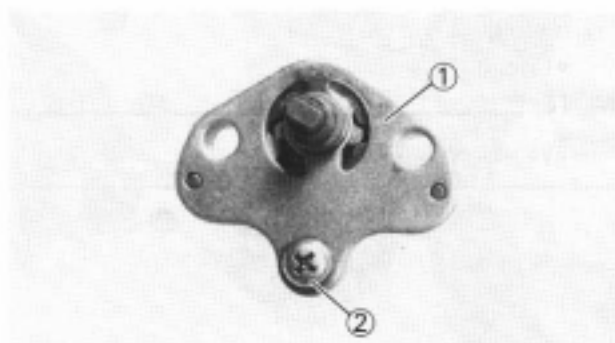

3. Install:

- Oil pump cover ①
- Screw (oil pump cover) ②



Screw (oil pump cover):
4 Nm (0.4 m • kg, 2.9 ft • lb)

4

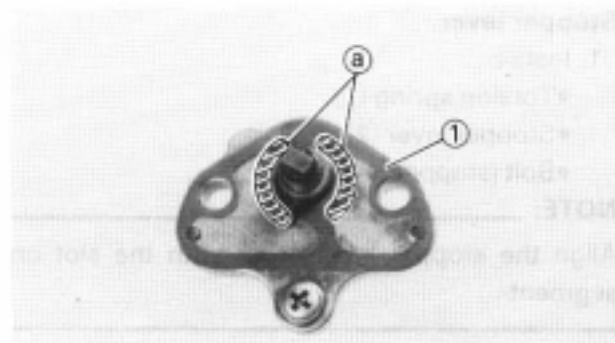

4. Install:

- Gasket (oil pump) ①

NOTE: _____

- Always use a new gasket.
- Install the gasket in accordance with the shapes of the oil passages (a).

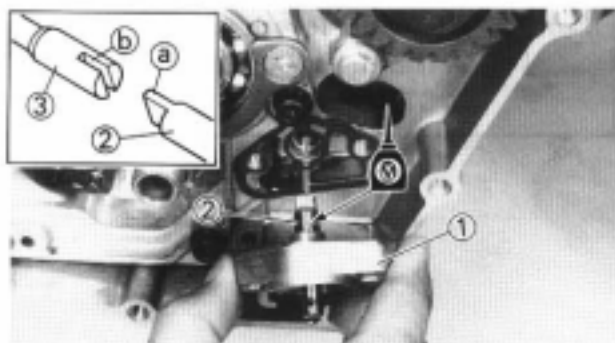

5. Install:

- Oil pump assembly ①

NOTE: _____

- Apply the molybdenum disulfide oil onto the oil pump shaft ②.
- When installing the oil pump assembly, turn the oil pump shaft until its key end (a) is in the recess (b) of the impeller shaft ③.

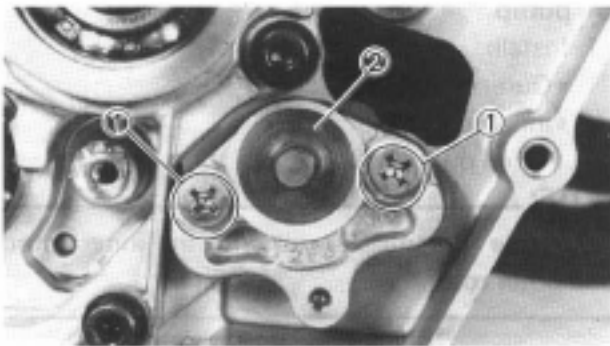

6. Install:

- Screw (oil pump assembly) ①
- Shim ②



Screw (oil pump assembly):
7 Nm (0.7 m•kg, 5.1 ft•lb)

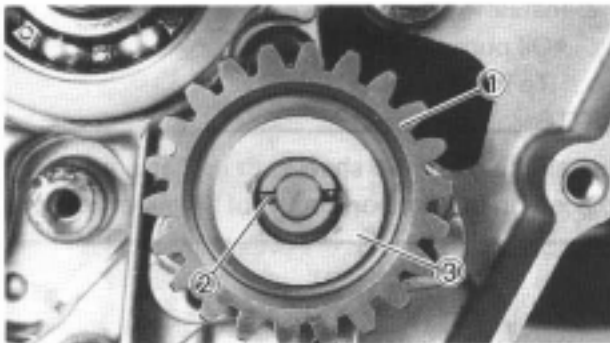

7. Install:

- Oil pump driven gear ①
- Dowel pin ②
- Plain washer ③

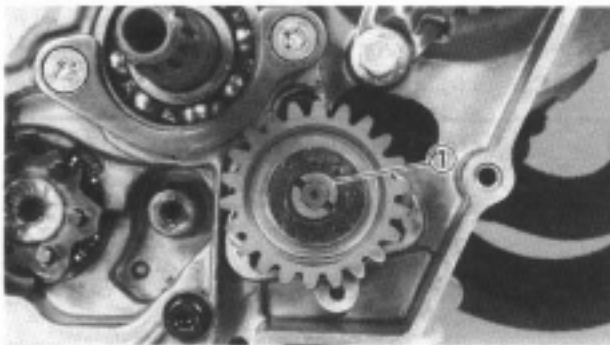

8. Install:

- Circlip ①

NOTE: _____

Always use a new circlip.

4

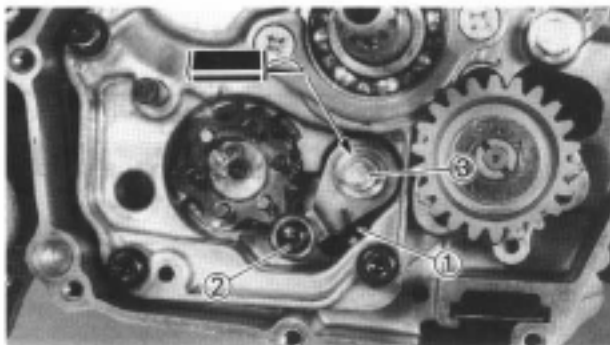

Stopper lever

1. Install:

- Torsion spring ①
- Stopper lever ②
- Bolt (stopper lever) ③

NOTE: _____

Align the stopper lever roller with the slot on segment.

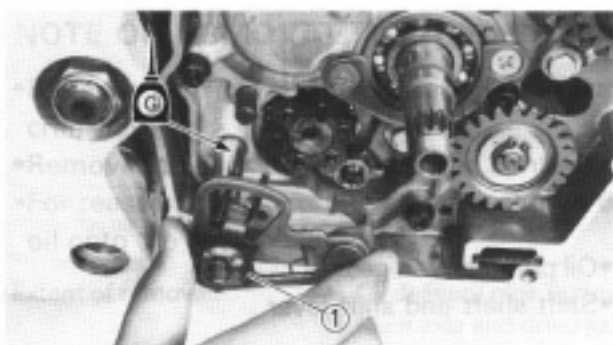

Bolt (stopper lever):
11 Nm (1.1 m•kg, 8.0 ft•lb)
LOCTITE®

**Shift shaft**

1. Install:

- Shift shaft ①

NOTE: _____

Apply the transmission oil onto the shift shaft.

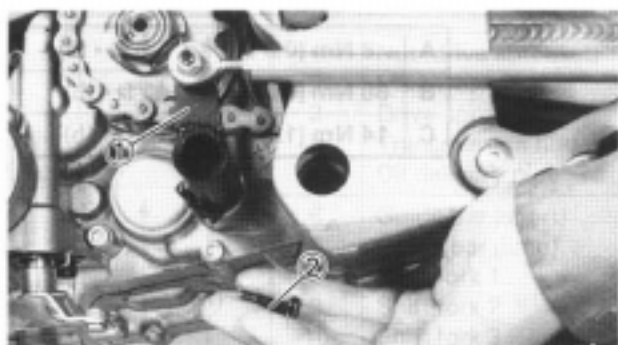

2. Install:

- Shift arm ①
- Bolt (shift arm) ②

NOTE: _____

- Make sure that the joint rod distance (a) is 269~271 mm (10.6~10.7 in).
- Install the shift arm so that the top of the shift pedal outer diameter (b) is highest without exceeding the bottom end (c) of the footrest bracket.

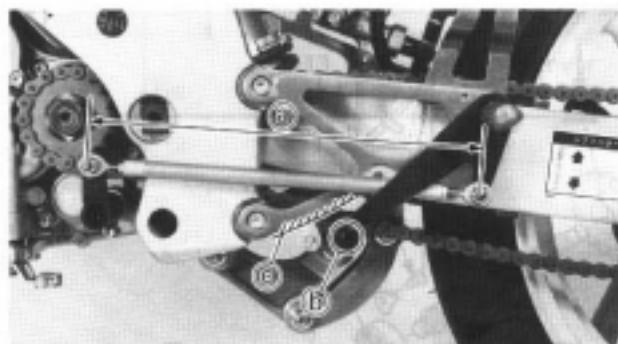
**Bolt (shift arm):****14 Nm (1.4 m·kg, 10 ft·lb)****4**



TRANSMISSION, SHIFT CAM AND SHIFT FORK PREPARATION FOR REMOVAL



- * Remove the lower cowl.
- * Remove the exhaust pipe.
- * Drain the transmission oil.
- * Remove the following parts:
 - Clutch
 - Crankcase cover (right)

- Oil pump driven gear
- Shift shaft and shift lever

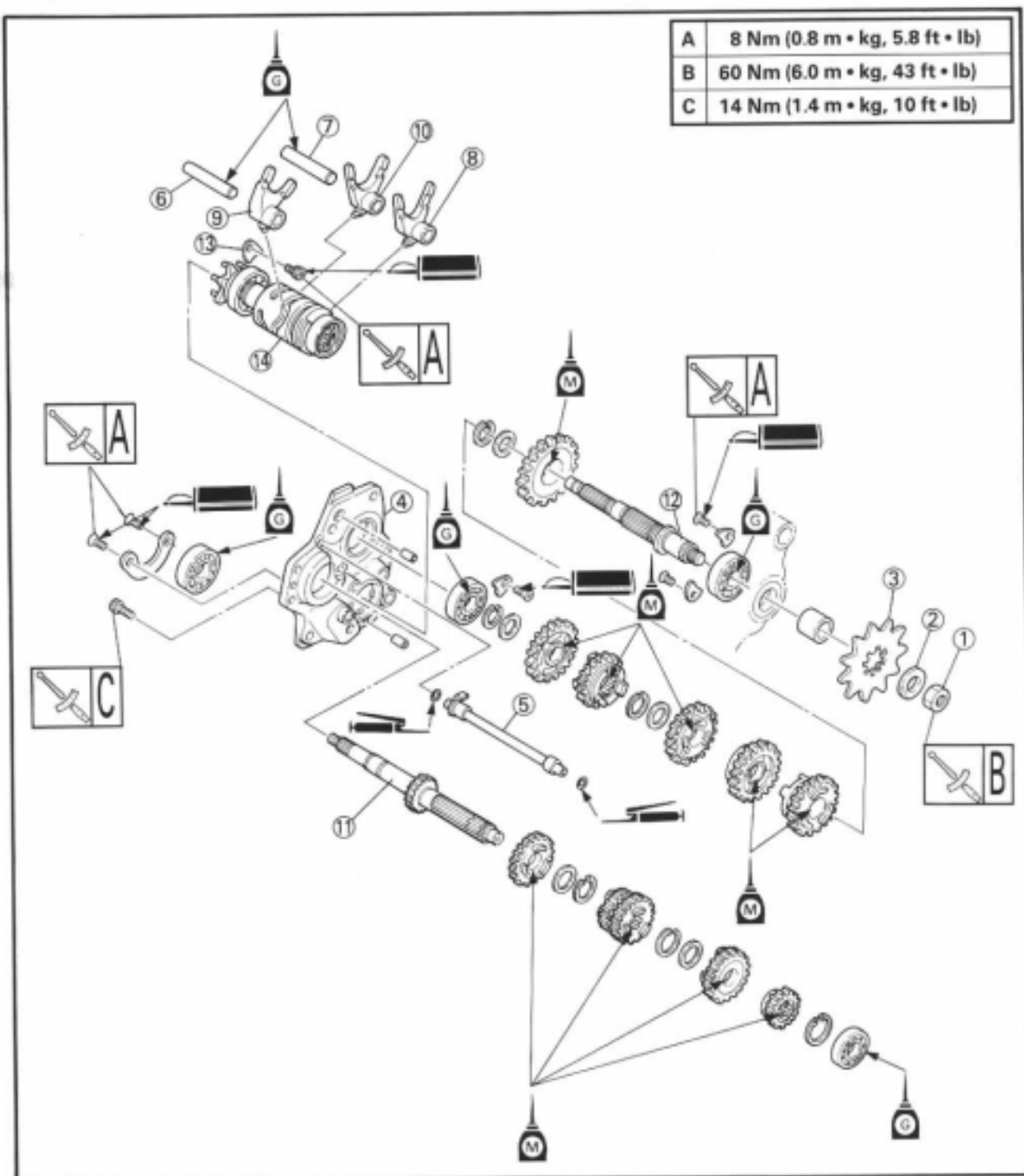

4



NOTE ON REMOVAL AND REASSEMBLY

- Before servicing, clean the parts, and take care so that foreign material does not enter the crankcase.
- Remove the gasket adhered to the contacting surface.
- For reassembly, the removed parts should be cleaned with solvent, and apply the transmission oil onto the sliding surface.

Extent of removal: ① Oil delivery pipe removal ② Shift cam and shift fork removal
 ③ Main axle and drive axle removal

Extent of removal	Order	Part name	Q'ty	Remarks
	1	Nut (drive sprocket)	1	} Refer to "REMOVAL POINTS".
	2	Lock washer	1	
	3	Drive sprocket	1	
	4	Transmission housing	1	} Refer to "REMOVAL POINTS".
	5	Oil delivery pipe	1	
	6	Guide bar (short)	1	
	7	Guide bar (long)	1	
	8	Shift fork 1	1	
	9	Shift fork 2	1	
	10	Shift fork 3	1	
	11	Main axle	1	} Refer to "REMOVAL POINTS".
	12	Drive axle	1	
	13	Bearing plate cover	2	} Refer to "REMOVAL POINTS".
	14	Shift cam	1	

4

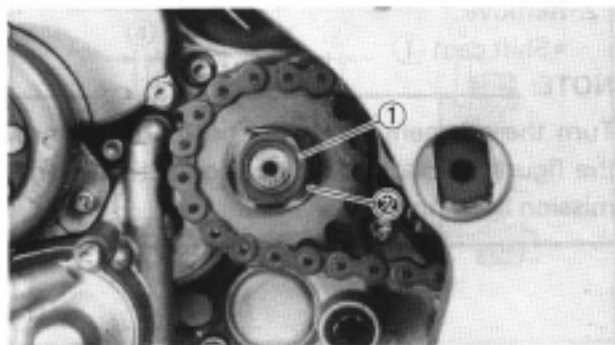

REMOVAL POINTS

Drive sprocket

1. Straighten the lock washer tab.
2. Remove:
 - Nut (drive sprocket) ①
 - Lock washer ②

NOTE: _____
 Loosen the nut while applying the rear brake.

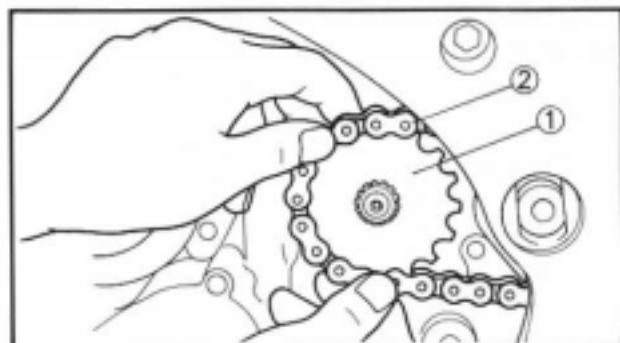

3. Remove:
 - Drive sprocket ①
- NOTE:** _____
 Remove the drive sprocket together with the drive chain ②.

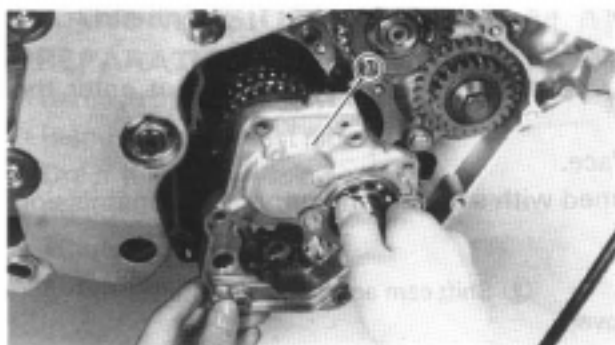

Transmission housing

1. Remove:
 - Bolt (transmission housing)
 - Transmission housing ①

NOTE: _____
 Remove the transmission housing together with the transmission, shift cam and shift fork.

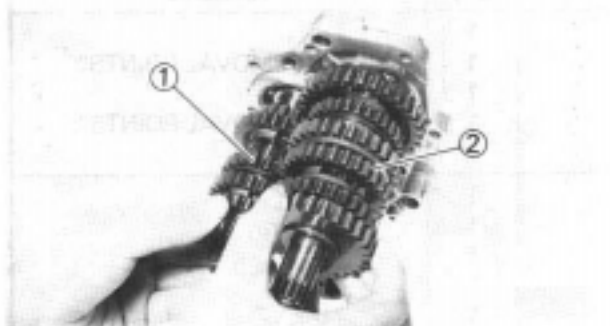

Transmission

1. Remove:
 - Main axle ①
 - Drive axle ②

NOTE: _____
 • Remove the main axle together with the drive axle from the transmission housing ③.
 • Remove assembly carefully. Note the position of each part. Pay particular attention to the location and direction of shift forks.

4

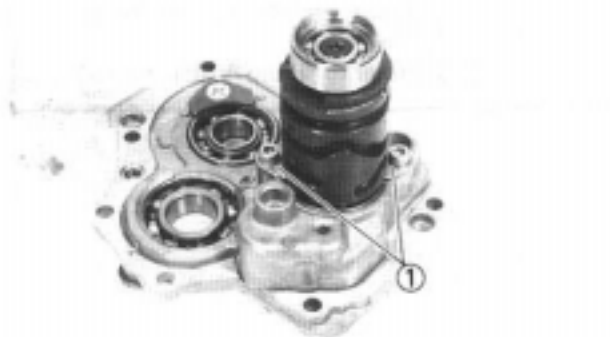

Shift cam

1. Remove:
 - Bearing plate cover ①

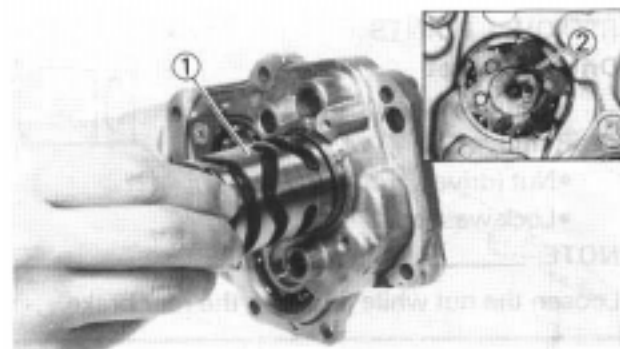

2. Remove:
 - Shift cam ①

NOTE: _____
 Turn the segment ② to the position shown in the figure so that it does not contact the transmission housing.

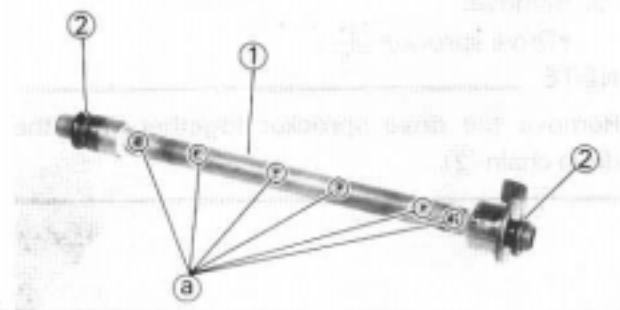

INSPECTION

Oil delivery pipe

1. Inspect:
 - Oil delivery pipe ①
 - O-ring ②
Damage—Replace.
 - Oil orifice (a)
Clogged—Blow.

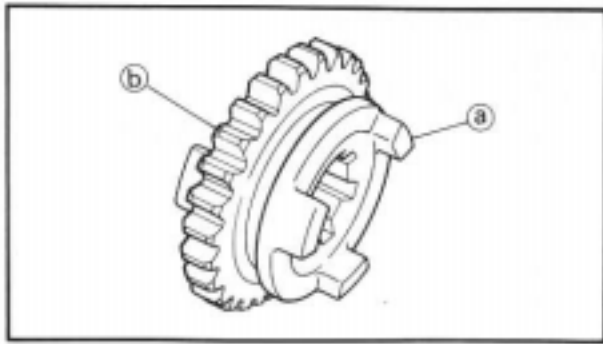

Gears

1. Inspect:

- Matching dog (a)
 - Gear teeth (b)
- Wear/Damage → Replace.

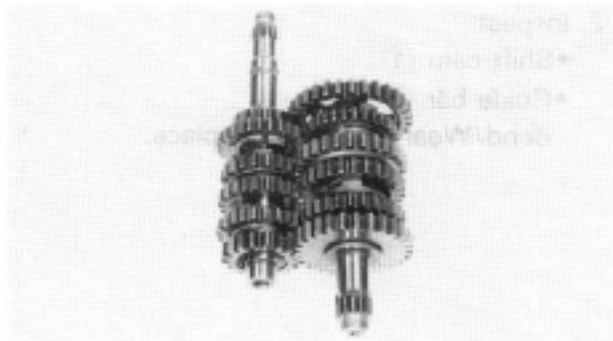

2. Check:

- Gears movement
- Unsmooth movement → Repair or replace.

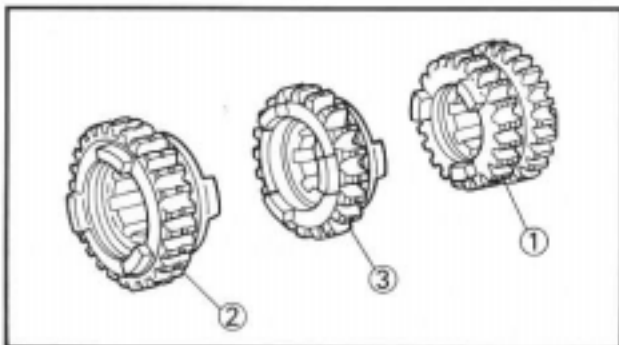

Shift fork groove

1. Measure:

- 3rd/4th pinion gear (1)
 - 5th wheel gear (2)
 - 6th wheel gear (3)
 - Shift fork groove (a)
- Out of specification → Replace.

4

Shift fork groove (a):	
Standard	< Limit >
5.05 – 5.18 mm (0.199 – 0.204 in)	5.35 mm (0.211 in)

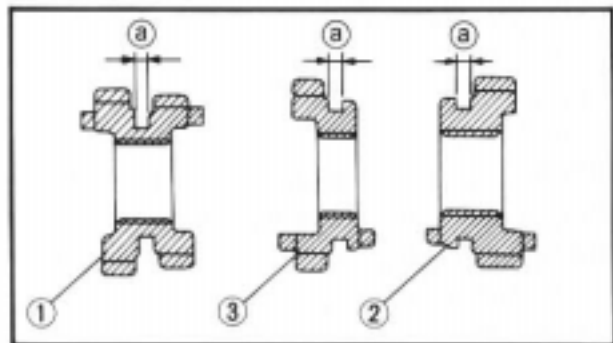

Bearing

1. Inspect:

- Bearing (1)
- Rotate inner race with a finger.
Rough spot/Seizure → Replace.

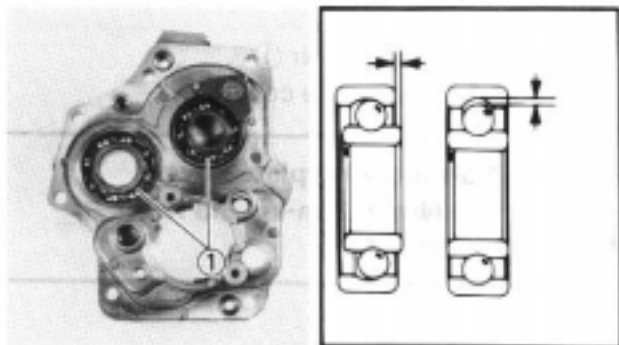

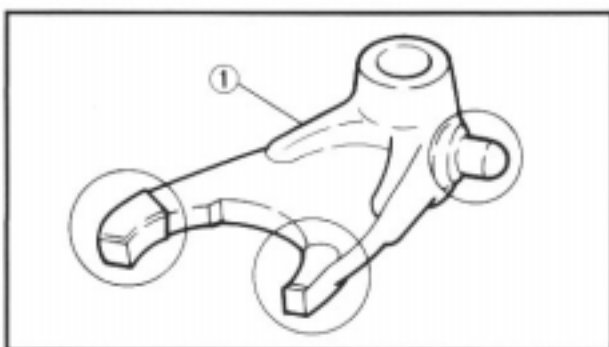

Shift fork and shift cam

1. Inspect:

- Shift fork ①
Wear/Damage/Scratches → Replace.

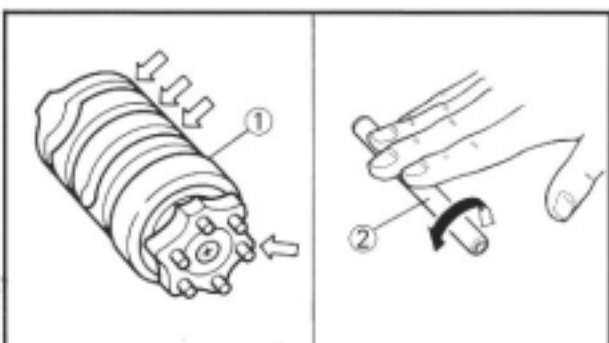

2. Inspect:

- Shift cam ①
- Guide bar ②
Bend/Wear/Damage → Replace.

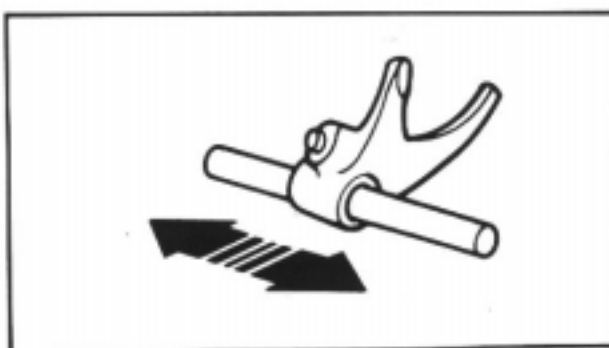

3. Check:

- Shift fork movement
On its guide bar.
Unsmooth operation → Replace.
Shift fork and/or guide bar.

4

NOTE:

For a malfunctioning shift fork, replace not only the shift fork itself but the two gears each adjacent to the shift fork.

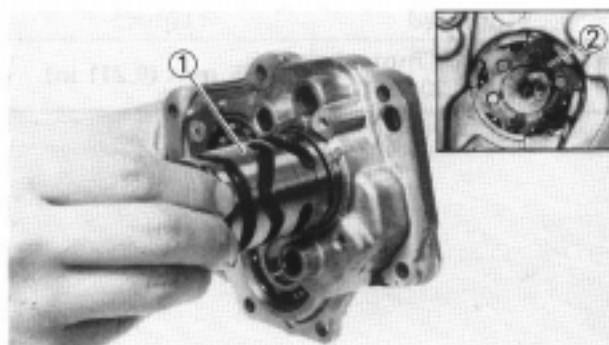

ASSEMBLY AND INSTALLATION

Shift cam

1. Install:

- Shift cam ①

NOTE:

Turn the segment ② to the position shown in the figure so that it does not contact the transmission housing.

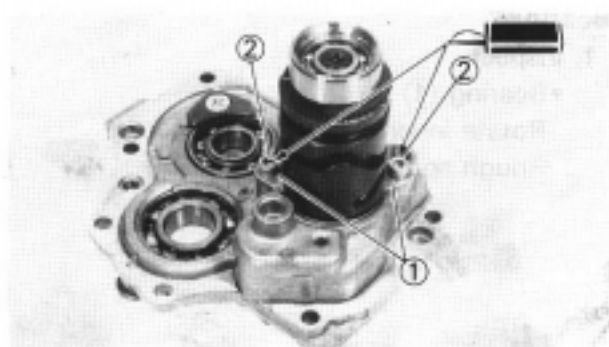

2. Install:

- Bearing plate cover ①
- Bolt (bearing plate cover) ②

	<p>Bolt (bearing plate cover): 8 Nm (0.8 m·kg, 5.8 ft·lb) LOCTITE®</p>
--	---

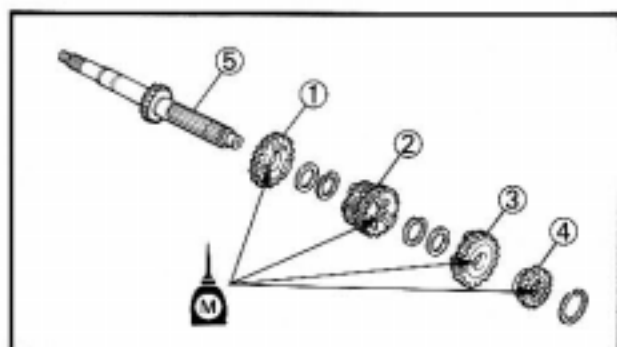
**Transmission**

1. Install:

- 6th pinion gear (27T) ①
 - 3rd/4th pinion gear (19/22T) ②
 - 5th pinion gear (23T) ③
 - 2nd pinion gear (17T) ④
- To main axle ⑤.

NOTE:

Apply the molybdenum disulfide oil onto the gears inner circumference.

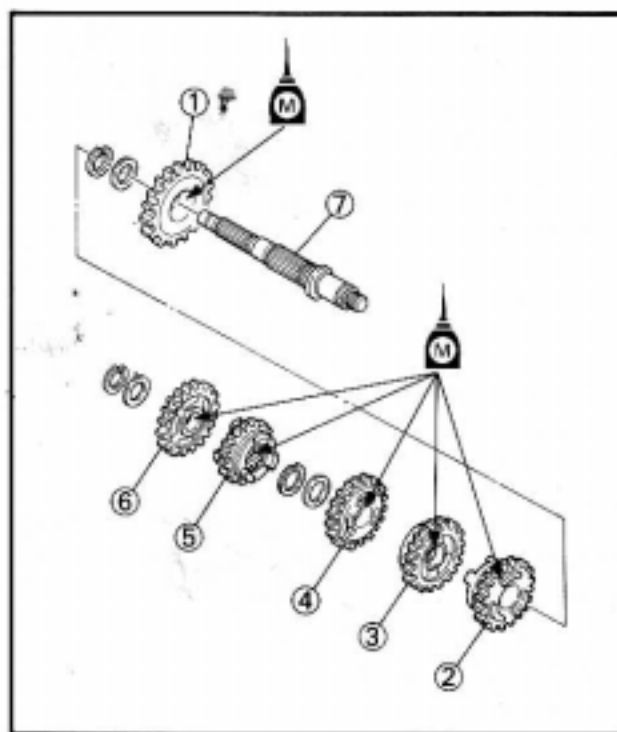

2. Install:

- 2nd wheel gear (27T) ①
 - 5th wheel gear (26T) ②
 - 4th wheel gear (27T) ③
 - 3rd wheel gear (26T) ④
 - 6th wheel gear (29T) ⑤
 - 1st wheel gear (30T) ⑥
- To drive axle ⑦.

NOTE:

Apply the molybdenum disulfide oil onto the gears inner circumference.

4

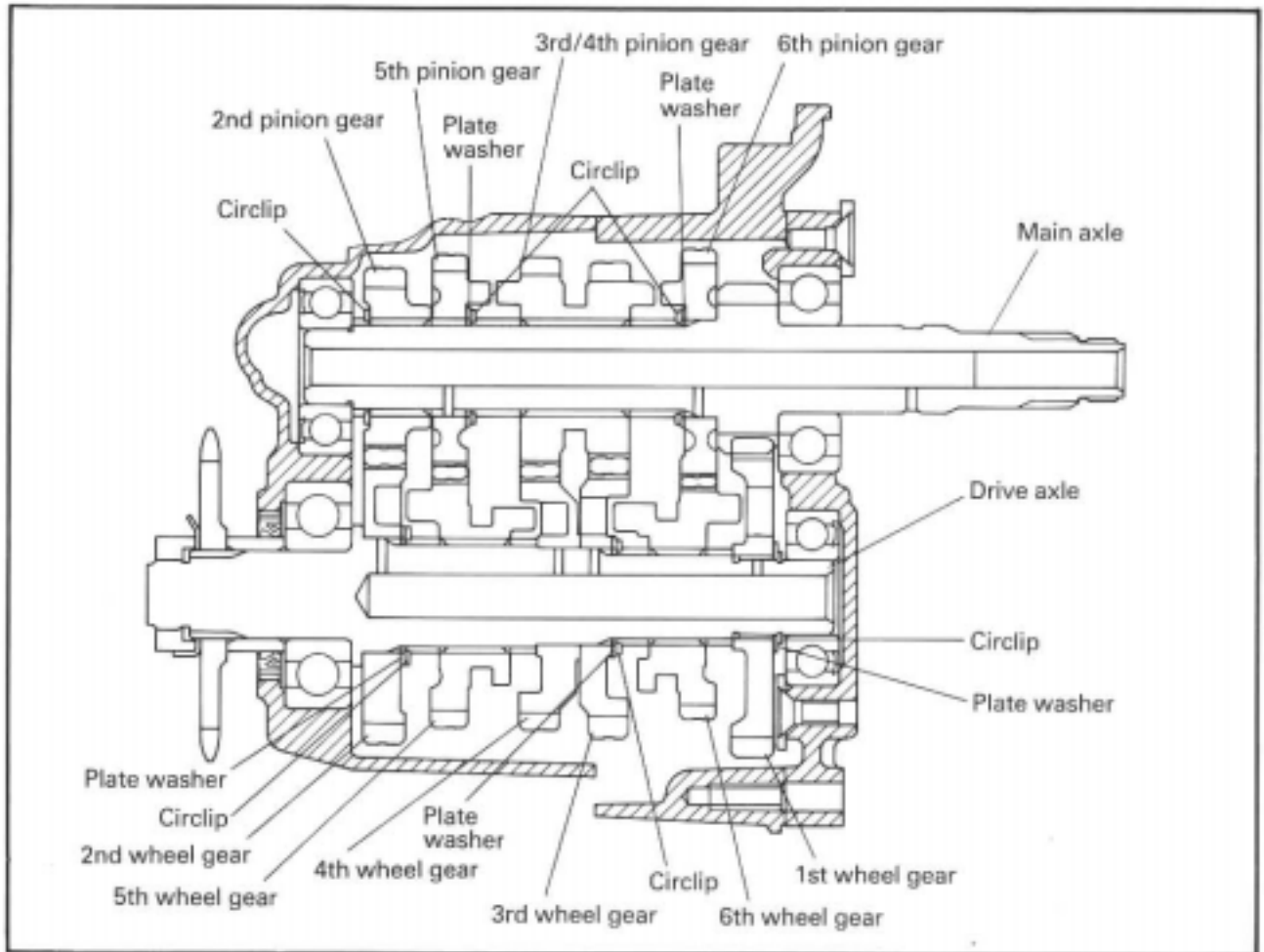

4

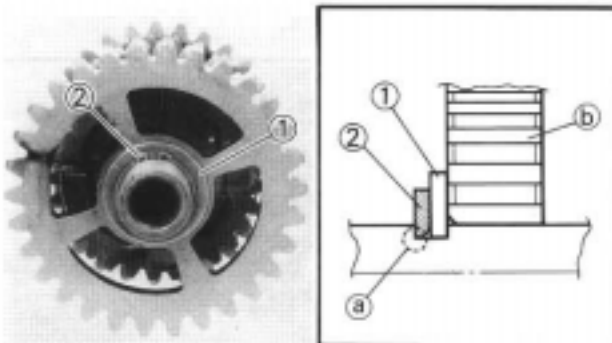

3. Install:

- Circlip ①
- Plain washer ②

NOTE:

- Be sure the circlip sharp-edged corner ① is positioned opposite to the plain washer and gear ②.
- Always use new circlips.
- Be sure the circlip end ③ is positioned at axle spline groove ④.

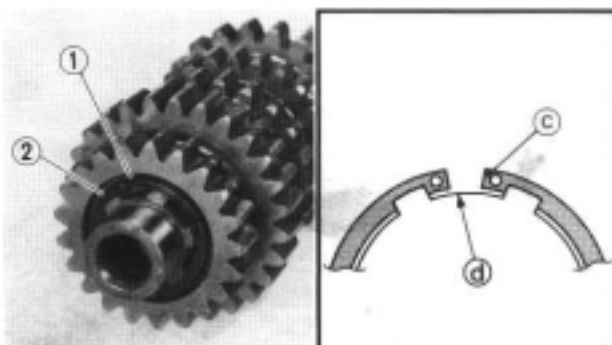

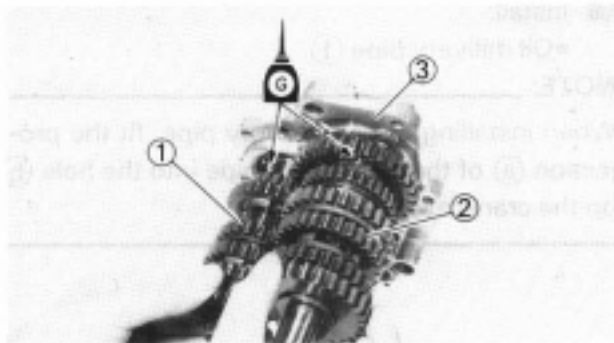

4. Install:
- Main axle ①
 - Drive axle ②

NOTE:

- Apply the transmission oil onto the main axle and drive axle bearings.
- Install the main axle together with the drive axle into the transmission housing ③.

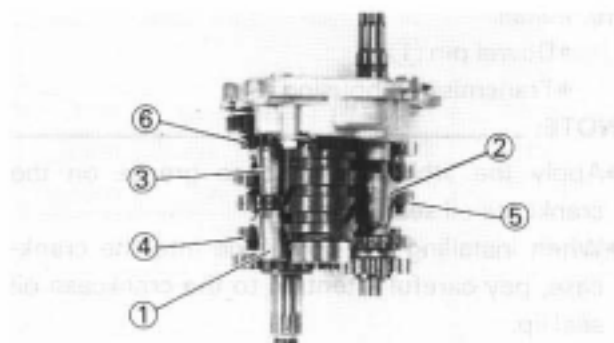

5. Install:
- Shift fork 1 ①
 - Shift fork 2 ②
 - Shift fork 3 ③

NOTE:

- Mesh the shift fork #1 with the 5th wheel gear ④ and #3 with the 6th gear ⑥ on the drive axle.
- Mesh the shift fork #2 with the 3rd/4th pinion gear ⑤ on the main axle.

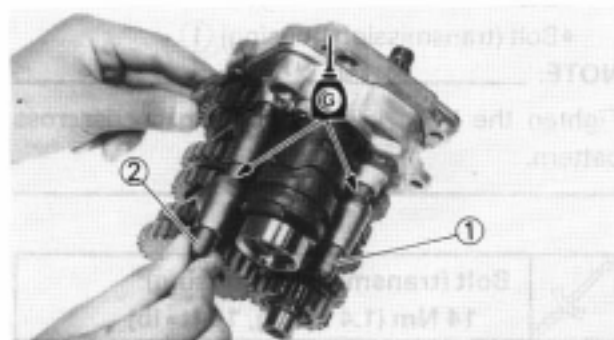

6. Install:
- Guide bar (shorter) ①
 - Guide bar (longer) ②

NOTE:

- Apply the transmission oil onto the guide bars.
- Be sure the short bar is inserted into the shift fork #2 and the long one into #1 and #3.

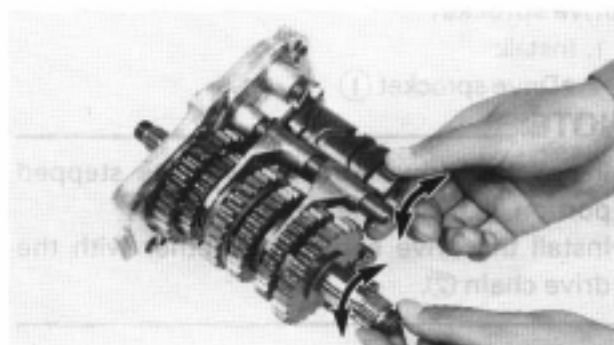

7. Check:
- Shift operation
 - Transmission operation
- Unsmooth operation → Repair.

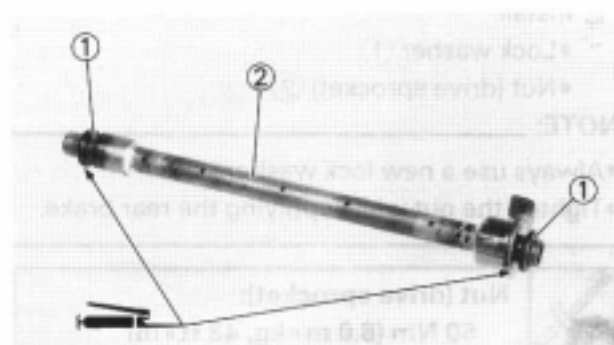

8. Install:
- O-ring ①
 - To oil delivery pipe ②.

NOTE:

Apply the lithium soap base grease on the O-rings.

4

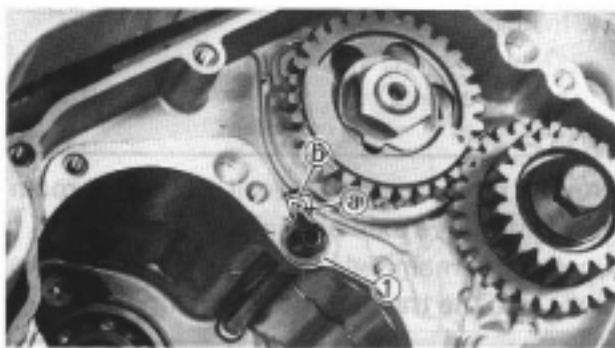

9. Install:

- Oil delivery pipe ①

NOTE: _____

When installing the oil delivery pipe, fit the projection ① of the oil delivery pipe into the hole ② on the crankcase.

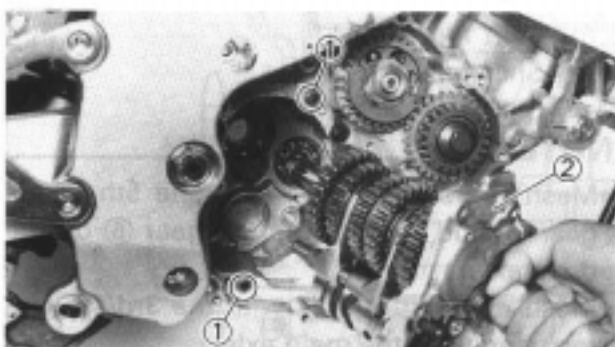

10. Install:

- Dowel pin ①
- Transmission housing ②

NOTE: _____

- Apply the lithium soap base grease on the crankcase oil seal lip.
- When installing the drive axle into the crankcase, pay careful attention to the crankcase oil seal lip.

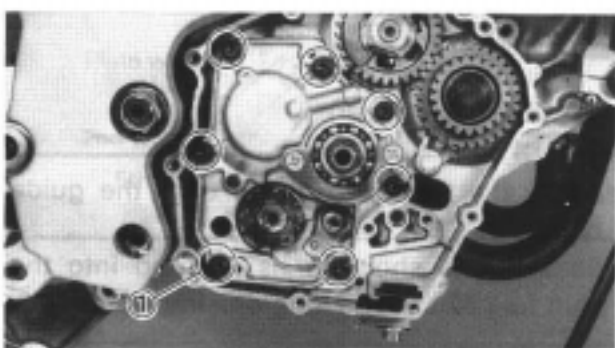

11. Install:

- Bolt (transmission housing) ①

NOTE: _____

Tighten the bolts in stages, using a crisscross pattern.



Bolt (transmission housing):
14 Nm (1.4 m•kg, 10 ft•lb)

Drive sprocket

1. Install:

- Drive sprocket ①

NOTE: _____

- Install the drive sprocket with its stepped portion ① facing the engine.
- Install the drive sprocket together with the drive chain ②.

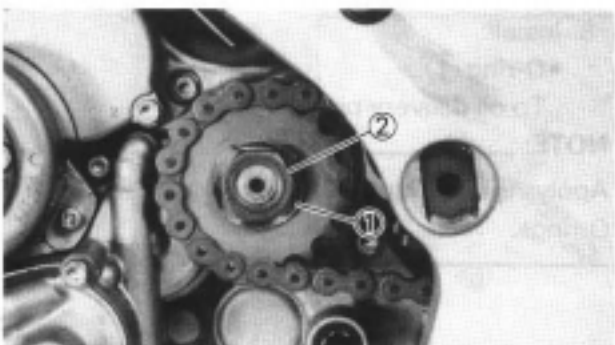
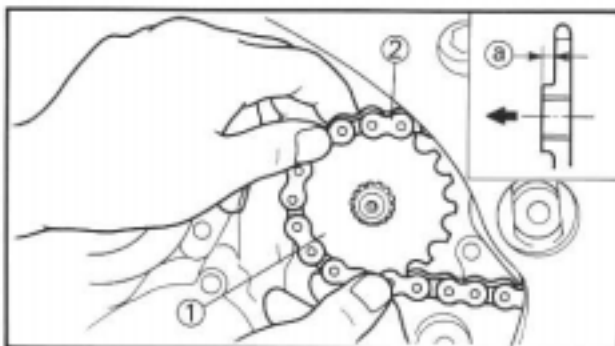

2. Install:

- Lock washer ①
- Nut (drive sprocket) ②

NOTE: _____

- Always use a new lock washer.
- Tighten the nut while applying the rear brake.



Nut (drive sprocket):
60 Nm (6.0 m•kg, 43 ft•lb)

3. Bend the lock washer tab to lock the nut.



**CDI MAGNETO
PREPARATION FOR REMOVAL**



- * Remove the following parts:
 - Cowling
 - Fuel tank
- * Disconnect the CDI magneto lead.

4

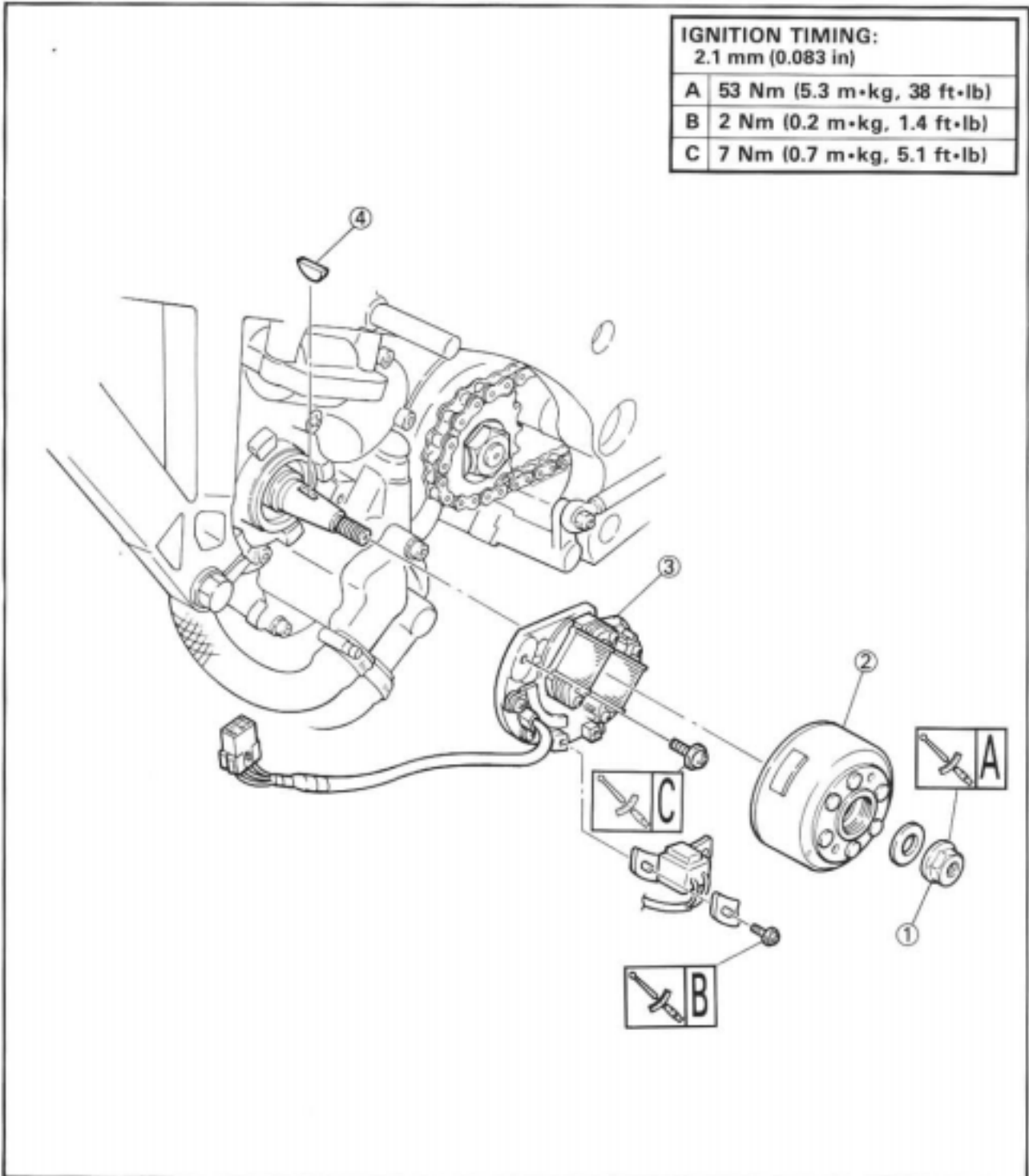



NOTE ON REMOVAL AND REASSEMBLY

•Before servicing, clean the parts, and take care so that foreign material does not enter the crankcase.

Extent of removal: ① CDI magneto removal

Extent of removal	Order	Part name	Q'ty	Remarks
①	1	Nut (rotor)	1	Use special tool. Refer to "REMOVAL POINTS".
	2	Rotor	1	
	3	Stator	1	
	4	Woodruff key	1	

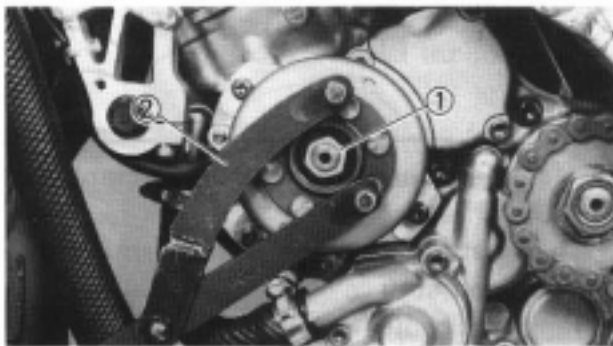

REMOVAL POINTS

Rotor

- Remove:
 - Nut (rotor) ①
 - Plain washer
 Use the rotor holder ②.



Rotor holder:
YU-01235/90890-01235

4



- Remove:
 - Rotor ①
 Use the rotor puller ②.



Rotor puller:
YM-01189/90890-01189

NOTE:

When installing the rotor puller, turn it counterclockwise.

INSPECTION
CDI magneto

- Inspect:
 - Rotor inner surface (a)
 - Stator outer surface (b)
 Damage → Inspect the crankshaft runout and crankshaft bearing.
 If necessary, replace CDI magneto/stator.

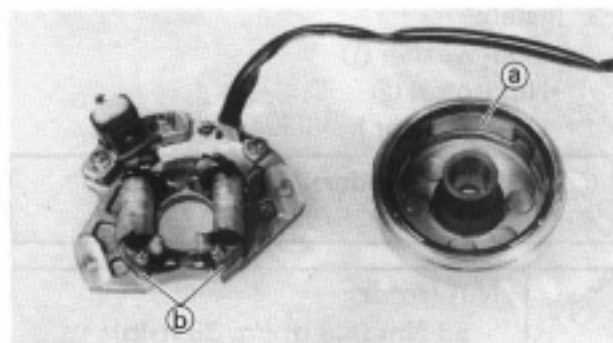

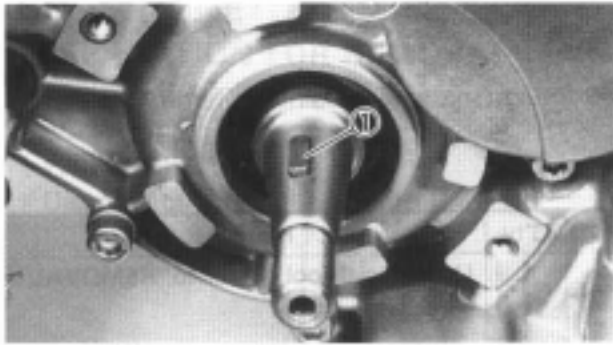

Woodruff key

1. Inspect:
 - Woodruff key ①
 - Damage → Replace.

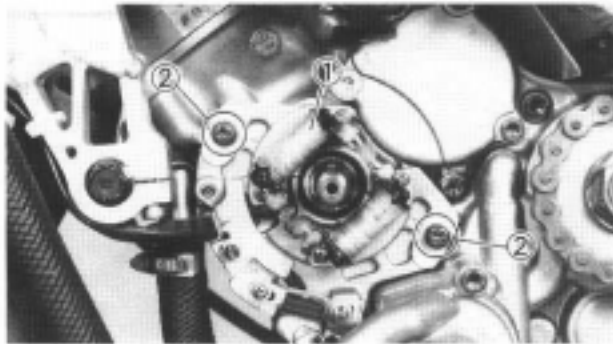

ASSEMBLY AND INSTALLATION

CDI magneto

1. Install:
 - Stator ①
 - Screw (stator) ②

	<p>Screw (stator): 7 Nm (0.7 m•kg, 5.1 ft•lb)</p>
--	--

2. Install:
 - Woodruff key ①
 - Rotor ②

NOTE:

- Clean the tapered portions of the crankshaft and rotor.
- When installing the woodruff key, make sure that its flat surface ① is in parallel with the crankshaft center line ②.
- When installing the rotor, align the keyway ③ of the rotor with the woodruff key.

4

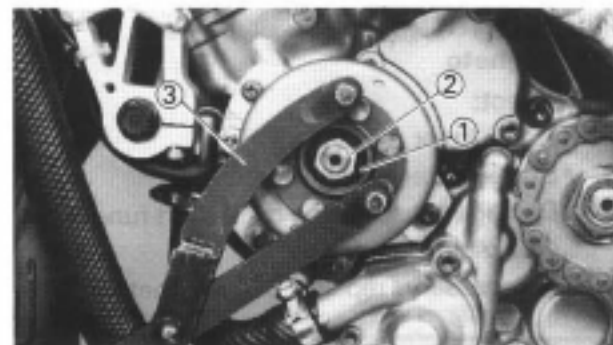
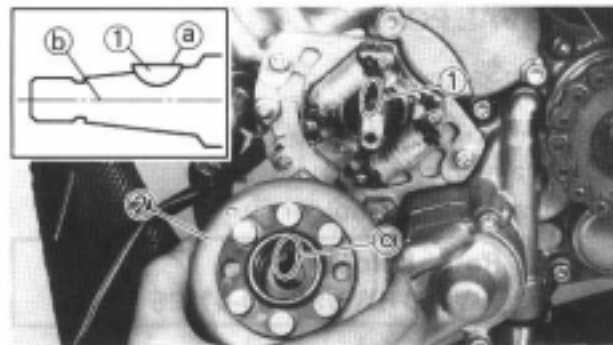

3. Install:
 - Plain washer ①
 - Nut (rotor) ②
 - Use the rotor holder ③.

	<p>Rotor holder: YU-01235/90890-01235</p>
--	--

	<p>Nut (rotor): 53 Nm (5.3 m•kg, 38 ft•lb)</p>
--	---

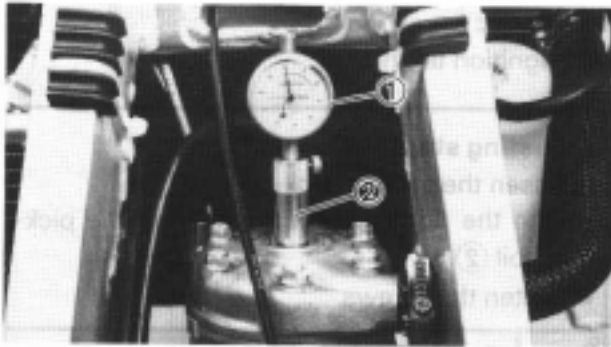

4. Remove:
 - Spark plug
5. Attach:
 - Dial gauge ①
 - Dial gauge stand ②
 To cylinder head.



Dial gauge:
YU-03097/90890-01252

Stand:
YU-01256

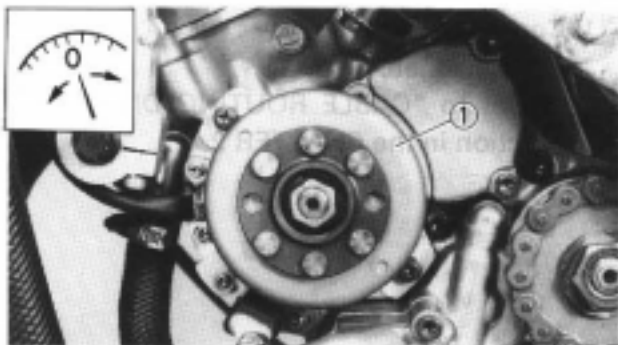

6. Rotate the magneto rotor ① until the piston reaches top dead center (TDC). When this happens, the needle on the dial gauge will stop and reverse directions even though the rotor is being turned in the same direction.
7. Set the dial gauge to zero at TDC.

4

8. From TDC, rotate the rotor clockwise until the dial gauge indicates that the piston is at a specified distance from TDC.



Ignition timing:
2.1 mm (0.083 in)



9. Check:
 - Ignition timing
 Punch mark ① on rotor should be aligned with punch mark ② on pick-up coil.
 Not aligned → Adjust.

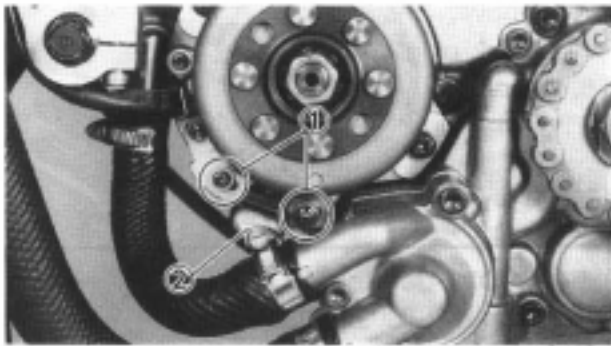

10. Adjust:
- Ignition timing

Adjusting steps:

- Loosen the screws (pick-up coil) ①.
- Align the punch marks by moving the pick-up coil ②.
- Tighten the screws.



Screw (pick-up coil):
2 Nm (0.2 m • kg, 1.4 ft • lb)

4

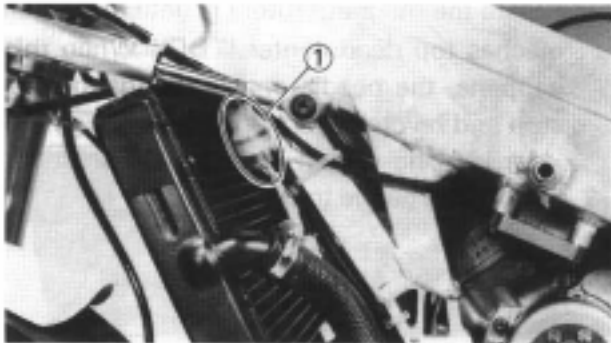

11. Connect:
- CDI magneto lead ①
Refer to "CABLE ROUTING DIAGRAM" section in the CHAPTER 2.



ENGINE REMOVAL

PREPARATION FOR REMOVAL

* Hold the machine by placing suitable stand.

⚠ WARNING

Securely support the machine so there is no danger of it falling over.

- * Remove the cowling.
- * Drain the cooling water.
- * Disconnect the clutch cable at engine side.
- * Disconnect the YPVS cable at engine side.
- * Disconnect the radiator hose 2 and 4 at engine side.
- * Disconnect the CDI magneto lead.
- * Disconnect the spark plug cap.

* Remove the following parts:

- Fuel tank
- Carburetor
- Carburetor cover
- Exhaust pipe
- Drive sprocket
- Shift arm

A	11 Nm (1.1 m•kg, 8.0 ft•lb)
B	30 Nm (3.0 m•kg, 22 ft•lb)

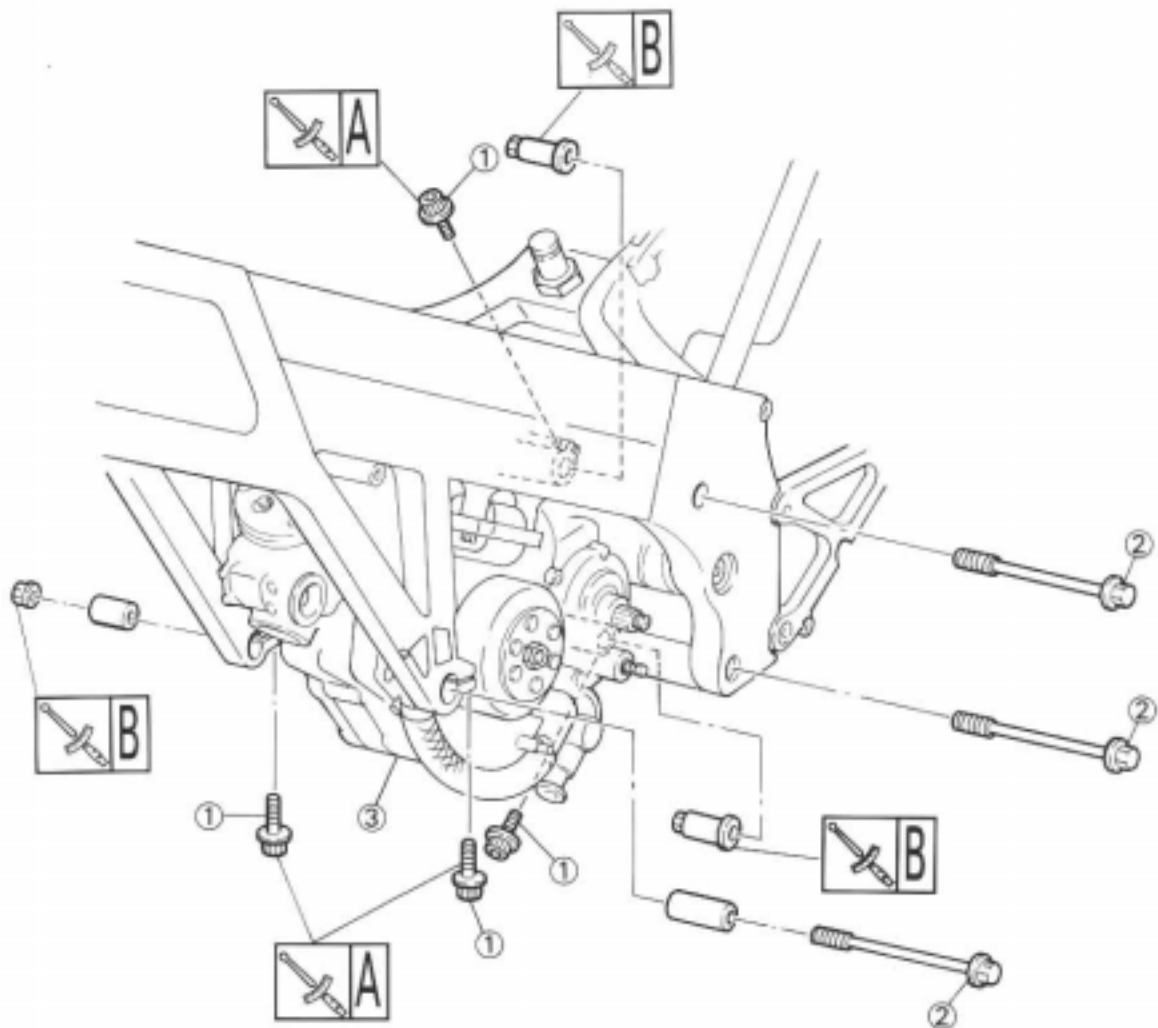



NOTE ON REMOVAL AND REASSEMBLY

•Before servicing, clean the parts, and take care so that foreign material does not enter the crankcase.

Extent of removal: ① Engine removal

Extent of removal	Order	Part name	Q'ty	Remarks
	1	Pinch bolt (engine mounting bolt)	4	Only loosening. Refer to "REMOVAL POINTS".
	2	Engine mounting bolt	3	
	3	Engine	1	

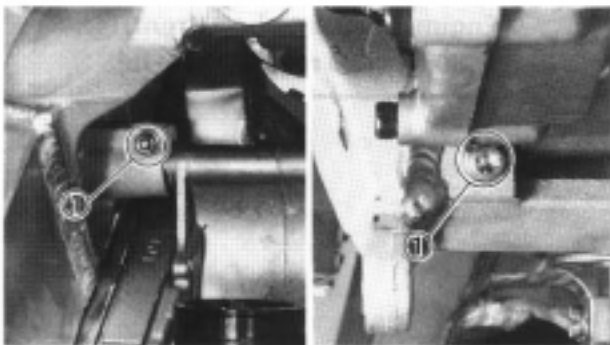

REMOVAL POINTS

Engine removal

1. Loosen:

- Pinch bolt (engine mounting bolt) ①

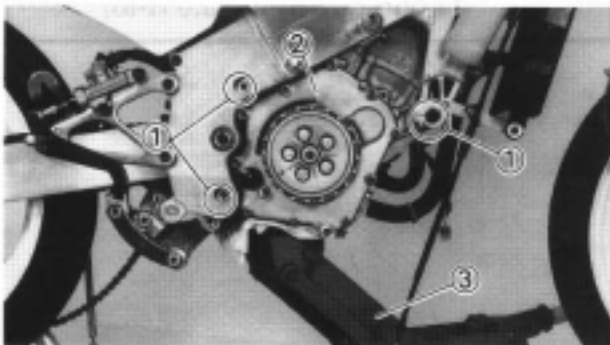
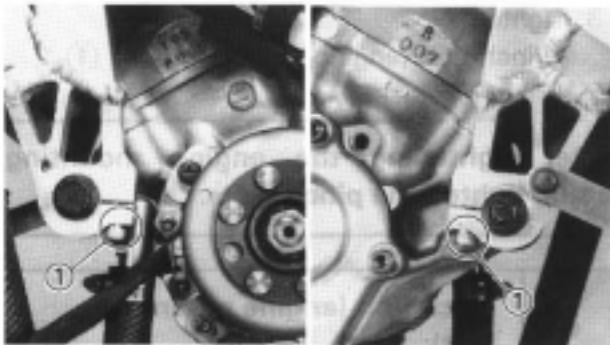

2. Remove:

- Engine mounting bolt ①
- Engine ②

NOTE:

- Before removing the engine, make sure that the couplers, hoses and cables are disconnected.
- Remove the engine by lowering it with a jack ③.

4

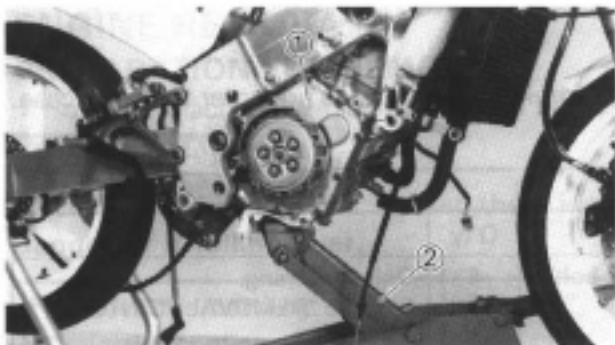

ASSEMBLY AND INSTALLATION

Engine installation

1. Install:

- Engine (1)

NOTE:

Install the engine by raising it into the frame with a jack (2).

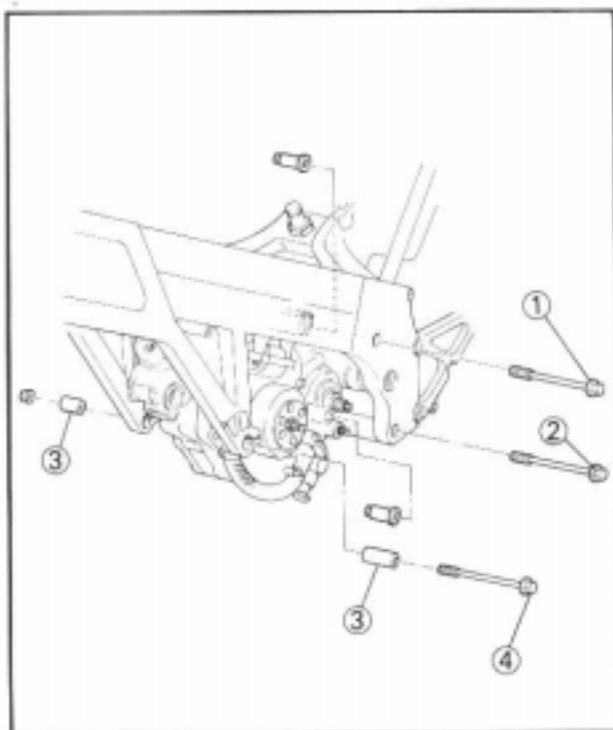

2. Install:

- Engine mounting bolt (upper) (1)
- Engine mounting bolt (lower) (2)
- Engine mounting collar (3)
- Engine mounting bolt (front) (4)



Engine mounting bolt (upper) (1):

30 Nm (3.0 m•kg, 22 ft•lb)

Engine mounting bolt (lower) (2):

30 Nm (3.0 m•kg, 22 ft•lb)

Engine mounting bolt (front) (4):

30 Nm (3.0 m•kg, 22 ft•lb)

4

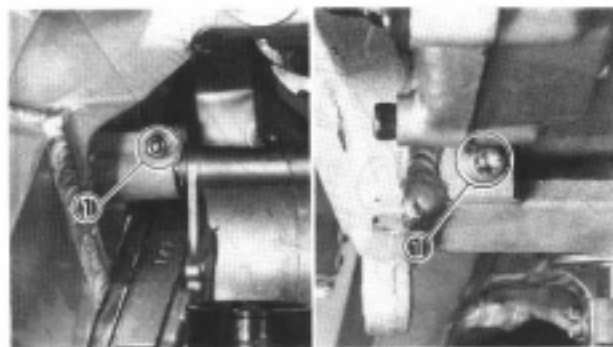

3. Tighten:

- Pinch bolt (engine mounting bolt) (1)

CAUTION:

After tightening the engine mounting bolts, tighten the pinch bolts.



Pinch bolt (engine mounting bolt):

11 Nm (1.1 m•kg, 8.0 ft•lb)

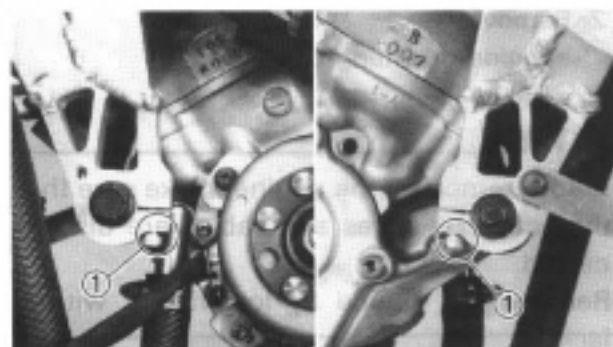



**CRANKCASE, CRANKSHAFT AND WATER PUMP
PREPARATION FOR REMOVAL**

*Remove the cowling.

*Drain the coolant.

*Remove the exhaust pipe.

*Remove the engine.

*Drain the transmission oil.

*Remove the following parts:

•Cylinder head

•Radiator hose 3

•Cylinder

•Balancer

•Piston

•Crankcase cover (left and right)

•Clutch

•Primary drive gear

•Reed valve

•Rotor and starter

•Push lever axle

•Transmission

CRANKSHAFT RUNOUT LIMIT:

0.03 mm (0.0012 in)

CONNECTION ROD BIG END SIDE

CLEARANCE:

0.2~0.7 mm (0.008~0.028 in)

CONNECTING ROD SMALL END

FREE PLAY:

0.8~1.0 mm (0.031~0.039 in)

CRANK WIDTH:

52.90~52.95 mm (2.083~2.085 in)

A 16 Nm (1.6 m • kg, 11 ft • lb)

B 11 Nm (1.1 m • kg, 8.0 ft • lb)

C 23 Nm (2.3 m • kg, 17 ft • lb)

4

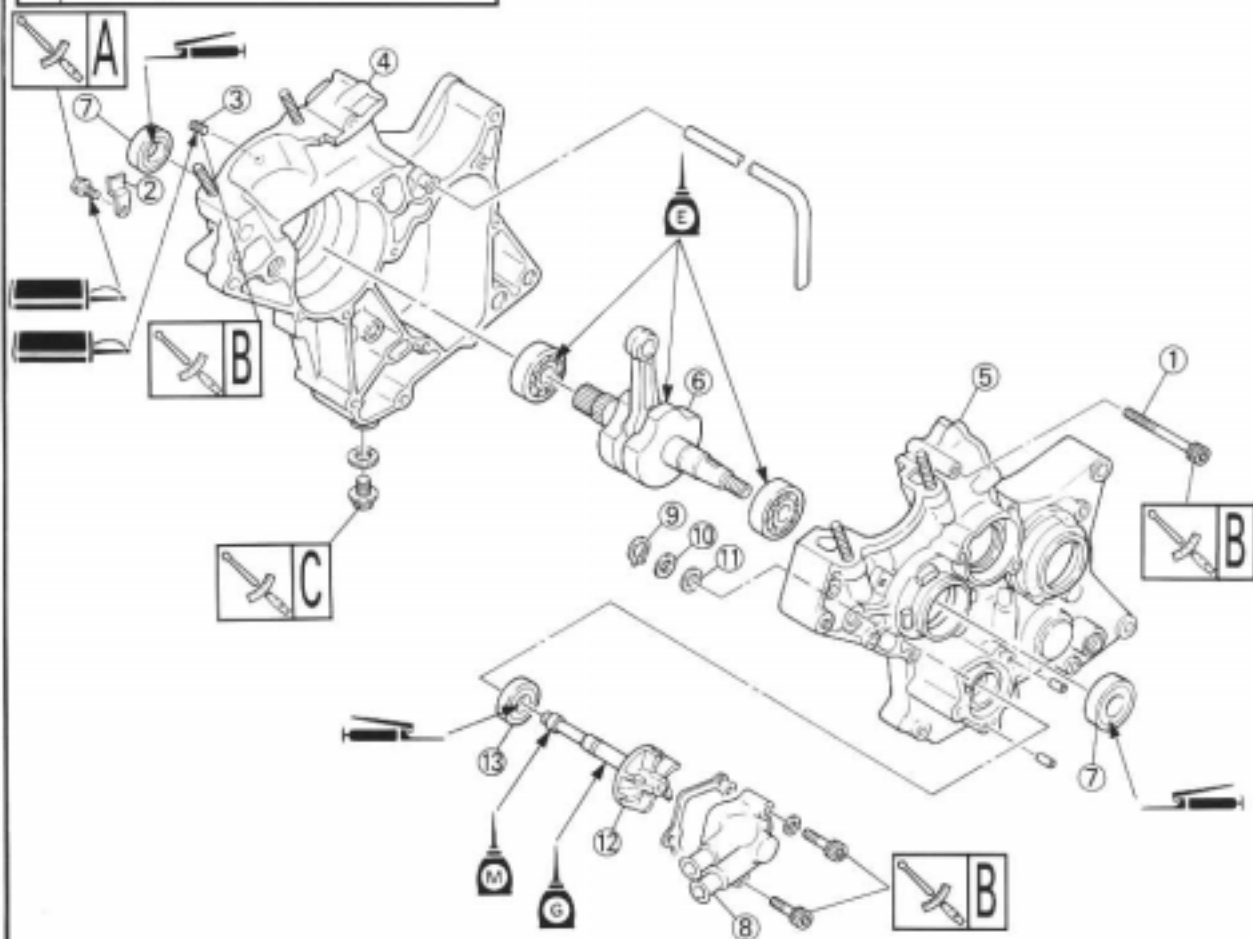



NOTE ON REMOVAL AND REASSEMBLY

- Before servicing, clean the parts, and take care so that foreign material does not enter the crankcase.
- Remove the gasket adhered on the contacting surface.
- For reassembly, the removed parts should be cleaned and apply the transmission oil onto the sliding surface.

- Extent of removal:
- ① Crankcase separation
 - ② Crankcase removal
 - ③ Oil seal (crankshaft) removal
 - ④ Impeller shaft removal
 - ⑤ Oil seal (impeller shaft) removal

Extent of removal	Order	Part name	Q'ty	Remarks
	1	Bolt (crankcase)	13	Use special tool. Refer to "REMOVAL POINTS".
	2	Holder	1	
	3	Blind plug	1	
	4	Crankcase (right)	1	
	5	Crankcase (left)	1	
	6	Crankshaft	1	Use special tool. Refer to "REMOVAL POINTS".
	7	Oil seal (crankshaft)	2	Refer to "REMOVAL POINTS".
	8	Water pump housing cover	1	
	9	Circlip	1	
	10	Plain washer [T=1.0 mm (0.04 in)]	1	
	11	Plain washer [T=2.0 mm (0.08 in)]	1	Refer to "REMOVAL POINTS".
	12	Impeller shaft	1	
	13	Oil seal (impeller shaft)	1	

4

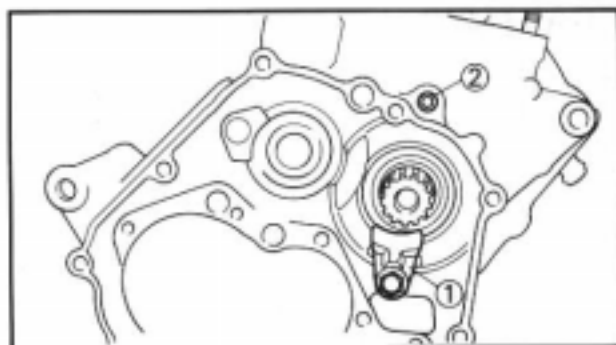

REMOVAL POINTS

Crankcase

- Remove:
 - Holder ①
 - Blind plug ②

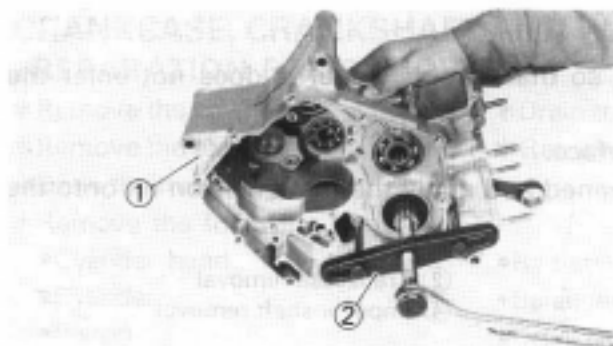

2. Remove:

- Crankcase (right) ①
Use the crankcase separating tool ②.



Crankcase separating tool:
YU-01135-A/90890-01135

NOTE:

- Fully tighten the tool holding bolts, but make sure the tool body is parallel with the case. If necessary, one screw may be backed out slightly to level tool body.
- As pressure is applied, alternately tap on the front engine mounting boss and rear engine mounting boss.

CAUTION:

Use soft hammer to tap on the case half. Tap only on reinforced portions of case. Do not tap on gasket mating surface. Work slowly and carefully. Make sure the case halves separate evenly. If one end "hangs up," take pressure off the push screw, realign, and start over. If the cases do not separate, check for a remaining case screw or fitting. Do not force.

4

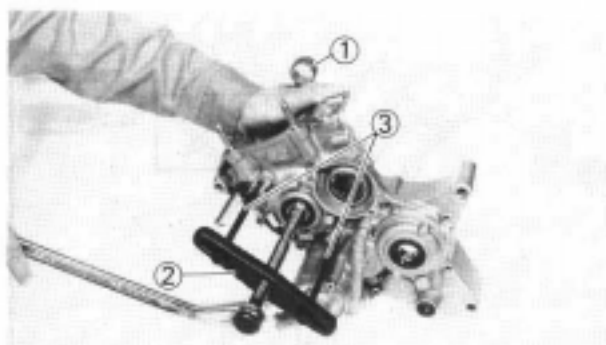
**Crankshaft**

1. Remove:

- Crankshaft ①
Use the crankcase separating tool ② and crankcase separating bolt ③.



Crankcase separating tool:
YU-01135-A/90890-01135
YM-01135/90890-01135

CAUTION:

Do not use a hammer to drive out the crankshaft.

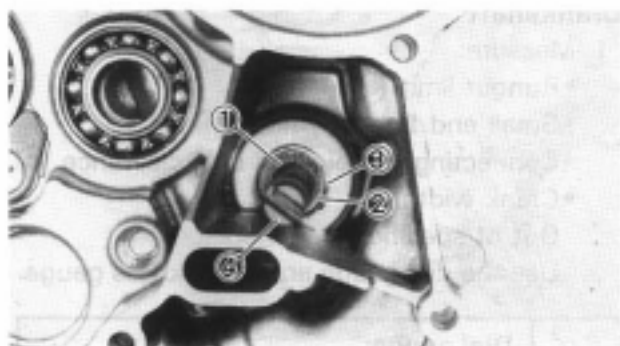

Impeller shaft

1. Remove:
 - Circlip ①
 - Plain washer [T=1.0 mm (0.04 in)] ②
 - Plain washer [T=2.0 mm (0.08 in)] ③
 - Impeller shaft ④

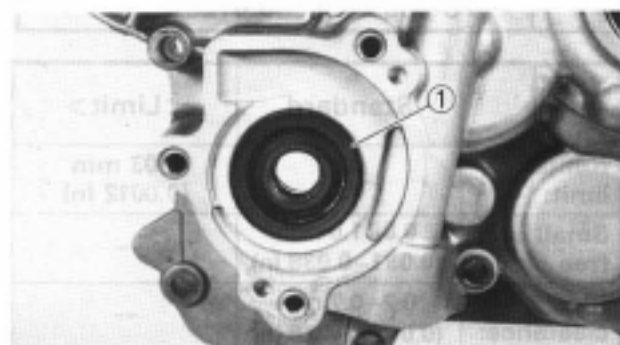

Oil seal

NOTE:

It is not necessary to disassembly the water pump, unless there is no abnormality such as excessive change in coolant level, discoloration of coolant, or milky transmission oil.

1. Remove:
 - Oil seal ①
 From crankcase (right).

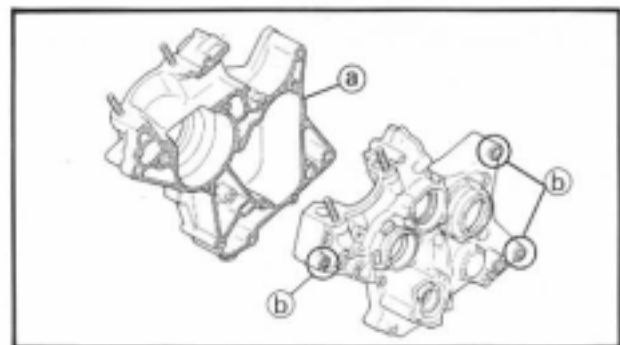

INSPECTION

Crankcase

1. Inspect:
 - Contacting surface ①
Scratches→Replace.
 - Engine mounting boss ②, crankcase
Cracks/Damage→Replace.

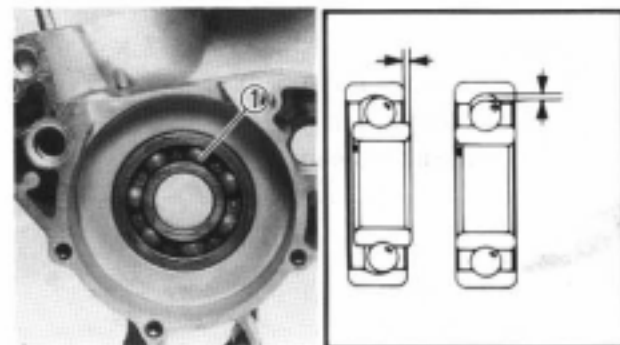

2. Inspect:
 - Bearings ①
Rotate inner race with a finger.
Rough spot/Seizure→Replace.

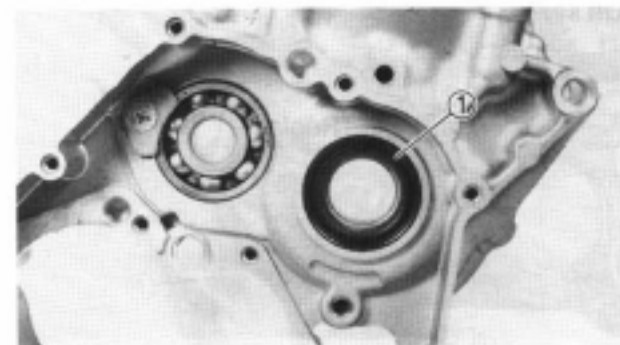

3. Inspect:
 - Oil seal ①
Damage→Replace.

4

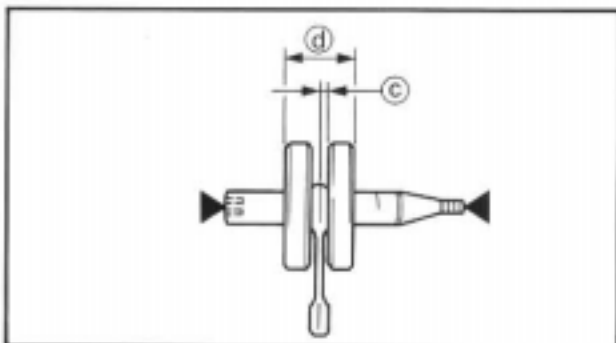
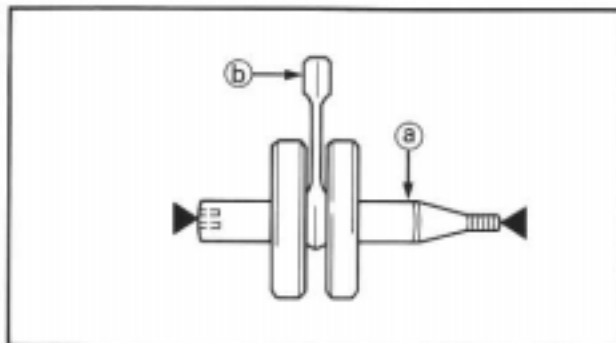

Crankshaft

1. Measure:

- Runout limit (a)
- Small end free play limit (b)
- Connecting rod big end side clearance (c)
- Crank width (d)

Out of specification → Replace.

Use the dial gauge and a thickness gauge.



Dial gauge:

YU-03097/90890-01252



	Standard	< Limit >
Runout limit:	—	0.03 mm (0.0012 in)
Small end free play:	0.8–1.0 mm (0.031~0.039 in)	—
Side clearance:	0.2–0.7 mm (0.008~0.028 in)	—
Crank width:	52.90–52.95 mm (2.083~2.085 in)	—

4

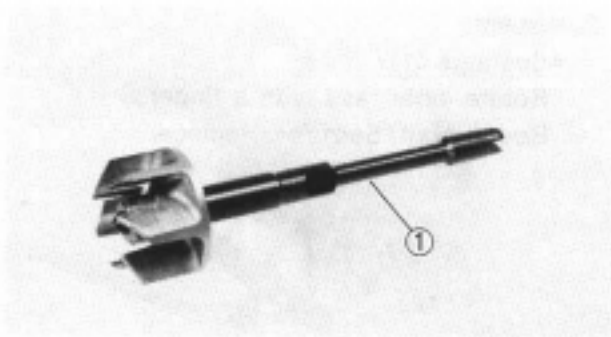

Impeller shaft

1. Inspect:

- Impeller shaft (1)
- Bend/Wear/Damage → Replace.
- Fur deposits → Clean.

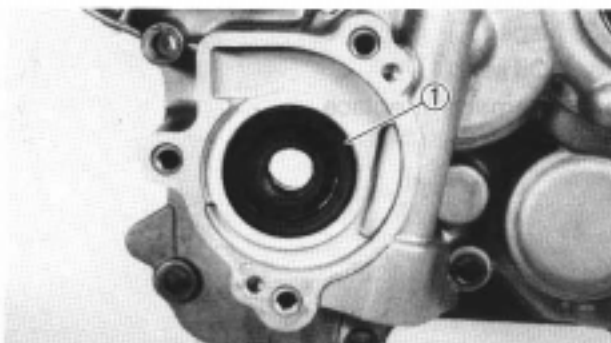

Oil seal

1. Inspect:

- Oil seal (1)
- Wear/Damage → Replace.

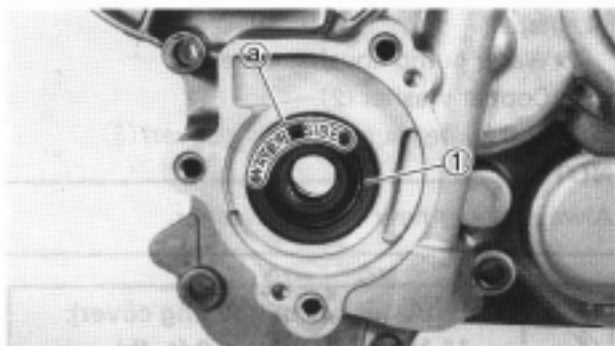
**ASSEMBLY AND INSTALLATION****Oil seal (impeller shaft)**

1. Install:

- Oil seal ①
To crankcase (right).

NOTE:

- Always use a new oil seal.
- Install the oil seal with the "WATER SIDE" mark ① on the outside.

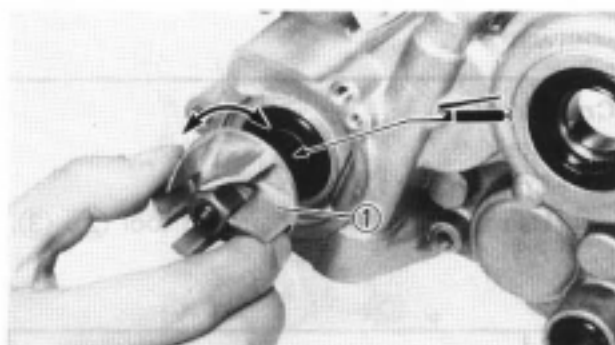
**Impeller shaft**

1. Install:

- Impeller shaft ①

NOTE:

- Take care so that the oil seal lip is not damaged or the spring does not slip off its position.
- When installing the impeller shaft, apply the lithium soap base grease to oil seal lip and impeller shaft. And install the shaft while turning it.

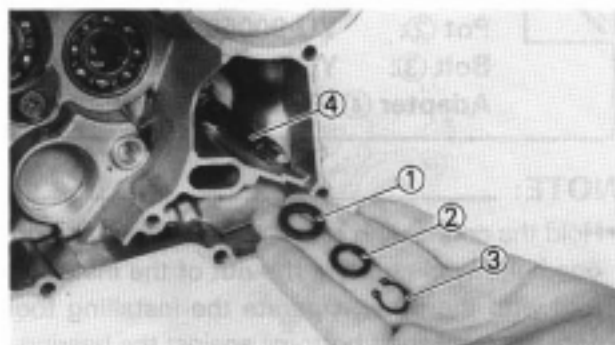

2. Install:

- Plain washer [T=2.0 mm (0.08 in)] ①
- Plain washer [T=1.0 mm (0.04 in)] ②
- Circlip ③
To impeller shaft ④.

NOTE:

- Install the plain washer of 2 mm (0.08 in) thickness first.
- Always use a new circlip.

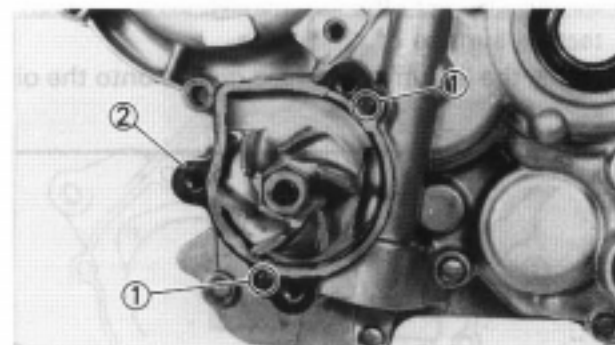

3. Install:

- Dowel pin ①
- Gasket (water pump housing cover) ②

NOTE:

Always use a new gasket.

4

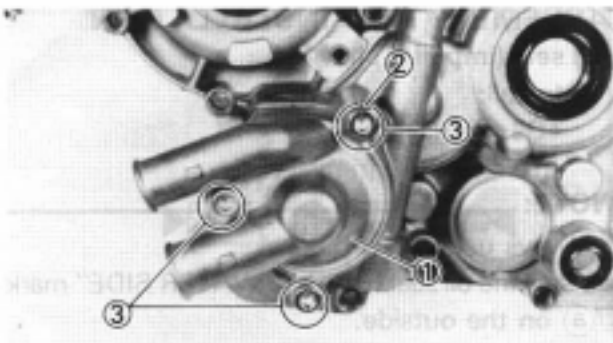

4. Install:
- Water pump housing cover ①
 - Copper washer ②
 - Bolt (water pump housing cover) ③

NOTE: _____

Always use a new copper washer.

	Bolt (water pump housing cover): 11 Nm (1.1 m•kg, 8.0 ft•lb)
---	--

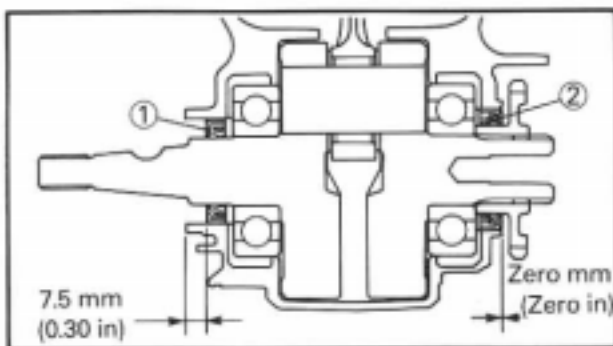

Oil seal (crankshaft)

1. Install:
- Oil seal (left) ①
 - Oil seal (right) ②

NOTE: _____

- Always use new oil seals.
- Apply the lithium soap base grease on the oil seal lip.
- Install the oil seal with its manufacture's marks, numbers or "OUT SIDE" mark facing outward.

4

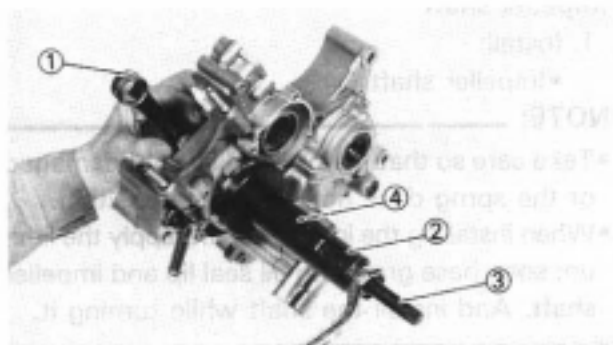

Crankshaft

1. Install:
- Crankshaft ①
- Use the crankshaft installing tool ②, ③, ④.

	Crankshaft installing tool:
	Pot ②: YU-90050/90890-01274
	Bolt ③: YU-90050/90890-01275
	Adapter ④: YU-90063/90890-01278

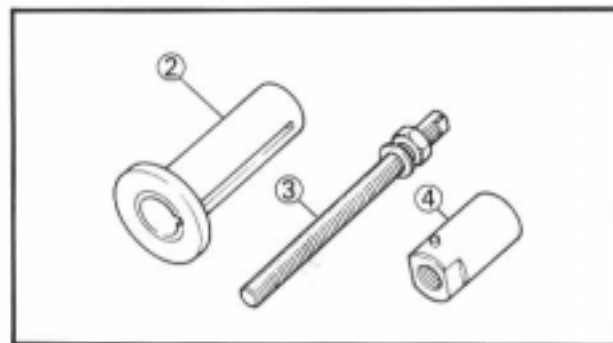

NOTE: _____

- Hold the connecting rod at top dead center with one hand while turning the nut of the installing tool with the other. Operate the installing tool until the crankshaft bottoms against the bearing.
- Before installing the crankshaft, clean the contacting surface of crankcase.
- Apply the lithium soap base grease onto the oil seal lip.

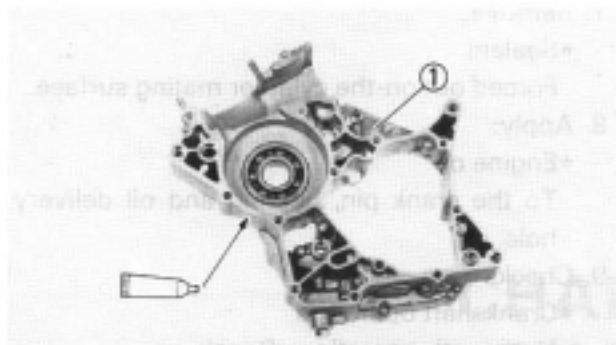

2. Apply:
 - Sealant
 Onto the crankcase (right) ①.

	Quick gasket®: ACC-11001-05-01 Yamaha bond No. 1215 90890-85505
--	--

NOTE: _____
 Clean the contacting surface of crankcase (left and right) before applying the sealant.

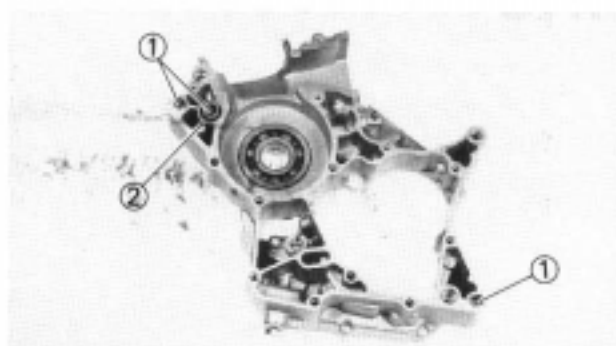

3. Install:
 - Dowel pin ①
 - O-ring ②
 To crankcase (right).

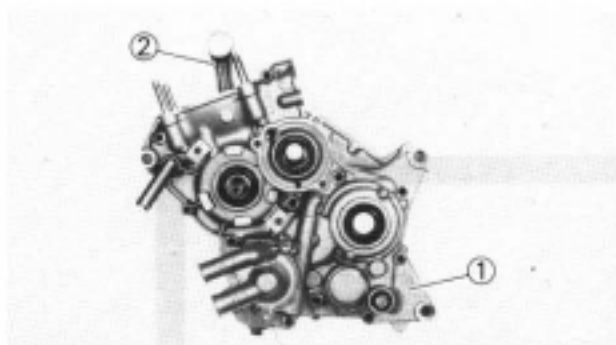

4. Install:
 - Crankcase (left) ①
 To crankcase (right).

NOTE: _____
 • When installing the crankcase (left), the connecting rod ② should be positioned at TDC (top dead center).
 • Fit the crankcase (left) onto the crankcase (right). Tap lightly on the case with soft hammer.

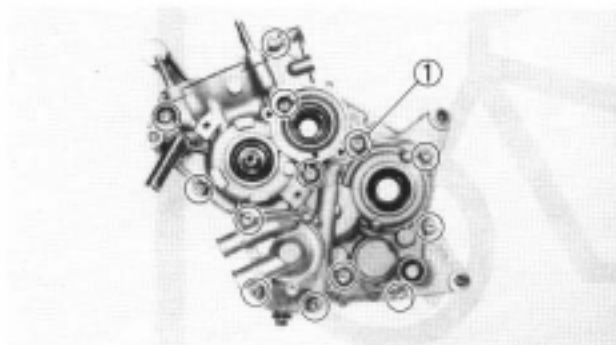

5. Tighten:
 - Bolt (Crankcase) ①

NOTE: _____
 Tighten the crankcase tightening screws in stage, using a crisscross pattern.

	Bolt (crankcase): 11 Nm (1.1 m•kg, 8.0 ft•lb)
--	--

6. Install:
 - Holder ①
 - Bolt (holder) ②
 - Blind plug ③

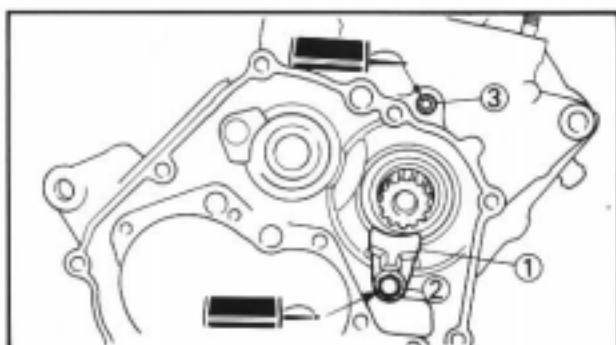

	Bolt (holder): 16 Nm (1.6 m•kg, 11 ft•lb) LOCTITE®
	Blind plug: 11 Nm (1.1 m•kg, 8.0 ft•lb) LOCTITE®

4



7. Remove:
 - Sealant
Forced out on-the cylinder mating surface.
8. Apply:
 - Engine oil
To the crank pin, bearing and oil delivery hole.
9. Check:
 - Crankshaft operation
Unsmooth operation→Repair.

4



FRONT WHEEL PREPARATION FOR REMOVAL

* Hold the machine by placing the suitable stand.

⚠ WARNING

Support the machine securely so there is no danger of it falling over.

WHEEL RUNOUT LIMIT:	
VERTICAL	
1.0 mm (0.04 in)	
LATERAL	
0.5 mm (0.02 in)	
WHEEL AXLE BENDING LIMIT:	
0.25 mm (0.010 in)	
DISC WEAR LIMIT:	
3.5 mm (0.14 in)	
DISC DEFLECTION LIMIT:	
0.3 mm (0.01 in)	
COLD TIRE PRESSURE:	
190 kPa (1.9 kg/cm ² , 27 psi)	
A	23 Nm (2.3 m • kg, 17 ft • lb)
B	20 Nm (2.0 m • kg, 14 ft • lb)
C	48 Nm (4.8 m • kg, 35 ft • lb)

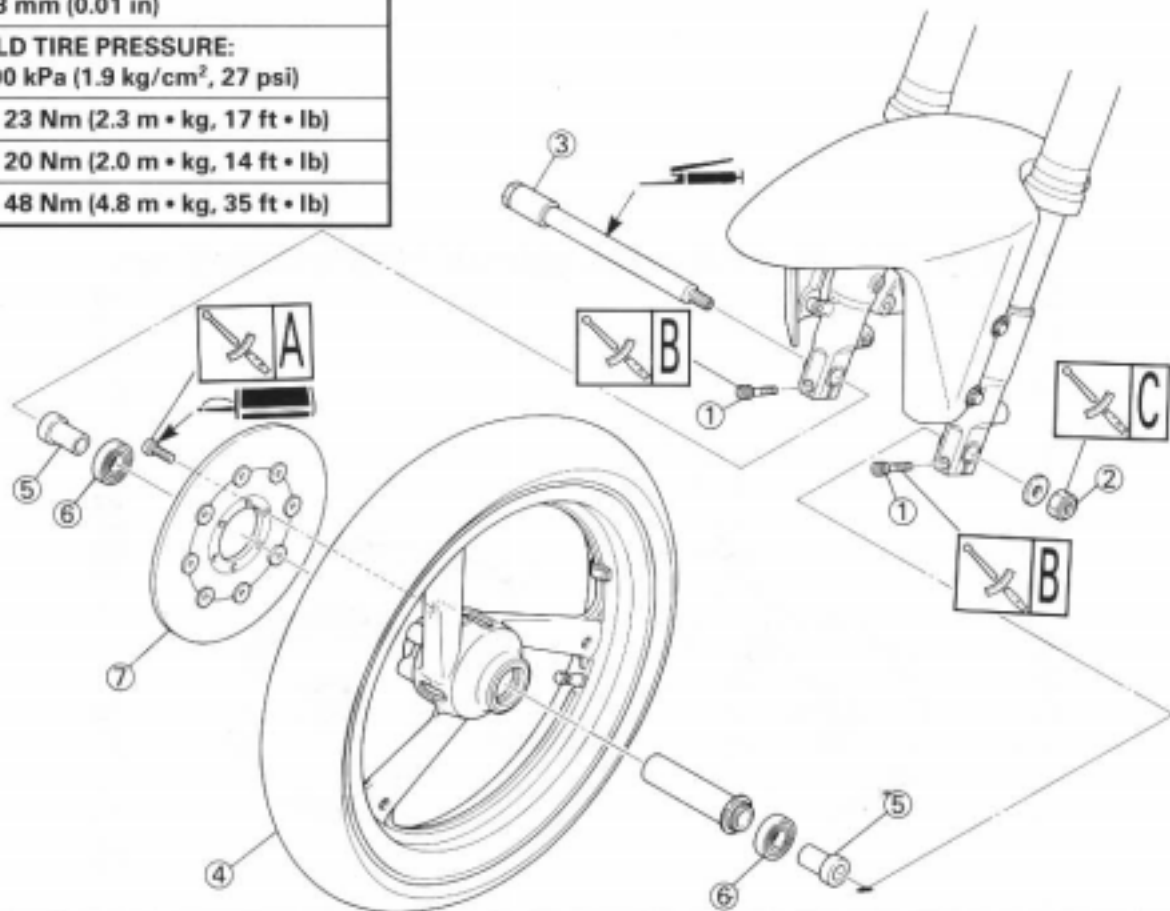

5

Extent of removal: ① Front wheel removal ② Wheel bearing removal ③ Brake disc removal

Extent of removal	Order	Part name	Q'ty	Remarks
①	1	Bolt (axle holder)	2	Only loosening.
②	2	Nut (front wheel axle)	1	
③	3	Front wheel axle	1	
	4	Front wheel	1	
	5	Collar	2	
	6	Bearing	2	Refer to "REMOVAL POINTS".
③	7	Brake disc	1	

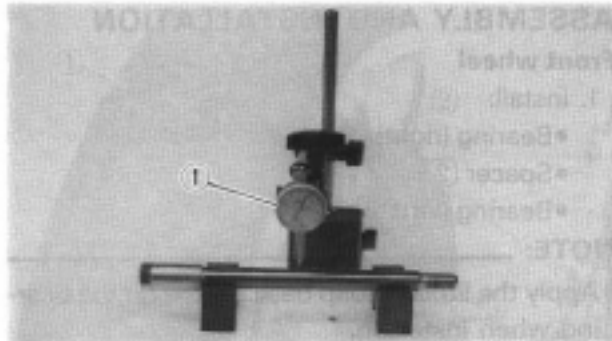
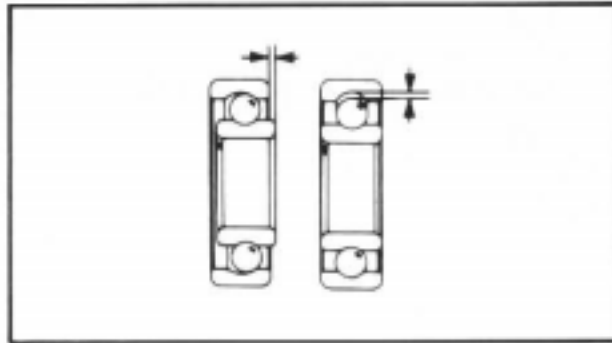
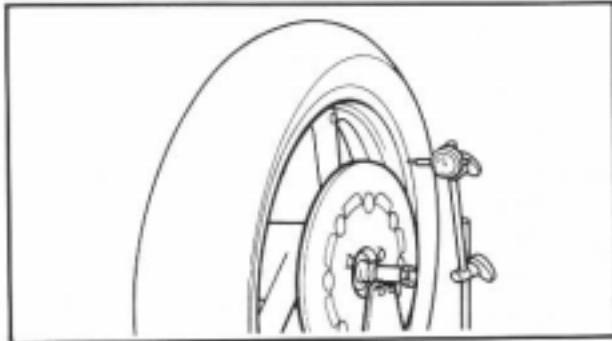
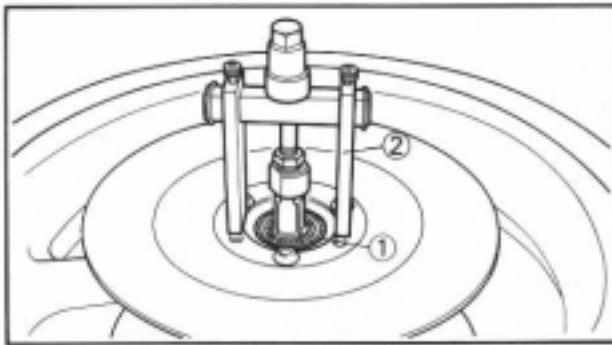

REMOVAL POINTS

Wheel bearing (if necessary)

1. Remove:
 - Bearing ①

NOTE:

Remove the bearing ① using a general bearing puller ②.

INSPECTION

Front wheel

1. Measure:
 - Wheel runout
 Out of limit → Replace.



Wheel runout limit:

Radial: 1.0 mm (0.04 in)

Lateral: 0.5 mm (0.02 in)

2. Inspect:

- Bearing
- Rotate inner race with a finger.
Rough spot/Seizure → Replace.

NOTE:

Replace the bearings and wheel collar as a set.

Front wheel axle

1. Inspect:
 - Wheel axle bends
 Out specification → Replace.
Use dial gauge ①.



Wheel axle bending limit:

0.25 mm (0.010 in)

NOTE:

The bending value is shown by one half of the dial gauge reading.

⚠ WARNING

Do not attempt to straighten a bent axle.

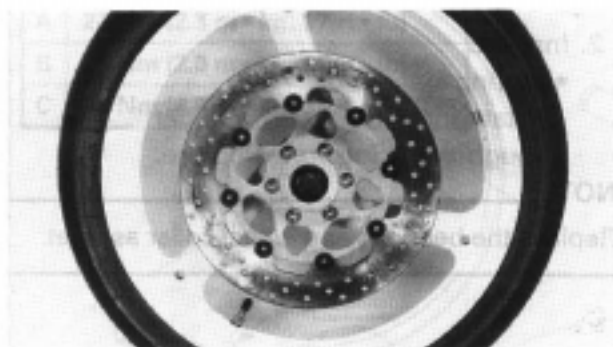
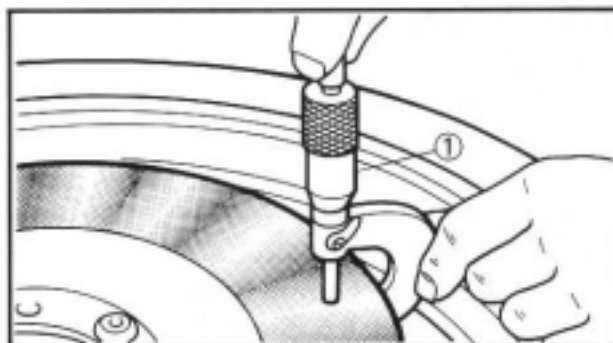
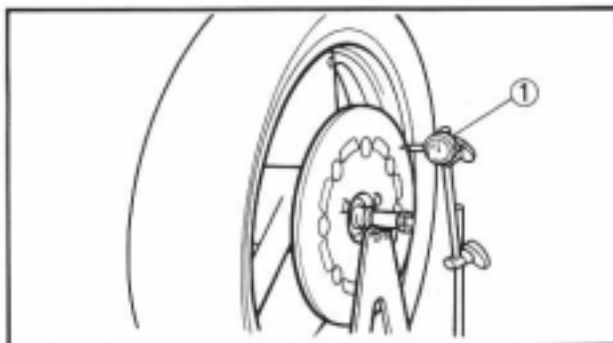
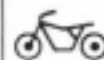
**Brake disc**

1. Inspect:
 - Brake disc deflection
Use dial gauge ①.
Out of specification → Inspect wheel runout.
If wheel runout is in good condition, replace the brake disc.



Disc deflection limit:
0.3 mm (0.01 in)

2. Inspect:
 - Brake disc thickness
Use micrometer ①.
Out of limit → Replace.



Disc wear limit:

Standard	Limit
4.0 mm (0.16 in)	3.5 mm (0.14 in)

3. Inspect:
 - Brake disc surface
Score marks/Damage → Replace.

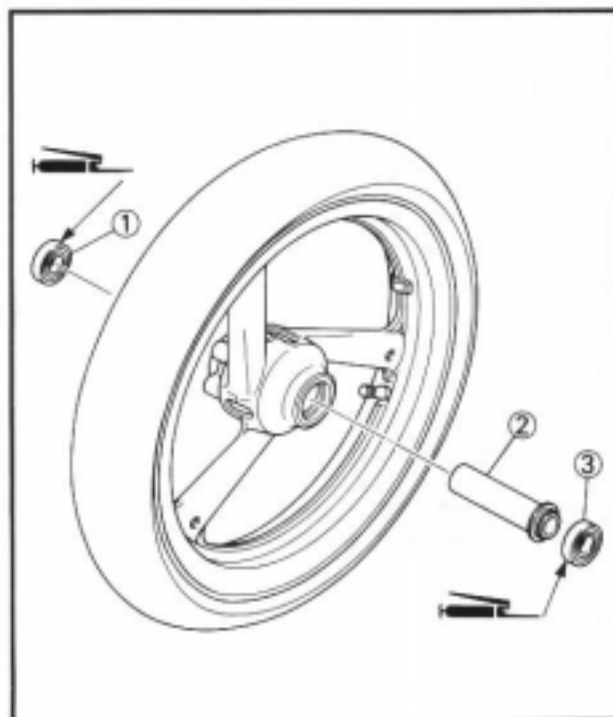
5**ASSEMBLY AND INSTALLATION****Front wheel**

1. Install:
 - Bearing (right) ①
 - Spacer ②
 - Bearing (left) ③

NOTE:

- Apply the lithium soap base grease on the bearing when installing.
- Use a socket that matches the outside diameter of the race of the bearing.
- Right side of bearing shall be installed first.

CAUTION:

Do not strike the inner race of balls of the bearing. Contact should be made only with the outer race.

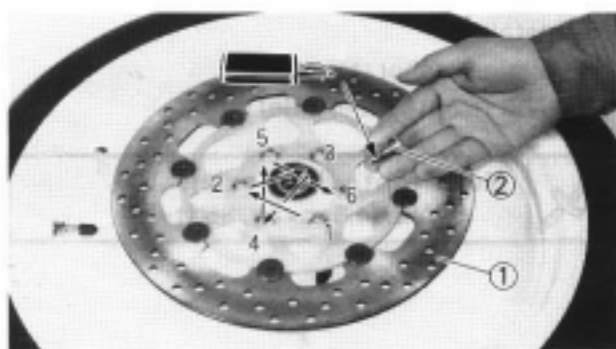

2. Install:

- Brake disc ①
- Bolt (brake disc) ②

NOTE: _____

Tighten the bolts in stage, using a crisscross pattern.



Bolt (brake disc):
 23 Nm (2.3 m•kg, 17 ft•lb)
LOCTITE®

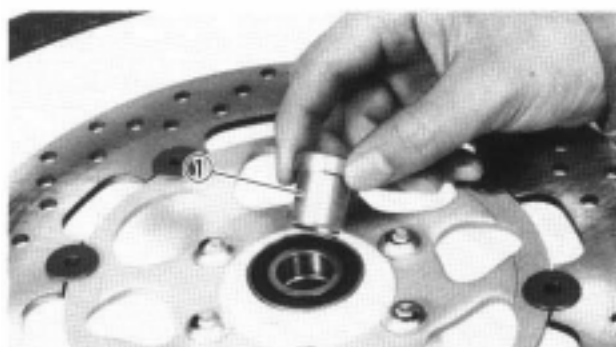

3. Install:

- Collar ①

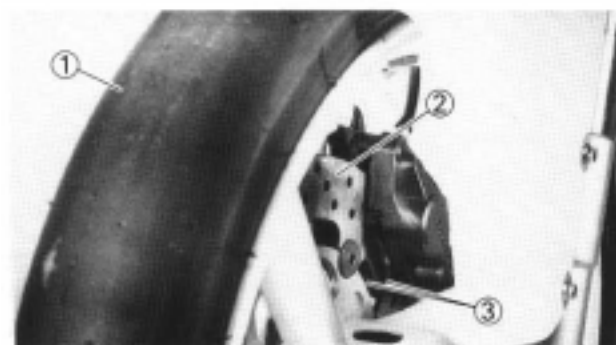

4. Install:

- Front wheel ①

NOTE: _____

Install the brake disc ② between the brake pads ③ correctly.

5

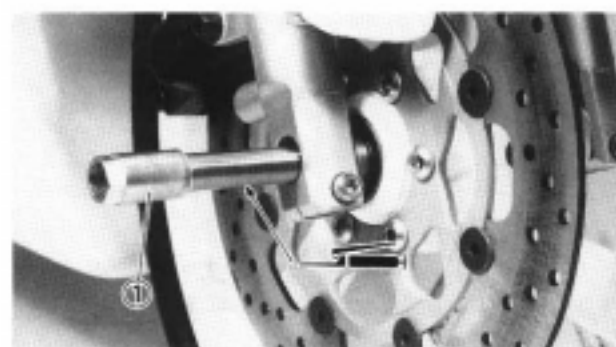

5. Install:

- Front wheel axle ①

NOTE: _____

- Apply the lithium soap base grease onto the wheel axle.
- Insert the wheel axle from right side.

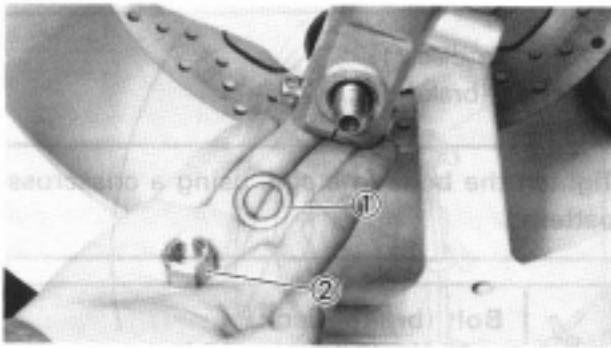

6. Install:

- Plain washer ①
- Nut (front wheel axle) ②



Nut (front wheel axle):
48 Nm (4.8 m•kg, 35 ft•lb)

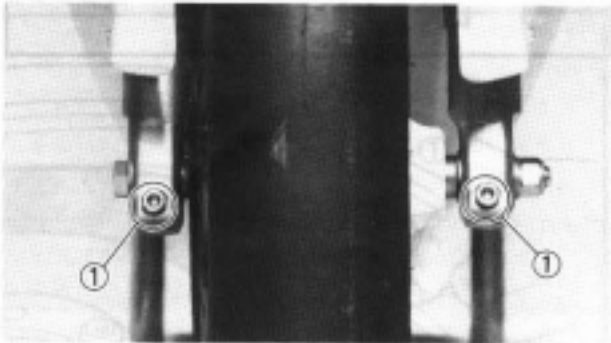

7. Tighten:

- Bolt (axle holder) ①



Bolt (axle holder):
20 Nm (2.0 m•kg, 14 ft•lb)



**REAR WHEEL
PREPARATION FOR REMOVAL**

* Hold the machine by placing the suitable stand.

⚠ WARNING

Support the machine securely so there is no danger of it falling over.

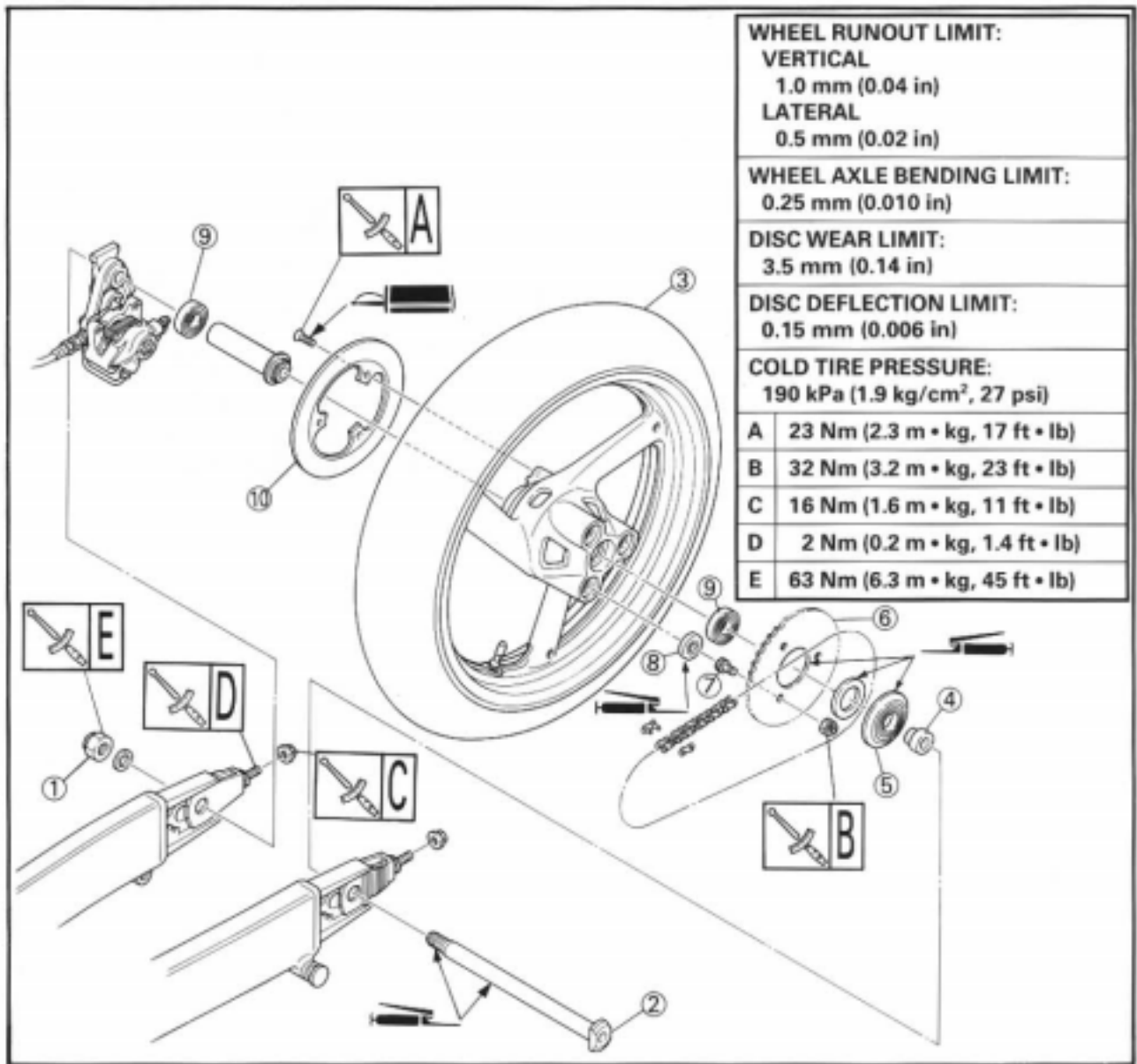

5

- Extent of removal: ① Rear wheel axle removal ② Wheel bearing removal
 ③ Driven sprocket removal ④ Brake disc removal

Extent of removal	Order	Part name	Q'ty	Remarks
	1	Nut (rear wheel axle)	1	Refer to "REMOVAL POINTS".
	2	Rear wheel axle	1	
	3	Rear wheel	1	
	4	Collar	1	
	5	Clutch hub	1	
	6	Driven sprocket	1	Refer to "REMOVAL POINTS".
	7	Bolt (driven sprocket)	3	
	8	Damper	3	
	9	Bearing	2	
	10	Brake disc	1	

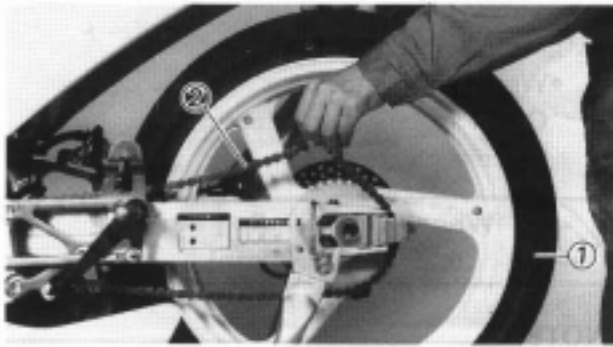

REMOVAL POINTS

Rear wheel

1. Remove:
 - Rear wheel ①

NOTE: _____

Push the rear wheel forward and remove the drive chain ②.

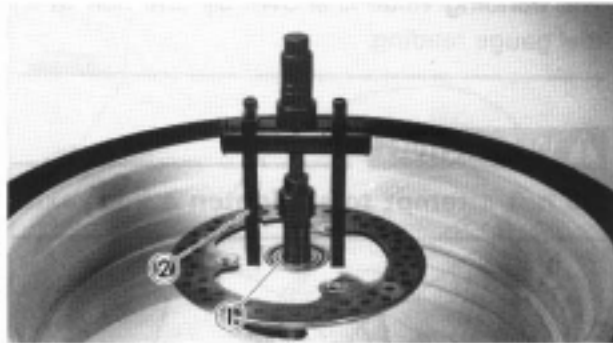

Wheel bearing (if necessary)

1. Remove:
 - Bearing ①

NOTE: _____

Remove the bearing using a general bearing puller ②.

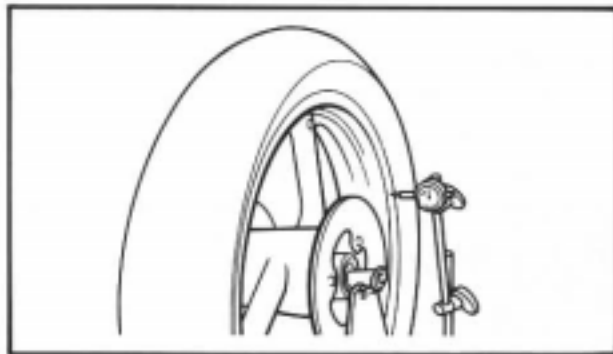

INSPECTION

Rear wheel

1. Measure:
 - Wheel runout

Out of limit → Replace.



Wheel runout limit:

Radial: 1.0 mm (0.04 in)

Lateral: 0.5 mm (0.02 in)

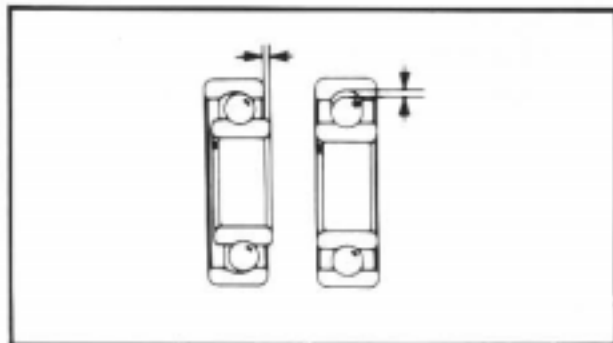

2. Inspect:
 - Bearing

Rotate inner race with a finger.
Rough spot/Seizure → Replace.

NOTE: _____

Replace the bearings and wheel collar as a set.

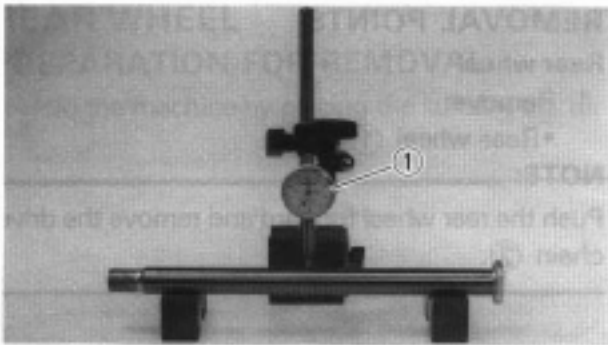

Rear wheel axle

1. Inspect:
 - Wheel axle bends
Out of specification→Replace.
Use dial gauge ①.



Wheel axle bending limit:
0.25 mm (0.010 in)

NOTE:

The bending value is shown by one half of the dial gauge reading.

⚠ WARNING

Do not attempt to straighten a bent axle.

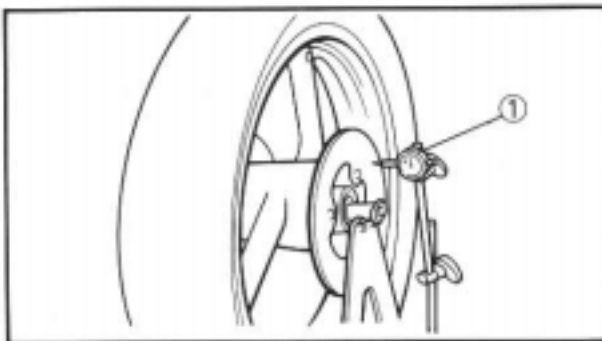

Brake disc

1. Measure:
 - Brake disc deflection
Use dial gauge ①.
Out of specification→Inspect wheel runout.
If wheel runout is in good condition, replace the brake disc.



Disc deflection limit:
0.15 mm (0.006 in)

2. Measure:
 - Brake disc thickness
Use micrometer ①.
Out of limit→Replace.



Disc wear limit:

Standard	Limit
4.0 mm (0.16 in)	3.5 mm (0.14 in)

3. Inspect:
 - Brake disc surface
Score marks/Damage→Replace.

5

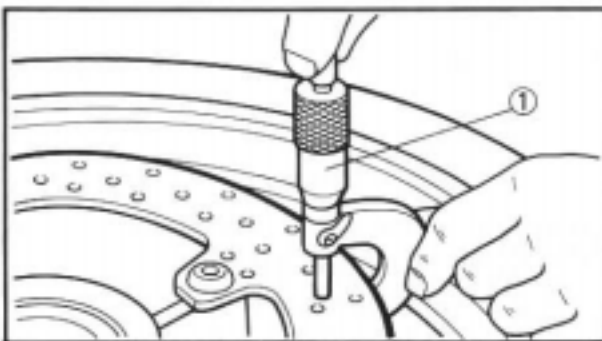

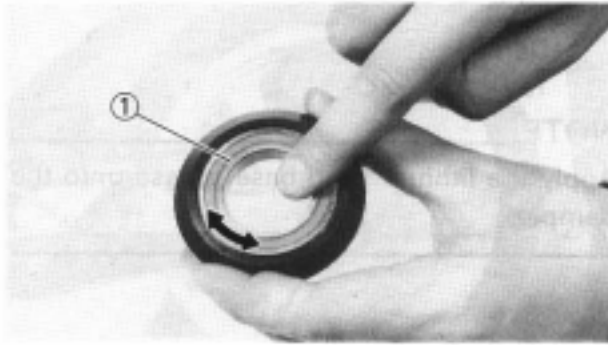

Clutch hub

1. Inspect:
 - Bearing ①
Rotate inner race with a finger.
Rough spot/Seizure→Replace.

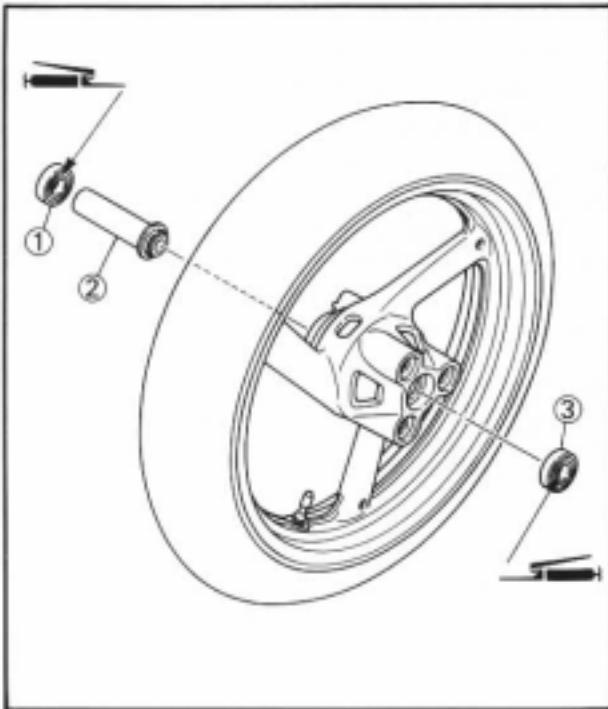

ASSEMBLY AND INSTALLATION

Rear wheel

1. Install:
 - Bearing (right) ①
 - Spacer ②
 - Bearing (left) ③

NOTE:

- Apply the lithium soap base grease on the bearing when installing.
- Use a socket that matches the outside diameter of the race of the bearing.
- Right side of bearing shall be installed first.

CAUTION:

Do not strike the inner race of balls of the bearing. Contact should be made only with the outer race.

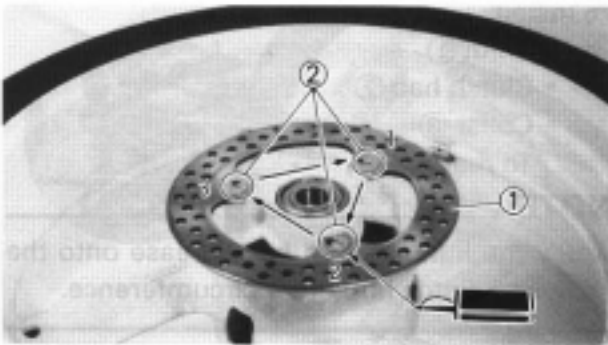

2. Install:
 - Brake disc ①
 - Bolt (brake disc) ②

NOTE:

- Use the T40 bit to tighten the bolts.
- Tighten the bolts in stage, using a crisscross pattern.



Bolt (brake disc):
23 Nm (2.3 m • kg, 17 ft • lb)
LOCTITE®

5

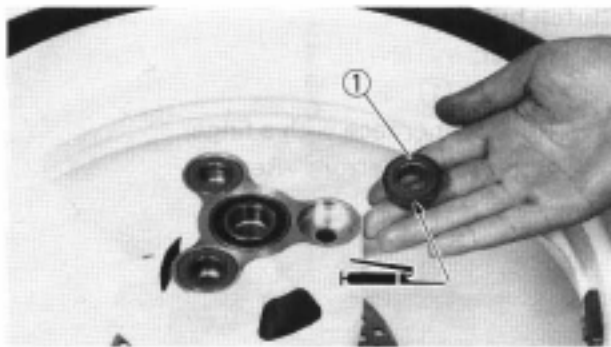

3. Install:
 • Damper ①
 To rear wheel.

NOTE: _____
 Apply the lithium soap base grease onto the damper.

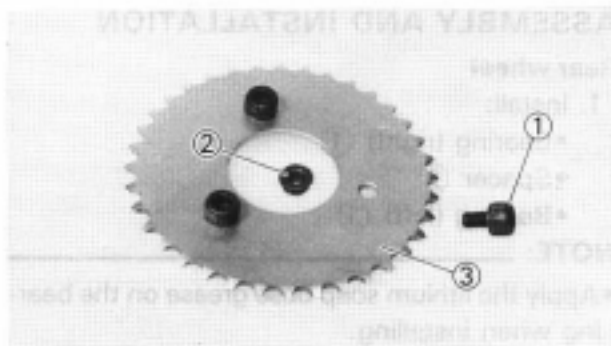

4. Install:
 • Bolt (driven sprocket) ①
 • Nut (driven sprocket) ②
 To driven sprocket ③.

	<p>Nut (sprocket damper): 32 Nm (3.2 m·kg, 23 ft·lb)</p>
--	--

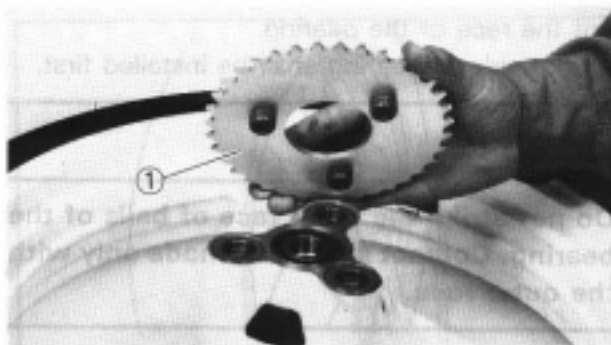

5. Install:
 • Driven sprocket ①
 To rear wheel.

5

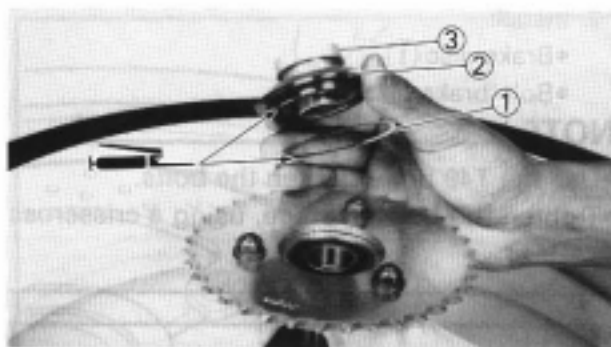

6. Install:
 • Shim ①
 • Clutch hub ②
 • Collar ③
 To rear wheel.

NOTE: _____
 Apply the lithium soap base grease onto the shim and clutch hub outer circumference.

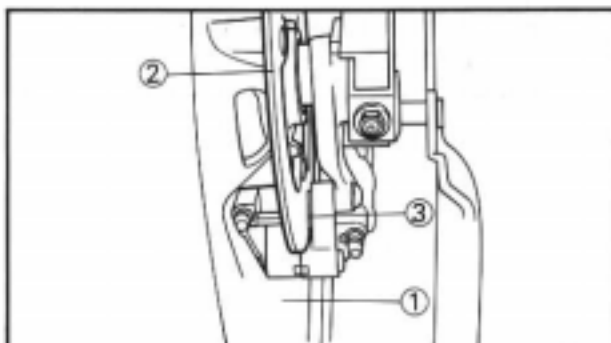

7. Install:
 • Rear wheel ①
- NOTE:** _____
 Install the brake disc ② between the brake pads ③ correctly.

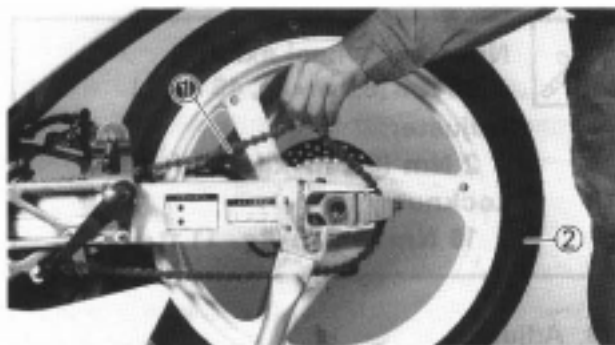

8. Install:

- Drive chain ①

NOTE: _____

Push the rear wheel ② forward and install the drive chain.

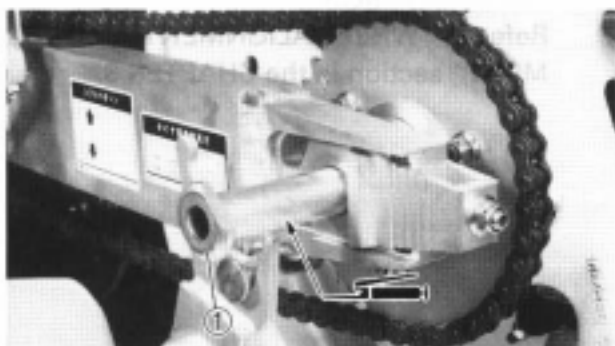

9. Install:

- Rear wheel axle ①

NOTE: _____

- Apply the lithium soap base grease onto the wheel axle.
- Insert the wheel axle from left side.

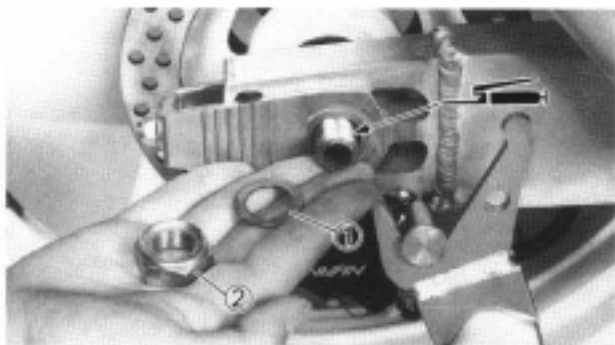

10. Install:

- Plain washer ①
- Nut (rear wheel axle) ②

NOTE: _____

Apply the lithium soap base grease onto the wheel axle thread.



11. Adjust:

- Drive chain slack ①



Drive chain slack ①:
30 ~ 40 mm (1.2 ~ 1.6 in)

Refer to "DRIVE CHAIN SLACK ADJUSTMENT" section in the CHAPTER 3.

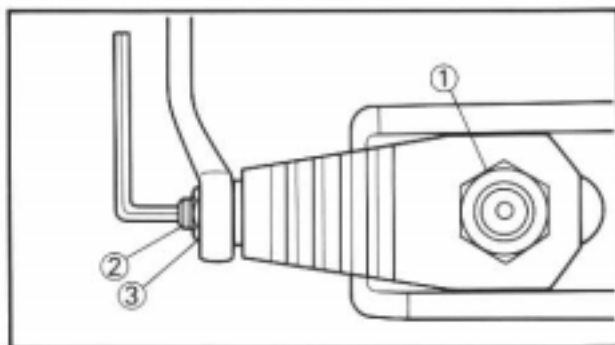

12. Tighten:

- Nut (rear wheel axle) ①
- Adjuster ②
- Locknut ③

NOTE: _____

- Tighten the axle nut while pushing down the drive chain.
- After tightening the axle nut, tighten the locknut with the turned out the adjuster.



Nut (rear wheel axle):

63 Nm (6.3 m•kg, 45 ft•lb)

Adjuster:

2 Nm (0.2 m•kg, 1.4 ft•lb)

Locknut:

16 Nm (1.6 m•kg, 11 ft•lb)

13. Adjust:

- Wheel alignment

Refer to "WHEEL ALIGNMENT ADJUSTMENT" section in the CHAPTER 3.



FRONT BRAKE PREPARATION FOR REMOVAL

- * Hold the machine by placing the suitable stand.
- * Remove the cowling.

⚠ WARNING

Support the machine securely so there is no danger of it falling over.

PAD WEAR LIMIT:

1.0 mm (0.04 in)

A	8 Nm (0.8 m·kg, 5.8 ft·lb)
B	26 Nm (2.6 m·kg, 19 ft·lb)
C	5 Nm (0.5 m·kg, 3.6 ft·lb)
D	6 Nm (0.6 m·kg, 4.3 ft·lb)
E	7 Nm (0.7 m·kg, 5.1 ft·lb)
F	10 Nm (1.0 m·kg, 7.2 ft·lb)
G	35 Nm (3.5 m·kg, 25 ft·lb)
H	14 Nm (1.4 m·kg, 10 ft·lb)
I	1 Nm (0.1 m·kg, 0.7 ft·lb)

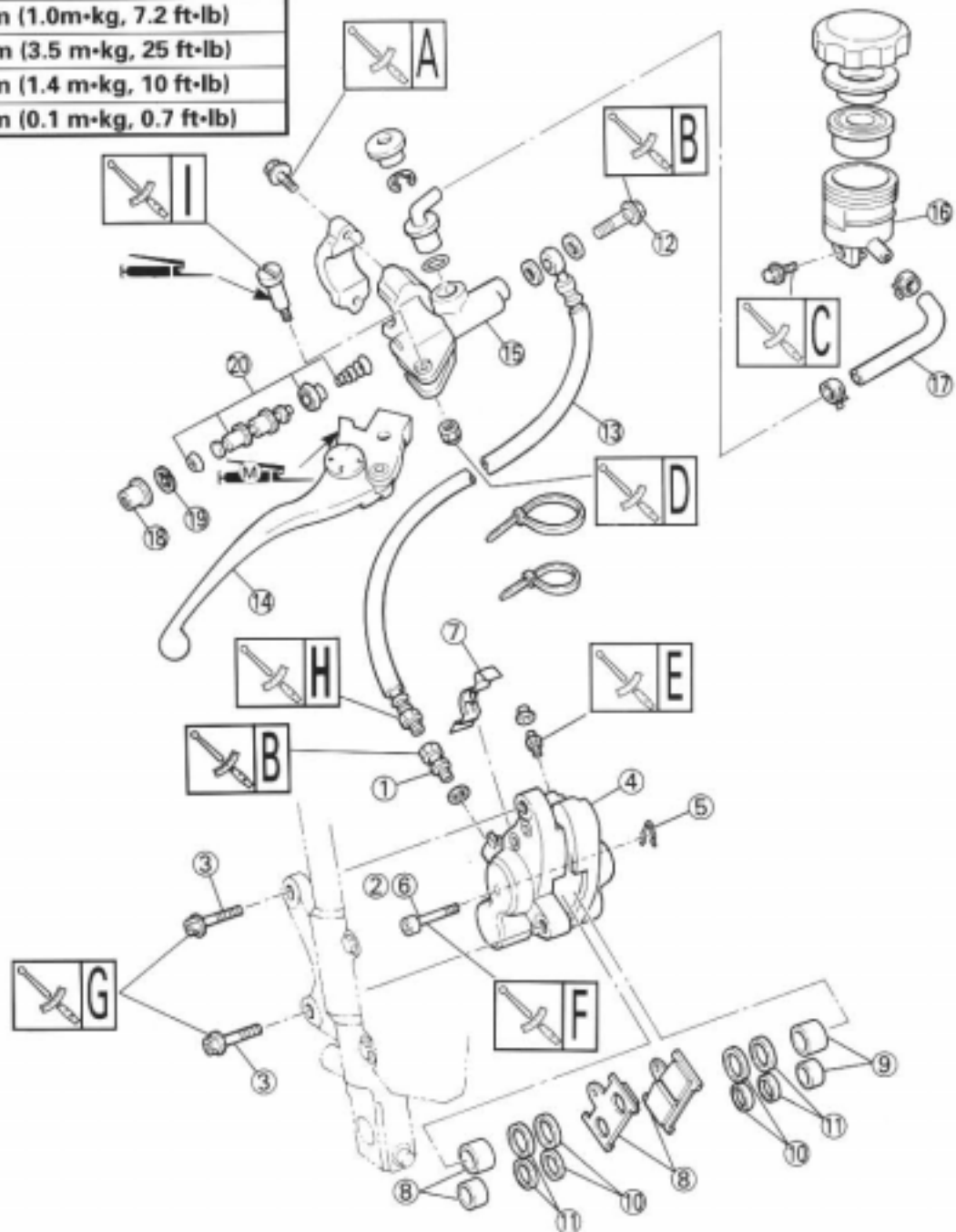

5



CAUTION:

Disc brake components rarely require disassembly. **DO NOT:**

- Disassemble components unless absolutely necessary.
- Use solvents on internal brake component.
- Use contaminated brake fluid for cleaning.
Use only clean brake fluid.
- Allow brake fluid to come in contact with the eyes otherwise eye injury may occur.
- Allow brake fluid to contact painted surfaces or plastic parts otherwise damage may occur.
- Disconnect any hydraulic connection otherwise the entire system must be disassembled, drained, cleaned, and then properly filled and bled after reassembly.

Extent of removal: ① Brake pads removal ② Caliper removal and disassembly
 ③ Master cylinder removal and disassembly ④ Brake hose removal

Extent of removal	Order	Part name	Q'ty	Remarks
	1	Adapter	1	Drain the brake fluid.
	2	Pad pin	1	
	3	Bolt (caliper)	2	Refer to "REMOVAL POINTS".
	4	Caliper	1	
	5	Clip	1	
	6	Pad pin	1	Use low compressed air. Refer to "REMOVAL POINTS".
	7	Pad support	1	
	8	Brake pad	2	
	9	Caliper piston	4	
	10	Dust seal	4	
	11	Piston seal	4	Refer to "REMOVAL POINTS".
	12	Union bolt	1	
	13	Brake hose	1	Drain the brake fluid.
	14	Brake lever	1	
	15	Master cylinder	1	
	16	Reservoir tank	1	Refer to "FRONT WHEEL" section.
	17	Reservoir hose	1	
	18	Master cylinder boot	1	
	19	Circlip	1	
	20	Master cylinder kit	1	

5

⚠ WARNING

The brake components of this machine are suit for closed circuit use only. Never use on any public road.

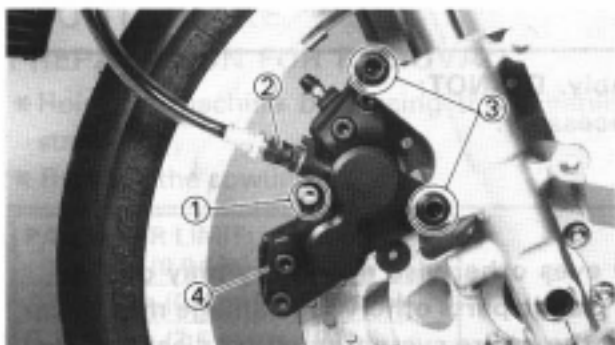

REMOVAL POINTS

Caliper

1. Loosen:
 - Pad pin ①
2. Remove:
 - Adapter ②
 - Bolt (caliper) ③
 - Caliper ④

NOTE:

Loosen the pad pin before removing the caliper from the front fork.

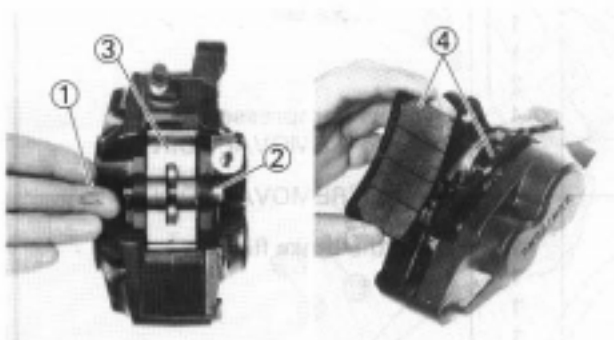

3. Remove:
 - Clip ①
 - Pad pin ②
 - Pad support ③
 - Brake pad ④

5



Caliper piston

1. Remove:
 - Caliper piston

Use compressed air and proceed carefully.

⚠ WARNING

- Cover piston with rag and use extreme caution when expelling piston from cylinder.
- Never attempt to pry out piston.

Caliper piston removal steps:

- Insert a piece of rag into the caliper to lock one caliper.
- Carefully force the piston out of the caliper cylinder with compressed air.

**Piston seal kit**

1. Remove:

- Dust seal ①
- Piston seal ②

NOTE:

Remove the piston and dust seal by pushing it with a finger.

CAUTION:

- Never attempt to pry out piston and dust seals.
- Do not loosen the bolts ③.

⚠ WARNING

Replace the piston and dust seals whenever a caliper is disassembled.

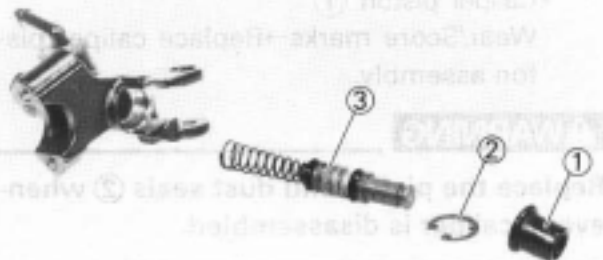
**Master cylinder kit**

1. Remove:

- Master cylinder boot ①
- Circlip ②
- Master cylinder kit ③

NOTE:

When removing the circlip, use a long nose circlip plier.

INSPECTION**Master cylinder**

1. Inspect:

- Master cylinder body ①
Wear/Scratches → Replace master cylinder assembly.
Stains → Clean.

NOTE:

Use new brake fluid.

2. Inspect:

- Diaphragm ①
Crack/Damage → Replace.



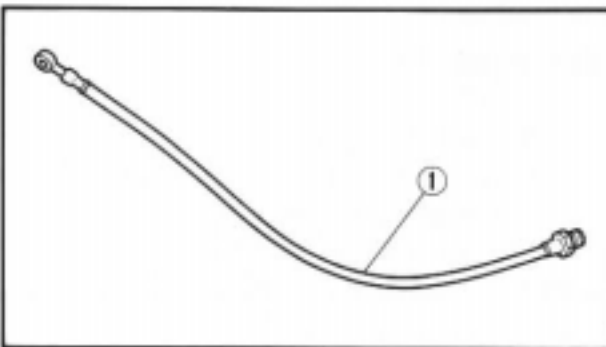
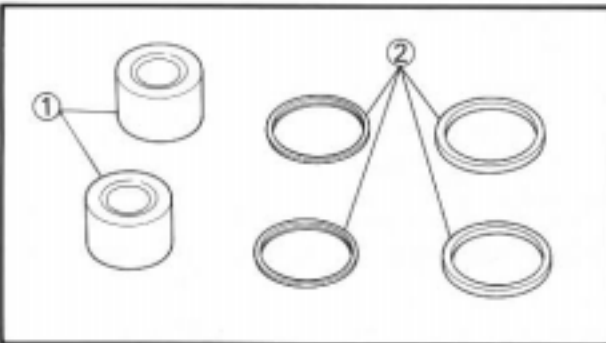
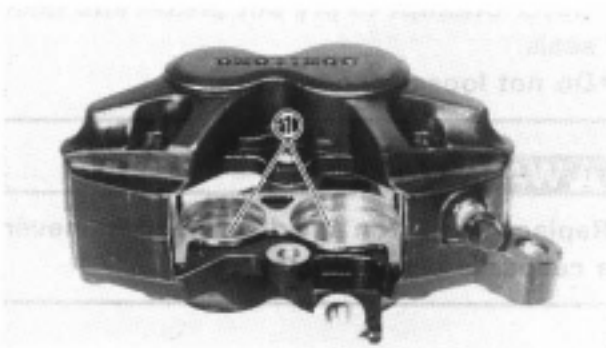
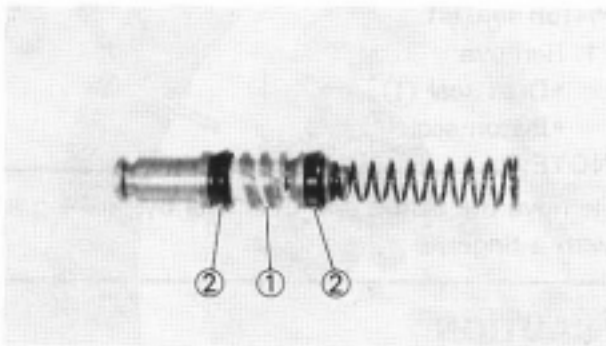

5

3. Inspect:

- Master cylinder piston ①
 - Master cylinder cup ②
- Wear/Damage/Score marks → Replace master cylinder kit.

NOTE:

Replace master cylinder piston and cup as a set.

Caliper

1. Inspect:

- Caliper cylinder ①
- Wear/Score marks → Replace caliper assembly.

2. Inspect:

- Caliper piston ①
- Wear/Score marks → Replace caliper piston assembly.

WARNING

Replace the piston and dust seals ② whenever a caliper is disassembled.

Brake hose

1. Inspect:

- Brake hose ①
- Crack/Damage → Replace.

ASSEMBLY AND INSTALLATION

WARNING

- All internal parts should be cleaned in new brake fluid only.
- Internal parts should be lubricated with brake fluid when installed.
- Replace the piston seal and dust seal whenever a caliper is disassembled.

Caliper piston

- Clean:
 - Caliper
 - Piston seal
 - Dust seal
 - Caliper piston
 Clean them with brake fluid.

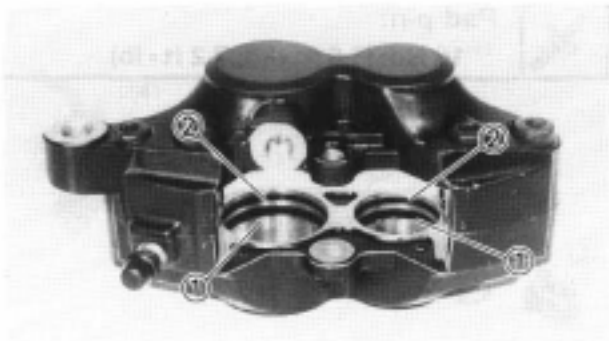

- Install:
 - Piston seal ①
 - Dust seal ②

NOTE: _____
 Fit the piston and dust seal onto the slot on caliper correctly.

▲WARNING _____
 Always use new piston and dust seals.

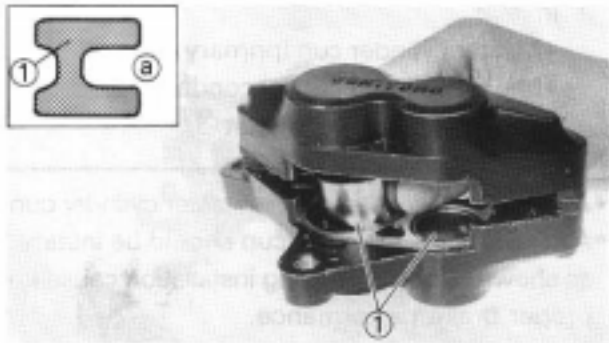

- Install:
 - Caliper piston ①

NOTE: _____
 Apply the brake fluid on the piston wall.

CAUTION: _____
 • Be sure that the shallow depressed side (a) face the caliper side.
 • Never force to insert.

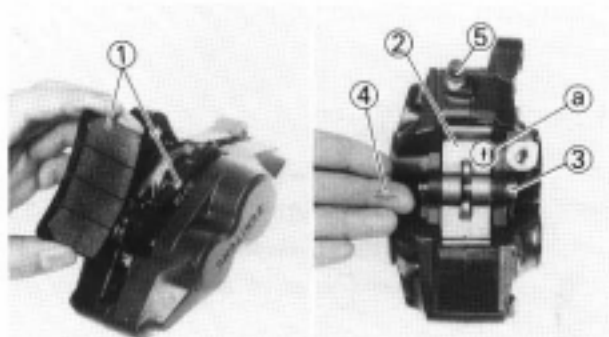
**Caliper**

- Install:
 - Brake pad ①
 - Pad support ②
 - Pad pin ③
 - Clip ④

NOTE: _____
 • Install the pad support with its arrow mark (a) facing the bleed screw (5).
 • Temporarily tighten the pad pin at this point.

5

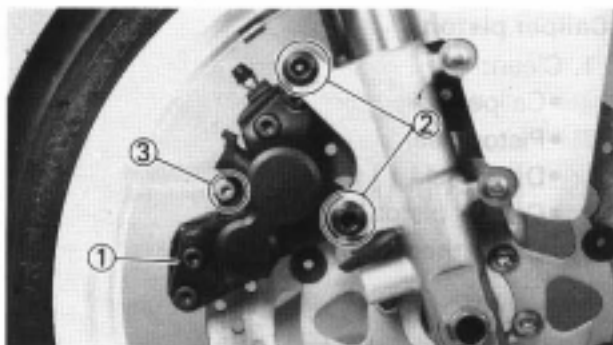

2. Install:

- Caliper ①
- Bolt (caliper) ②

**Bolt (caliper):****35 Nm (3.5 m•kg, 25 ft•lb)**

3. Tighten:

- Pad pin ③

**Pad pin:****10 Nm (1.0 m•kg, 7.2 ft•lb)****Master cylinder kit**

1. Clean:

- Master cylinder
 - Master cylinder kit
- Clean them with brake fluid.

2. Install:

- Master cylinder cup (primary) ①
 - Master cylinder cup (secondary) ②
- To master cylinder piston ③.

NOTE:

- Apply the brake fluid on the master cylinder cup.
- After installing, cylinder cup should be installed as shown direction. Wrong installation cause improper brake performance.

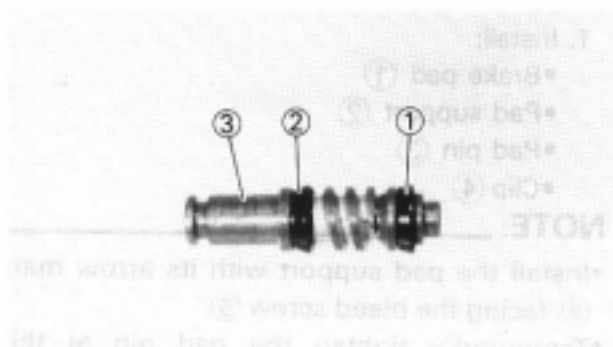
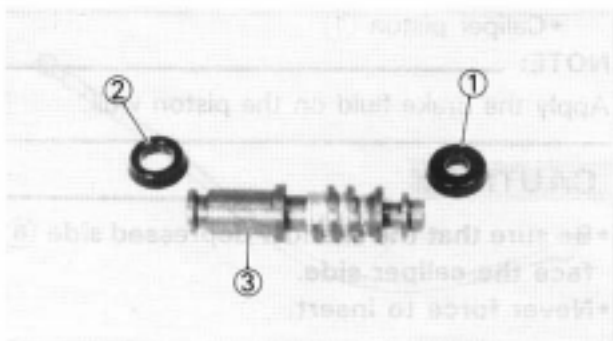
5



3. Install:

- Spring ①
- To master cylinder piston ②.

NOTE:

Install the spring at the smaller dia. side.



4. Install:

- Master cylinder kit ①
- Circlip ②
- Master cylinder boot ③
- To master cylinder ④.

NOTE:

- Apply the brake fluid on the master cylinder kit.
- When installing the circlip, use a long nose circlip plier.

Master cylinder

1. Install:

- Reservoir tank ①
- Bolt (reservoir tank) ②
- Reservoir hose ③



Bolt (reservoir tank):

5 Nm (0.5 m • kg, 3.6 ft • lb)

2. Install:

- Master cylinder ①
- Master cylinder bracket ②
- Bolt (master cylinder bracket) ③

NOTE:

- Install the bracket so that the arrow mark (a) face upward.
- When installing master cylinder, align the contacting surface (b) of the master cylinder bracket with the punch mark (c) on the handlebar.



Bolt (master cylinder bracket):

8 Nm (0.8 m • kg, 5.8 ft • lb)

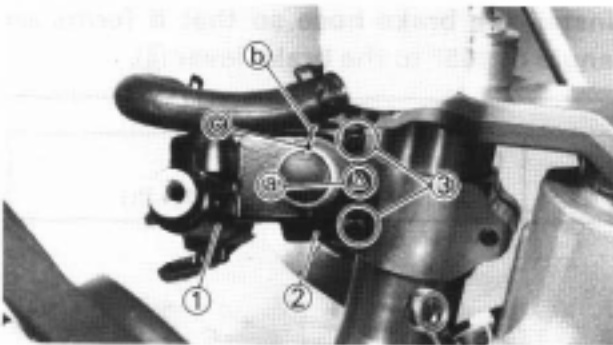
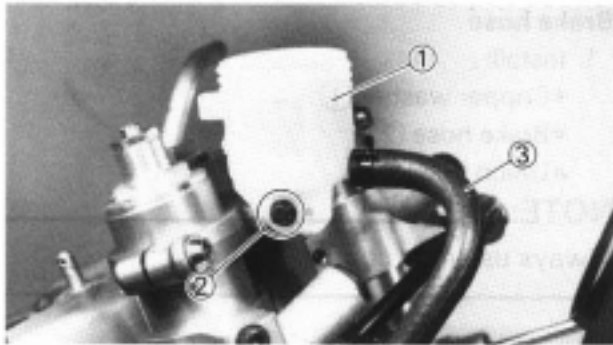

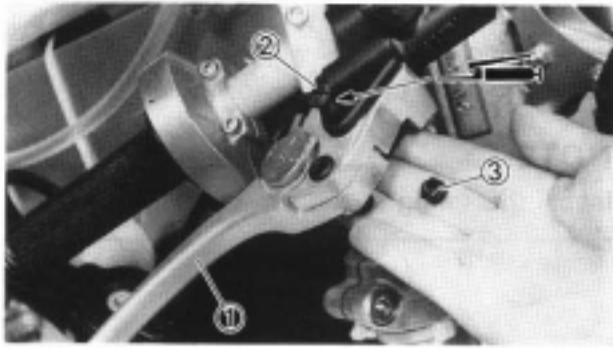

3. Install:

- Brake lever ①
- Bolt (brake lever) ②
- Nut (brake lever) ③

NOTE:

- Apply the lithium soap base grease on the bolt.
- When installing the brake lever, apply the molybdenum disulfide grease on the contacting surface of the master cylinder piston.

**Bolt (brake lever):**

1 Nm (0.1 m•kg, 0.7 ft•lb)

Nut (brake lever):

6 Nm (0.6 m•kg, 4.3 ft•lb)

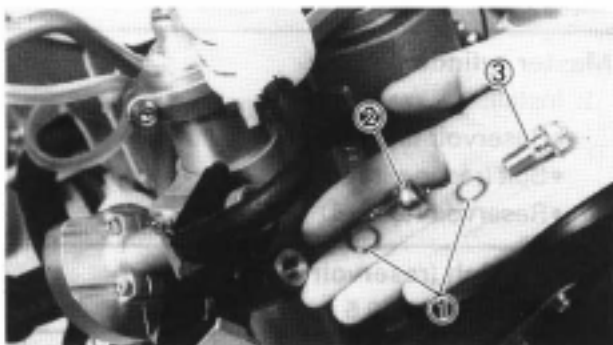
**Brake hose**

1. Install:

- Copper washer ①
- Brake hose ②
- Union bolt ③

NOTE:

Always use new copper washers.

CAUTION:

Install the brake hose so that it forms an angle of 105° to the brake lever ④.

**Union bolt:**

26 Nm (2.6 m•kg, 19 ft•lb)

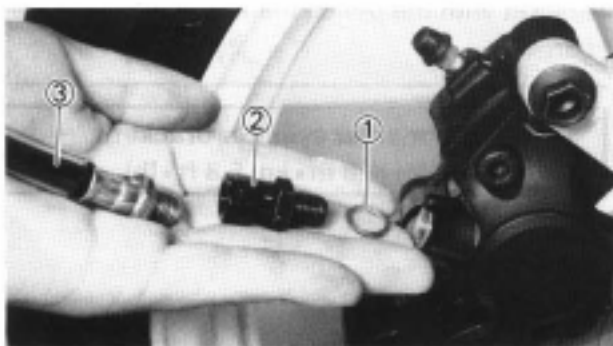
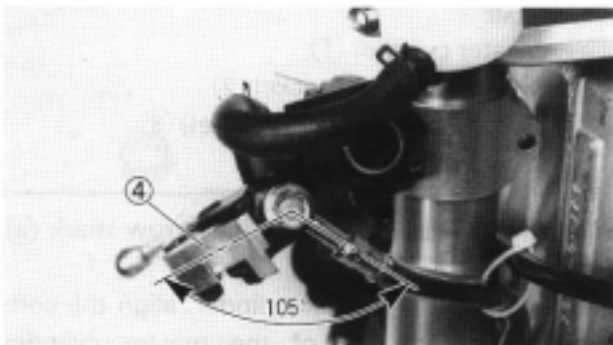
5

2. Install:

- Copper washer ①
- Adapter ②
- Brake hose ③

NOTE:

- Always use a new copper washer.
- When turning the adapter over the brake hose, hold the brake hose so that it may not be twisted.

**Adapter:**

26 Nm (2.6 m•kg, 19 ft•lb)

Brake hose:

14 Nm (1.4 m•kg, 10 ft•lb)

Brake fluid

1. Fill:

- Brake fluid

**Recommended brake fluid:**

DOT #4

NOTE:

If DOT #4 is not available, #3 can be used.

CAUTION:

Brake fluid may erode painted surfaces or plastic parts. Always clean up spilled fluid immediately.

WARNING

- Use only the designated quality brake fluid; otherwise, the rubber seals may deteriorate, causing leakage and poor brake performance.
- Refill with the same type of brake fluid; mixing fluids may result in a harmful chemical reaction and lead to poor performance.
- Be careful that water does not enter the master cylinder when refilling. Water will significantly lower the boiling point of the fluid and may result in vapor lock.

5

2. Air bleed:

- Brake system

Refer to "BRAKE SYSTEM AIR BLEEDING" section in the CHAPTER 3.

**REAR BRAKE
PREPARATION FOR REMOVAL**

* Hold the machine by placing the suitable stand.

⚠ WARNING

Support the machine securely so there is no danger of it falling over.

* Remove the seat.

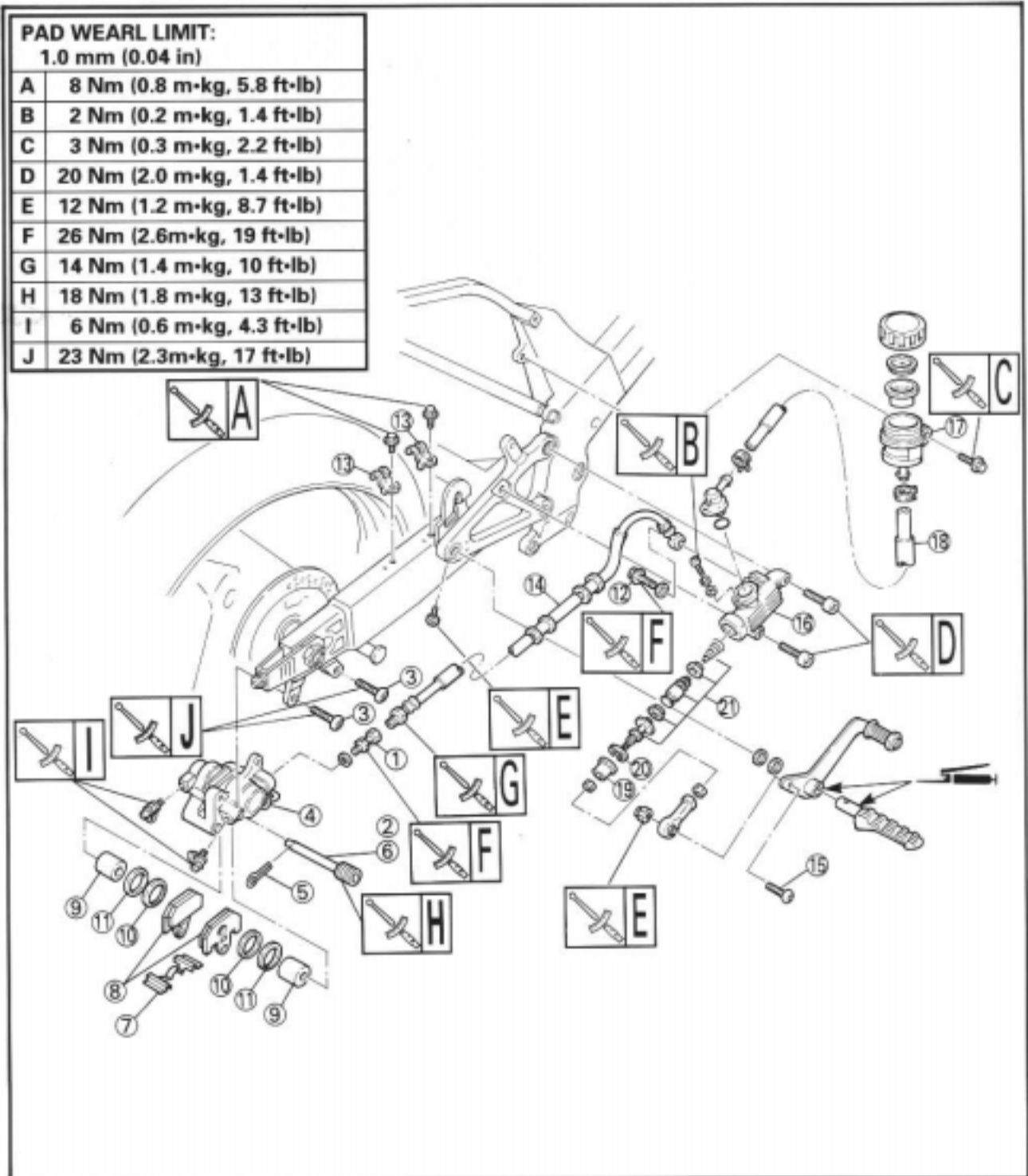



CAUTION:

Disc brake components rarely require disassembly. **DO NOT:**

- Disassemble components unless absolutely necessary.
- Use solvents on internal brake component.
- Use contaminated brake fluid for cleaning.
Use only clean brake fluid.
- Allow brake fluid to come in contact with the eyes otherwise eye injury may occur.
- Allow brake fluid to contact painted surfaces or plastic parts otherwise damage may occur.
- Disconnect any hydraulic connection otherwise the entire system must be disassembled, drained, cleaned, and then properly filled and bled after reassembly.

Extent of removal: ① Brake pad removal ② Caliper removal and disassembly
 ③ Master cylinder removal and disassembly ④ Brake hose removal

Extent of removal	Order	Part name	Q'ty	Remarks	
	1	Adapter	1	Drain the brake fluid. Only loosening.	
	2	Pad pin	1		
	3	Bolt (caliper)	2		
	4	Caliper	1		
	5	Cotter pin	1		
		6	Pad pin	1	Refer to "REMOVAL POINTS".
		7	Pad support	1	
		8	Brake pad	2	
		9	Caliper piston	2	
		10	Dust seal	2	Use low compressed air. Refer to "REMOVAL POINTS".
		11	Piston seal	2	Refer to "REMOVAL POINTS".
		12	Union bolt	1	
		13	Brake hose holder	2	Drain the brake fluid.
		14	Brake hose	1	
		15	Brake pedal connecting bolt	1	
		16	Master cylinder	1	Refer to "REMOVAL POINTS".
		17	Reservoir tank	1	
		18	Reservoir hose	1	
		19	Master cylinder boot	1	
		20	Circlip	1	
		21	Master cylinder kit	1	

5

⚠ WARNING

The brake components of this machine are suit for closed circuit use only. Never use on any public road.

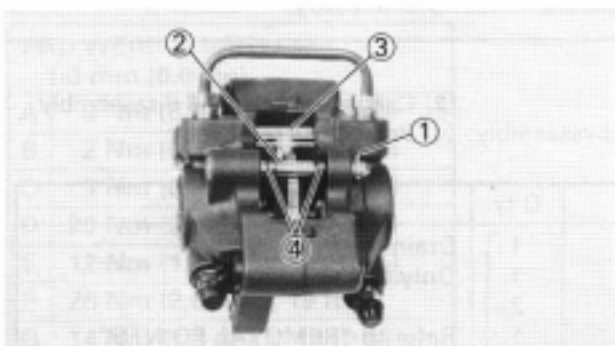
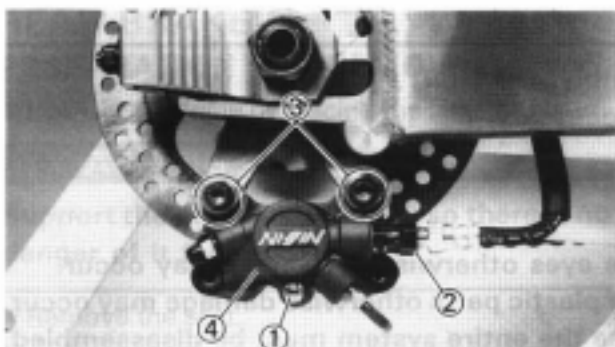

REMOVAL POINTS

Caliper

- Loosen:
 - Pad pin ①
- Remove:
 - Adapter ②
 - Bolt (caliper) ③
 - Caliper ④

NOTE:

Loosen the pad pin before removing the caliper from the swingarm.

- Remove:
 - Cotter pin ①
 - Pad pin ②
 - Pad support ③
 - Brake pad ④

Caliper piston

- Remove:
 - Caliper piston

Use compressed air and proceed carefully.

⚠ WARNING

- Cover piston with rag and use extreme caution when expelling piston from cylinder.
- Never attempt to pry out piston.

Caliper piston removal steps:

- Insert a piece of rag into the caliper to lock one caliper.
- Carefully force the piston out of the caliper cylinder with compressed air.

Piston seal kit

- Remove:
 - Dust seal ①
 - Piston seal ②

NOTE:

Remove the piston and dust seal by pushing it with a finger.

CAUTION:

- Never attempt to pry out piston and dust seals.
- Do not loosen the bolts ③.

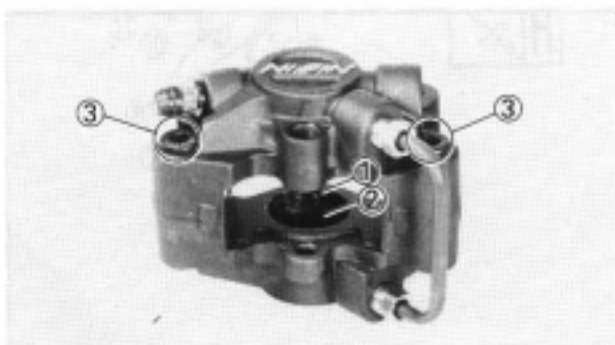

5

⚠ WARNING

Replace the piston seals whenever a caliper is disassembled.

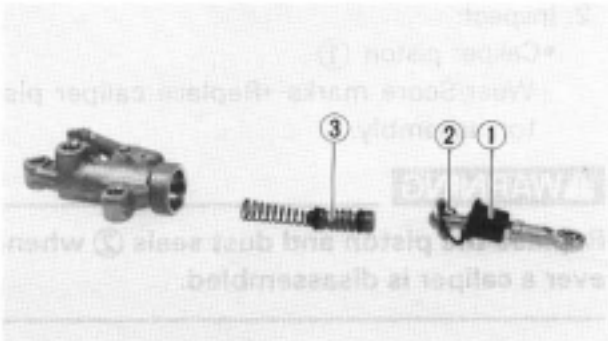
**Master cylinder kit**

- Remove:
 - Master cylinder boot (1)
 - Circlip (2)
 - Master cylinder kit (3)

NOTE:

When removing the circlip, use a long nose circlip plier.

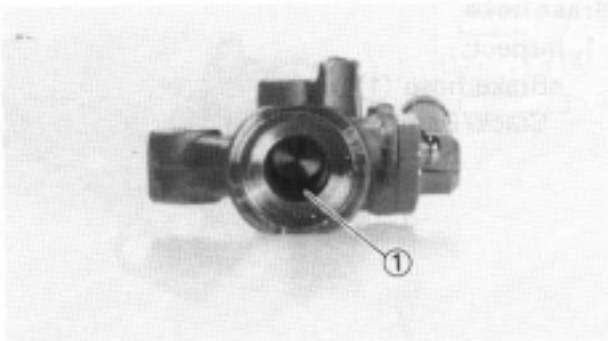
**INSPECTION****Master cylinder**

- Inspect:
 - Master cylinder body (1)
Wear/Scratches → Replace master cylinder assembly.
Stains → Clean.

NOTE:

Use new brake fluid.



- Inspect:
 - Diaphragm (1)
Crack/Damage → Replace.

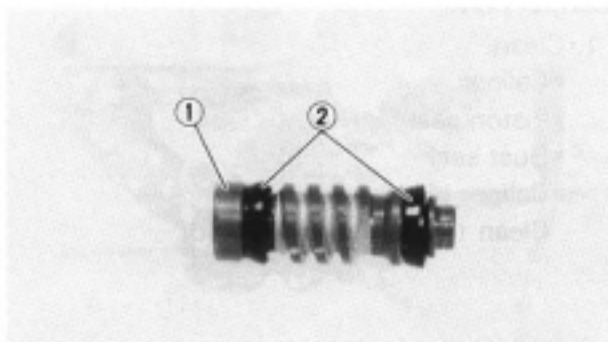

- Inspect:
 - Master cylinder piston (1)
 - Master cylinder cup (2)
Wear/Damage/Score marks → Replace master cylinder kit.

NOTE:

Replace master cylinder piston and cup as a set.



Caliper

1. Inspect:

- Caliper cylinder ①
Wear/Score marks → Replace caliper assembly.

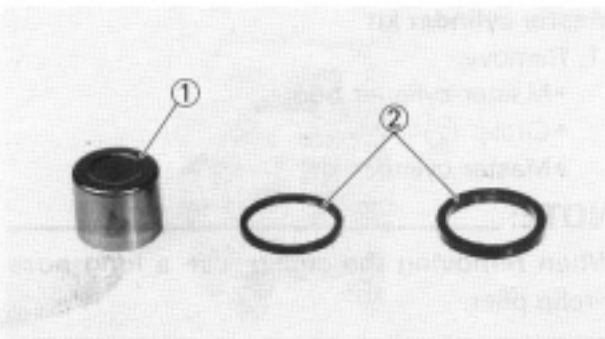

2. Inspect:

- Caliper piston ①
Wear/Score marks → Replace caliper piston assembly.

▲WARNING

Replace the piston and dust seals ② whenever a caliper is disassembled.

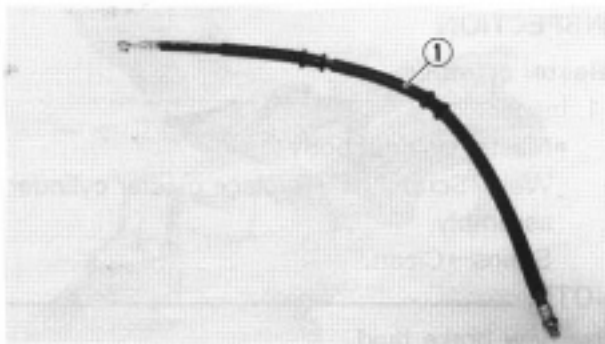

Brake hose

1. Inspect:

- Brake hose ①
Crack/Damage → Replace.

5

ASSEMBLY AND INSTALLATION

▲WARNING

- All internal parts should be cleaned in new brake fluid only.
- Internal parts should be lubricated with brake fluid when installed.
- Replace the piston seal and dust seal whenever a caliper is disassembled.

Caliper piston

1. Clean:

- Caliper
- Piston seal
- Dust seal
- Caliper piston
Clean them with brake fluid.

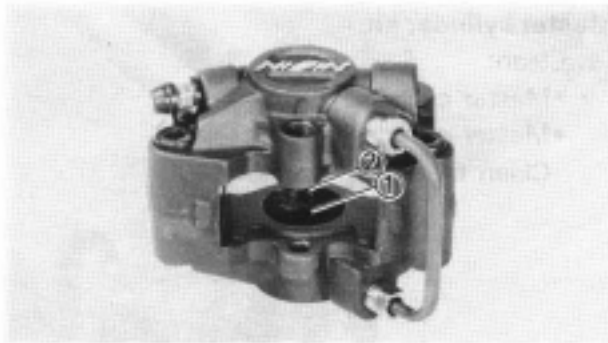
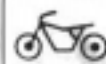

2. Install:

- Piston seal ①
- Dust seal ②

NOTE:

Fit the piston and dust seal onto the slot on caliper correctly.

WARNING

Always use new piston and dust seals.

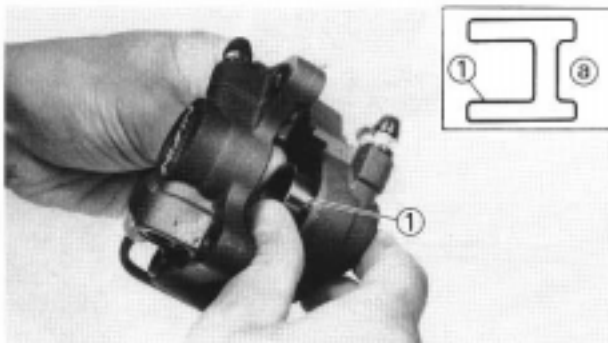

3. Install:

- Caliper piston ①

NOTE:

Apply the brake fluid on the piston wall.

CAUTION:

- Be sure that the shallow depressed side ① face the caliper side.
- Never force to insert.

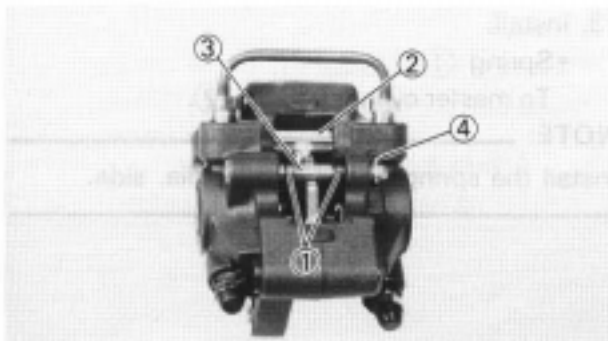
**Caliper**

1. Install:

- Brake pad ①
- Pad support ②
- Pad pin ③
- Cotter pin ④

NOTE:

- Always use a new cotter pin.
- Temporarily tighten the pad pin at this point.

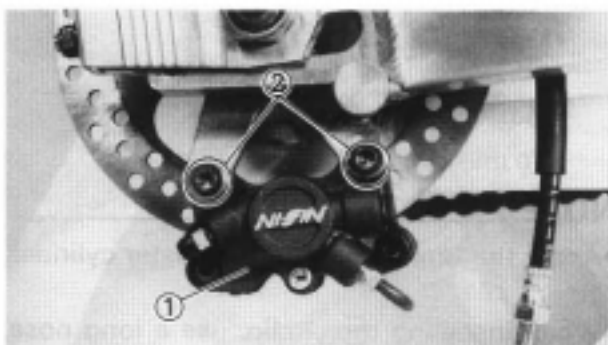

2. Install:

- Caliper ①
- Bolt (caliper) ②



Bolt (caliper):

23 Nm (2.3 m•kg, 17 ft•lb)

5

**Master cylinder kit****1. Clean:**

- Master cylinder
 - Master cylinder kit
- Clean them with brake fluid.

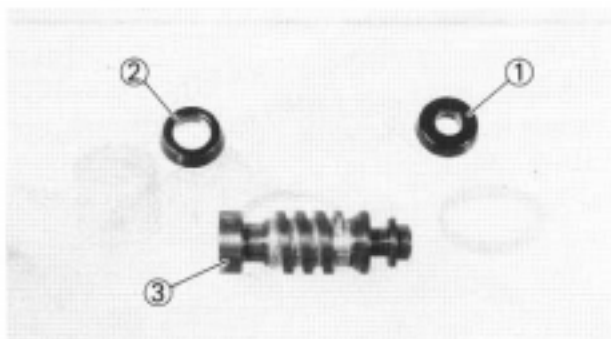
**2. Install:**

- Master cylinder cup (primary) ①
 - Master cylinder cup (secondary) ②
- To master cylinder piston ③.

NOTE:

- Apply the brake fluid on the master cylinder cup.
- After installing, cylinder cup should be installed as shown direction. Wrong installation cause improper brake performance.

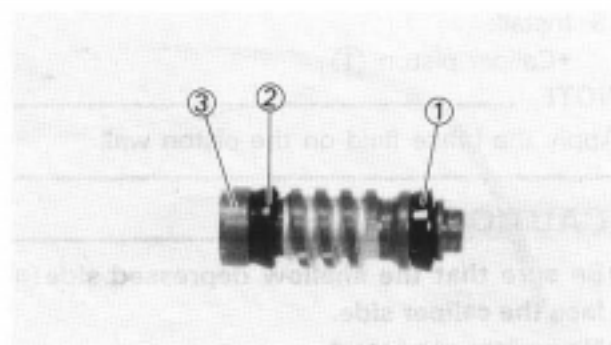
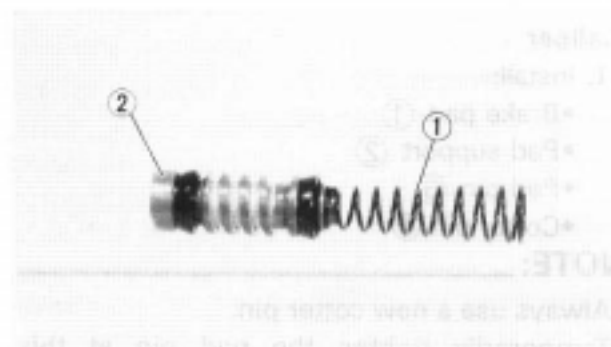
**5****3. Install:**

- Spring ①
- To master cylinder piston ②.

NOTE:

Install the spring at the smaller dia. side.

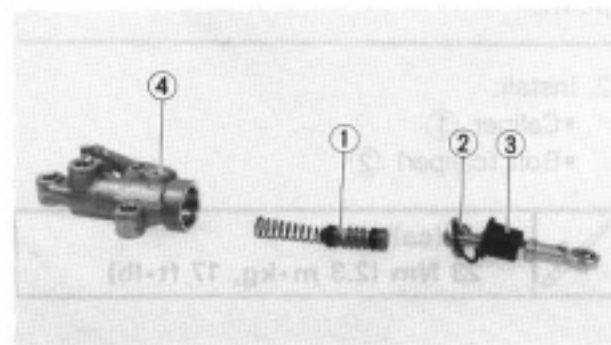
**4. Install:**

- Master cylinder kit ①
 - Circlip ②
 - Master cylinder boot ③
- To master cylinder ④.

NOTE:

- Apply the brake fluid on the master cylinder kit.
- When installing the circlip, use a long nose circlip pliers.

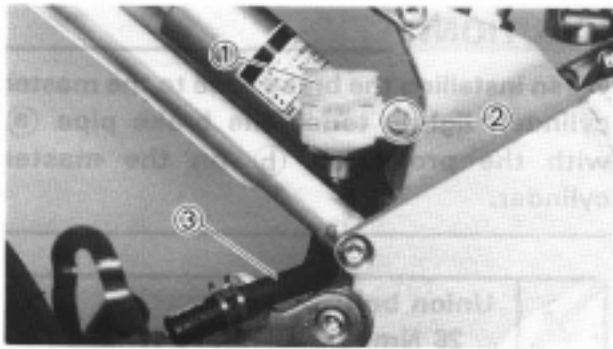
**Master cylinder**

1. Install:

- Reservoir tank ①
- Bolt (reservoir tank) ②
- Reservoir hose ③



Bolt (reservoir tank):
3 Nm (0.3 m•kg, 2.2 ft•lb)

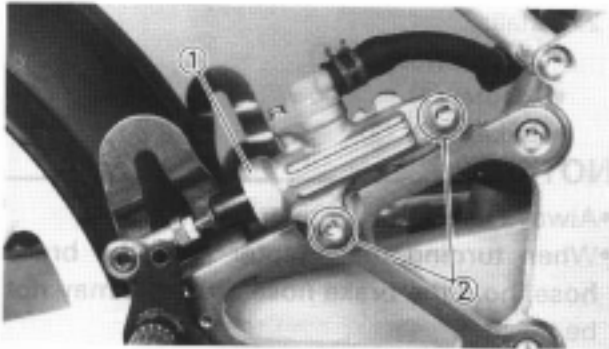

2. Install:

- Master cylinder ①
- Bolt (master cylinder) ②



Bolt (master cylinder):
20 Nm (2.0 m•kg, 14 ft•lb)

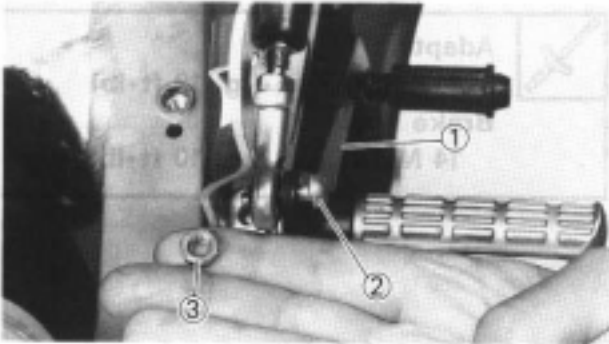

3. Install:

- Brake pedal ①
- Brake pedal connecting bolt ②
- Nut (brake pedal connecting bolt) ③



Nut (brake pedal connecting bolt):
12 Nm (1.2 m•kg, 8.7 ft•lb)

NOTE:

After installing, check the brake pedal height. Refer to "REAR BRAKE ADJUSTMENT" section in the CHAPTER 3.

5

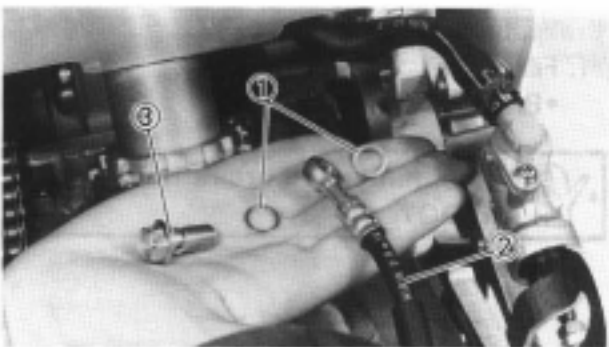
**Brake hose**

1. Install:

- Copper washer ①
- Brake hose ②
- Union bolt ③

NOTE:

Always use new copper washers.

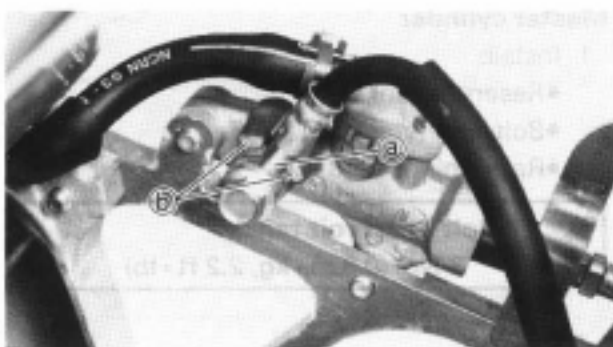
**CAUTION:**

When installing the brake hose to the master cylinder, lightly touch the brake pipe **a** with the projection **b** on the master cylinder.

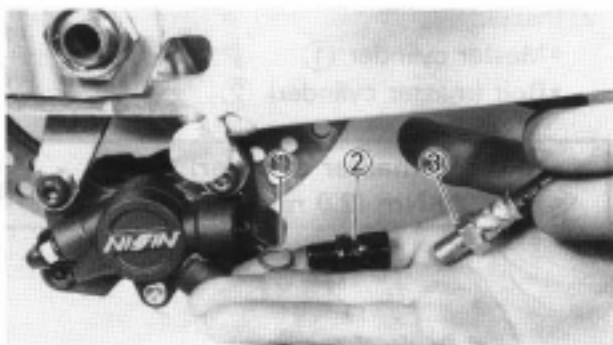

Union bolt:
26 Nm (2.6 m•kg, 19 ft•lb)

2. Install:

- Copper washer **1**
- Adapter **2**
- Brake hose **3**

NOTE:

- Always use a new copper washer.
- When turning the adapter over the brake hose, hold the brake hose so that it may not be twisted.



Adapter:
26 Nm (2.6 m•kg, 19 ft•lb)

Brake hose:
14 Nm (1.4 m•kg, 10 ft•lb)

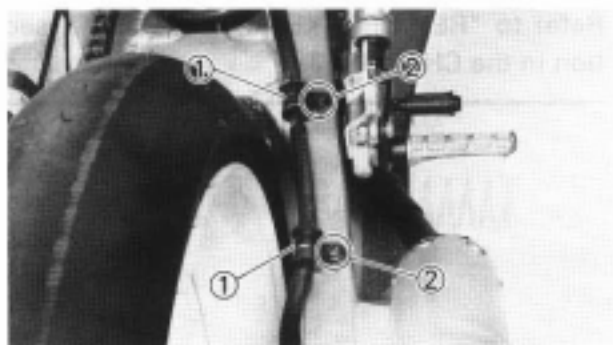
5

3. Install:

- Brake hose holder **1**
- Bolt (brake hose holder) **2**



Bolt (brake hose holder):
8 Nm (0.8 m•kg, 5.8 ft•lb)

Brake fluid

1. Fill:

- Brake fluid



Recommended brake fluid:
DOT #4



FRONT FORK PREPARATION FOR REMOVAL

* Hold the machine by placing the suitable stand.

⚠ WARNING

Support the machine securely so there is no danger of it falling over.

* Remove the following parts:

- Cowling
- Front brake caliper
- Front wheel
- Band (Brake hose clamp)

FORK OIL (EACH FORK) CAPACITY:
282 cm³ (9.9 Imp oz, 9.5 US oz)

RECOMMENDED OIL:
Suspension oil "01"

FORK OIL LEVEL

STANDARD	110 mm (4.33 in)
MINIMUM	140 mm (5.51 in)
MAXIMUM	80 mm (3.15 in)

From top of outer tube with inner tube and damper rod fully compressed without spring.

MINIMUM FORK SPRING FREE LENGTH: 193 mm (7.60 in)

INNER TUBE BENDING LIMIT:
0.2 mm (0.008 in)

A 15 Nm (1.5 m·kg, 11 ft·lb)

B 23 Nm (2.3 m·kg, 17 ft·lb)

C 40 Nm (4.0 m·kg, 29 ft·lb)

D 20 Nm (2.0 m·kg, 14 ft·lb)

E 8 Nm (0.8 m·kg, 5.8 ft·lb)

F 7 Nm (0.7m·kg, 5.1 ft·lb)

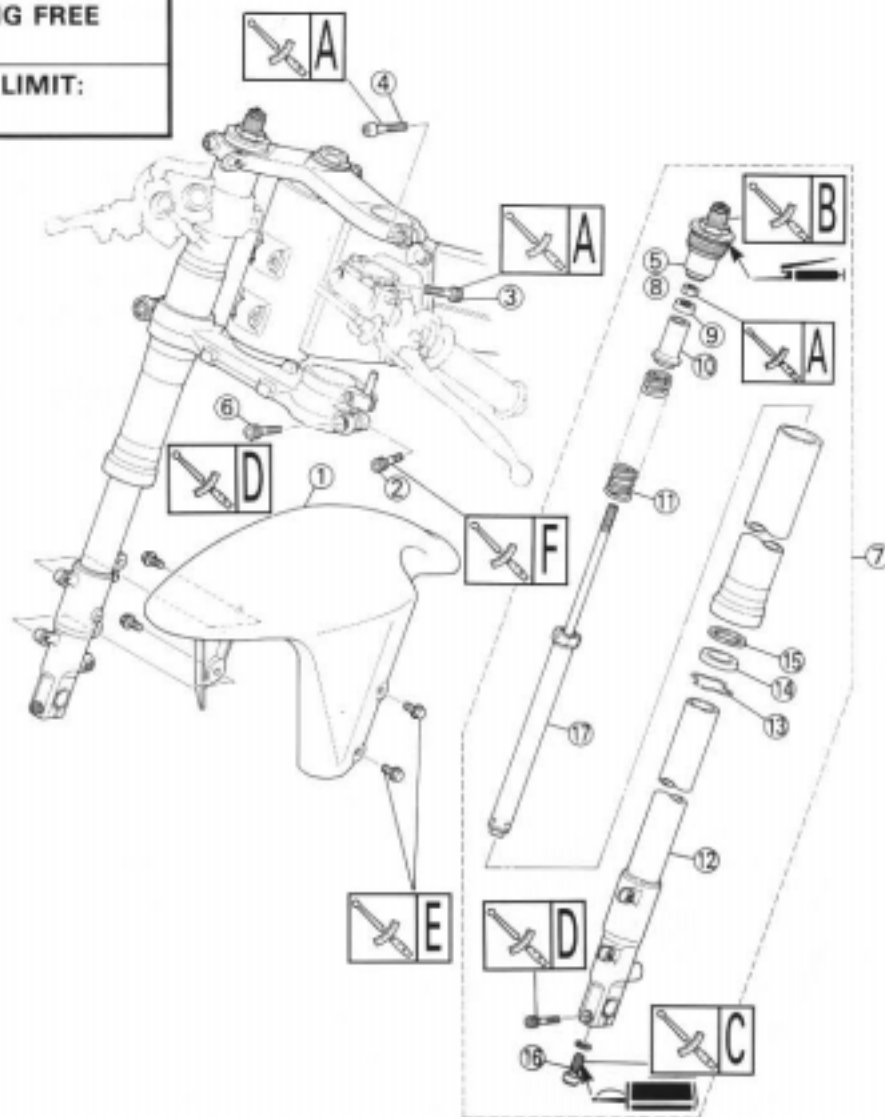

5



Extent of removal: ① Front fork removal ② Oil seal removal ③ Front fork disassembly

Extent of removal	Order	Part name	Q'ty	Remarks
	1	Front fender	1	
	2	Pinch bolt (steering damper stay)	1	Only loosening. (left side only)
	3	Pinch bolt (handle bracket)	1	Only loosening.
	4	Pinch bolt (handle crown)	1	Only loosening.
	5	Cap bolt	1	Only loosening.
	6	Pinch bolt (under bracket)	1	Only loosening.
	7	Front fork	1	
	8	Cap bolt	1	Use special tool. Refer to "REMOVAL POINTS".
	9	Spacer guide	1	
	10	Spacer	1	
	11	Fork spring	1	Drain the fork oil.
	12	Inner tube	1	Refer to "REMOVAL POINTS".
	13	Stopper ring	1	
	14	Oil seal	1	
	15	Oil seal washer	1	
	16	Bolt (damper rod)	1	Use special tool. Refer to "REMOVAL POINTS".
	17	Damper rod	1	

HANDLING NOTE

NOTE:

The front fork requires careful attention. So it is recommended that the front fork be maintained at the dealers.

CAUTION:

To prevent an accidental explosion of air, the following instructions should be observed:

- The front fork with a built-in piston rod has a very sophisticated internal construction and is particularly sensitive to foreign material.

Use enough care not to allow any foreign material to come in when the oil is replaced or when the front fork is disassembled and reassembled.

- Before removing the cap bolts or front forks, be sure to extract the air from the air chamber completely.

5

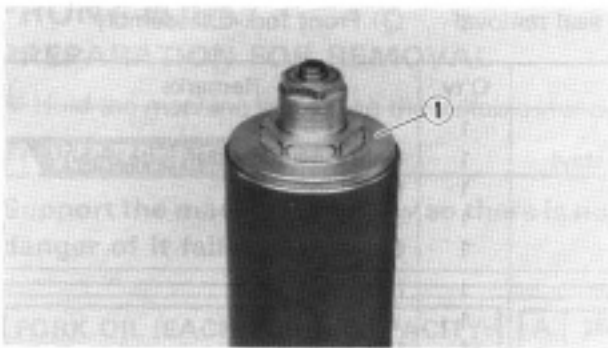

REMOVAL POINTS

Cap bolt

1. Remove:
 - Cap bolt (1)
 From the outer tube.

NOTE:

Before removing the front fork from the machine, loosen the cap bolt.

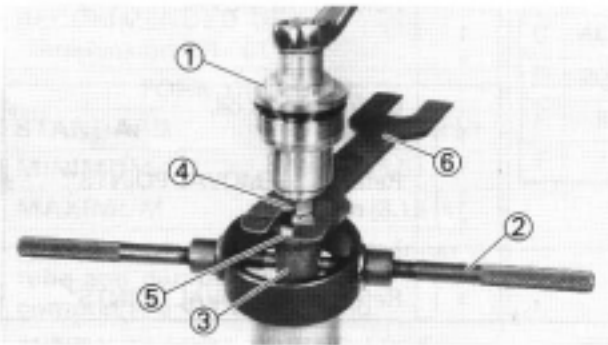

2. Remove:
 - Cap bolt (1)

NOTE:

- While pressing down the spacer (3) with fork spring compressor (2), set the rod holder (6) between the locknut (4) and spacer guide (5).
- Hold the locknut and remove the cap bolt.



Fork spring compressor:

YM-01441/90890-01441

Rod holder:

YM-01434/90890-01434

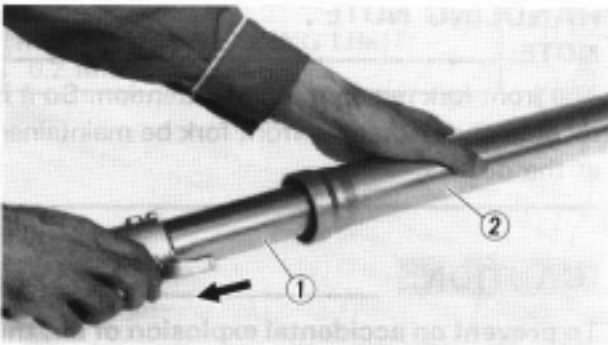

Oil seal

1. Remove:
 - Inner tube (1)
 Pull out the inner tube from the outer tube (2).
2. Remove:
 - Stopper ring (1)
 Using slotted-head screwdriver.

CAUTION:

Take care not to scratch the outer tube.

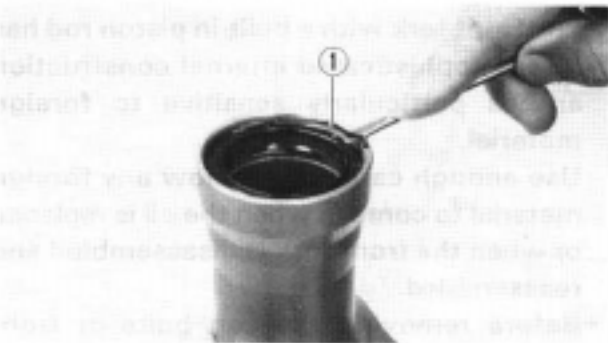

3. Remove:
 - Oil seal (1)
 Using slotted-head screwdriver.

CAUTION:

- Take care not to scratch the outer tube inner surface.
- Replace the oil seal whenever removed.

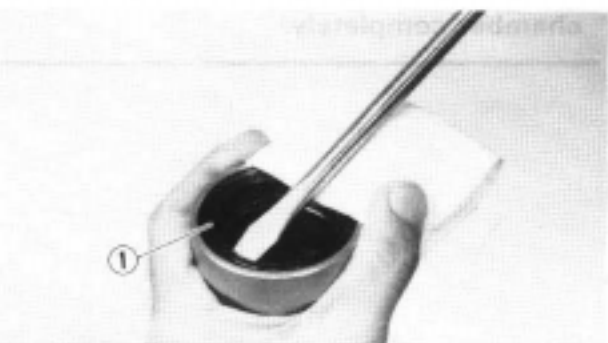

5

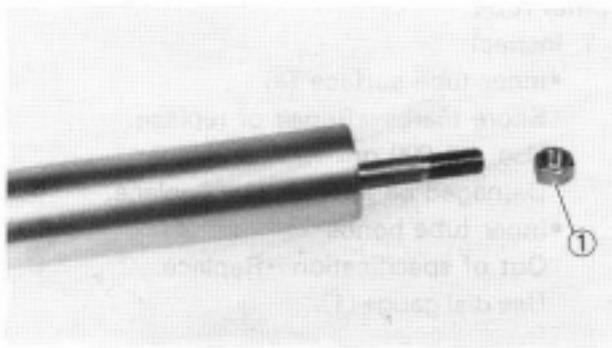

Damper rod

1. Remove:
 - Locknut (1)

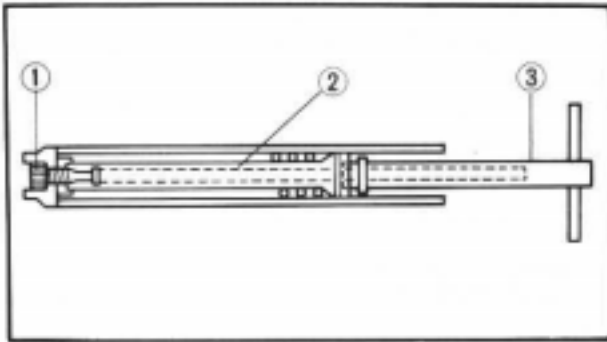

2. Remove:
 - Bolt (damper rod) (1)
 - Damper rod (2)

NOTE: _____
 Use a damper rod holder (3) to lock the damper rod.



Damper rod holder:
 90890-01425

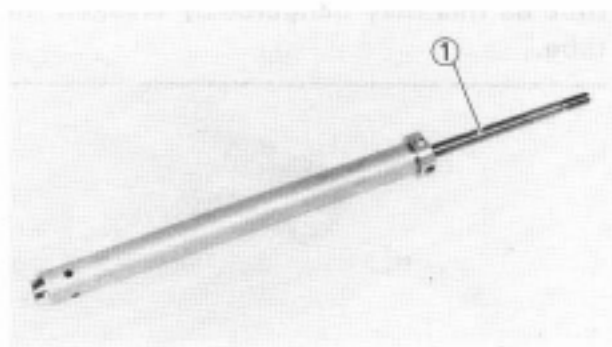

INSPECTION

Damper rod

1. Inspect:
 - Damper rod (1)
 Bend/Damage → Replace damper rod.

CAUTION: _____

The front fork with a built-in piston rod has a very sophisticated internal construction and is particularly sensitive to foreign material.

Use enough care not to allow any foreign material to come in when the oil is replaced or when the front fork is disassembled and reassembled.

5

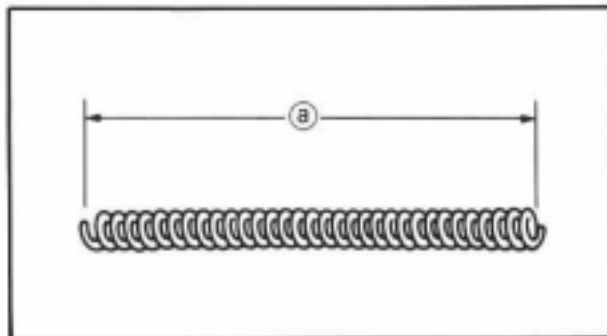

Fork spring

1. Measure:
 - Fork spring free length (a)
 Out of specification → Replace.



Fork spring free length:

Standard	Limit
195 mm (7.68 in)	193 mm (7.60 in)

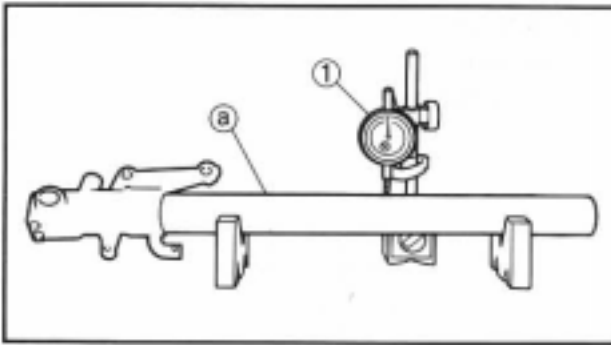

Inner tube

1. Inspect:

- Inner tube surface (a)
Score marks → Repair or replace.
Use #1,000 grit wet sandpaper.
Damaged oil lock piece → Replace.
- Inner tube bends
Out of specification → Replace.
Use dial gauge (1).



Inner tube bending limit:
0.2 mm (0.008 in)

NOTE:

The bending value is shown by one half of the dial gauge reading.

⚠ WARNING

Do not attempt to straighten a bent inner tube as this may dangerously weaken the tube.

5

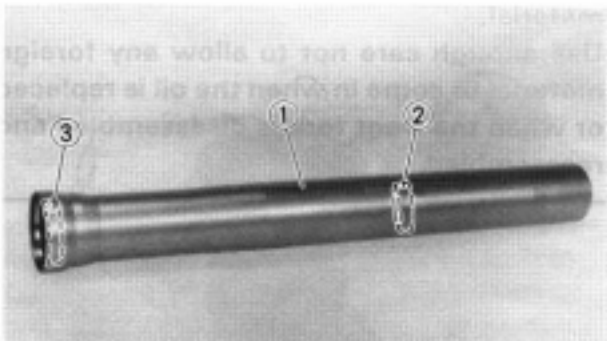

Outer tube

1. Inspect:

- Outer tube (1)
Damage → Replace.
- Piston metal (2)
- Slide metal (3)
Score marks/Wear → Replace the outer tube.



Cap bolt

1. Inspect:

- Cap bolt (1)
- O-ring (2)
Wear/Damage → Replace.

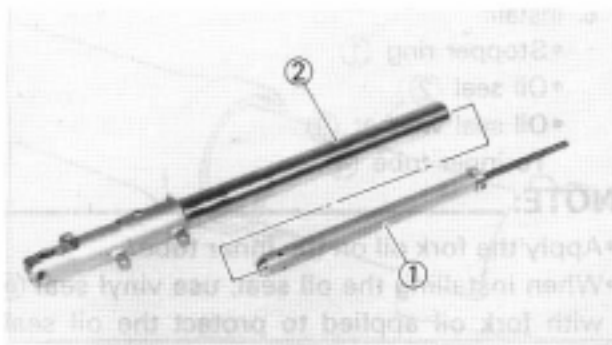

ASSEMBLY AND INSTALLATION

Front fork assembly

1. Wash the all parts in a clear solvent.
2. Install:
 - Damper rod ①
 - To inner tube ②.

CAUTION:

To install the damper rod assembly into the inner tube, hold the inner tube aslant. If the inner tube is held vertically, the rod assembly may fall into it, damaging the valve inside.

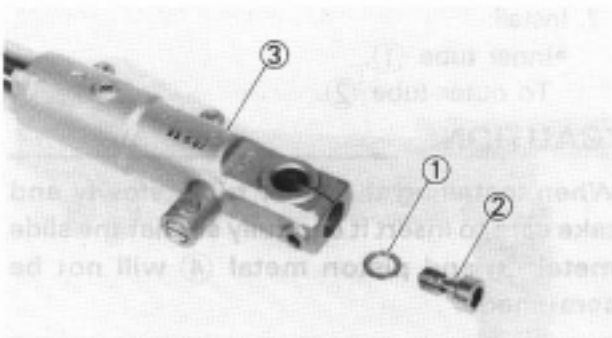

3. Install:
 - Copper washer ①
 - Bolt (damper rod) ②
 - To inner tube ③.

NOTE:

Always use a new copper washer.

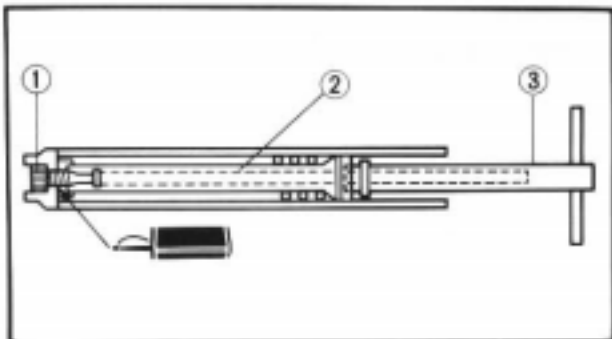

4. Tighten:
 - Bolt (damper rod) ①

NOTE:

Use a damper rod holder ③ to lock the damper rod ②.



Damper rod holder:
90890-01425



Bolt (damper rod):
40 Nm (4.0 m·kg, 29 ft·lb)
LOCTITE®

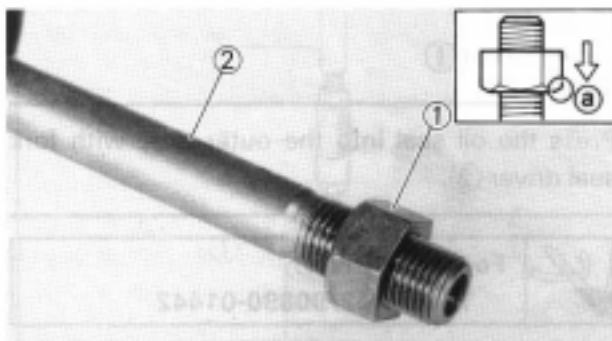

5. Install:
 - Locknut ①
 - To damper rod ②.

NOTE:

Install the locknut with its chamfered corner ① facing downward.

5

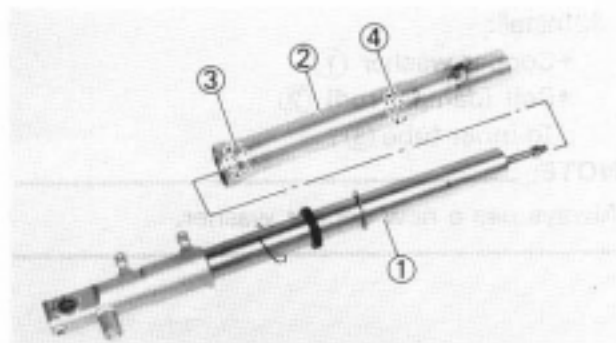
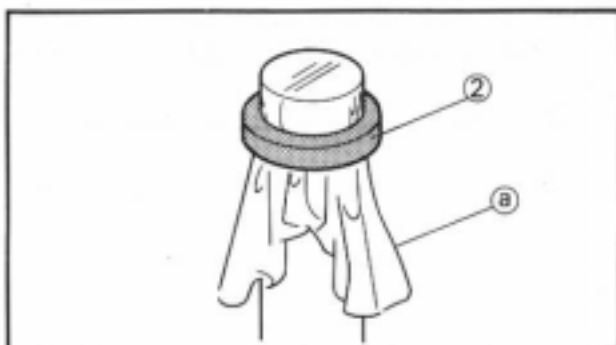
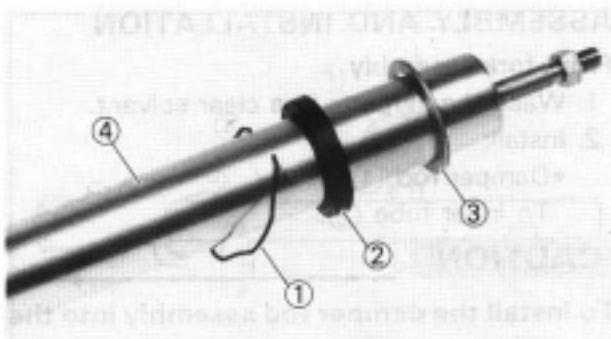

5

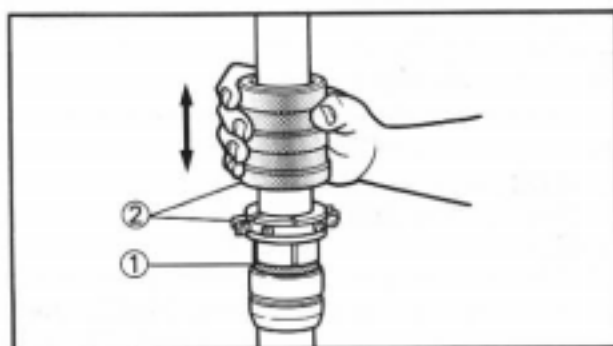

6. Install:

- Stopper ring ①
 - Oil seal ②
 - Oil seal washer ③
- To inner tube ④.

NOTE:

- Apply the fork oil on the inner tube.
- When installing the oil seal, use vinyl seat (a) with fork oil applied to protect the oil seal lip.
- Install the oil seal with its manufacture's marks or number facing the axle holder side.

CAUTION:

Always use a new oil seal.

7. Install:

- Inner tube ①.
- To outer tube ②.

CAUTION:

When installing the inner tube, slowly and take care to insert it carefully so that the slide metal ③ and piston metal ④ will not be scratched.

8. Install:

- Oil seal washer ①
- To outer tube slot.

9. Install:

- Oil seal ①

NOTE:

Press the oil seal into the outer tube with fork seal driver ②.



Fork seal driver:

YM-01442/90890-01442

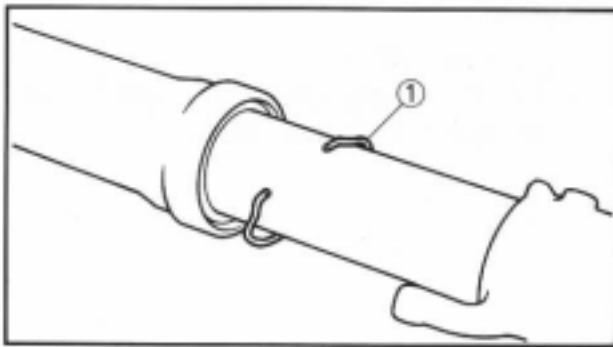

10. Install:

- Stopper ring ①

NOTE: _____

Fit the stopper ring correctly in the groove in the outer tube.

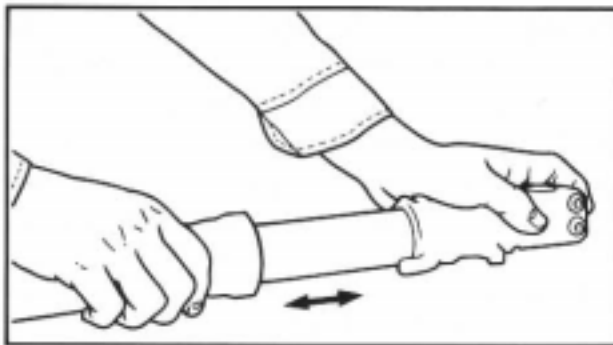

11. Check:

- Inner tube smooth movement
- Tightness/Binding/Rough spots → Repeat the steps 2 to 10.

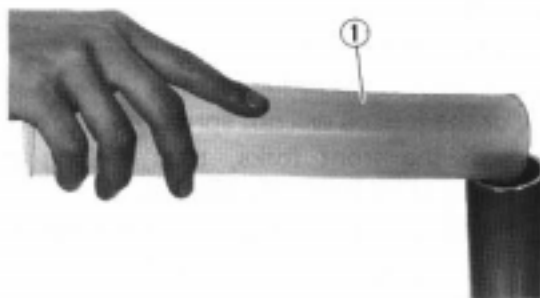

12. Compress the front fork fully.

13. Fill:

- Front fork oil
- Until outer tube top surface with recommended fork oil ①.



Recommended oil:
Suspension oil "01"

CAUTION: _____

- Be sure to use recommended fork oil. If other oils are used, they may have an excessively adverse effect on the front fork performance.
- Never allow foreign materials to enter the front fork.

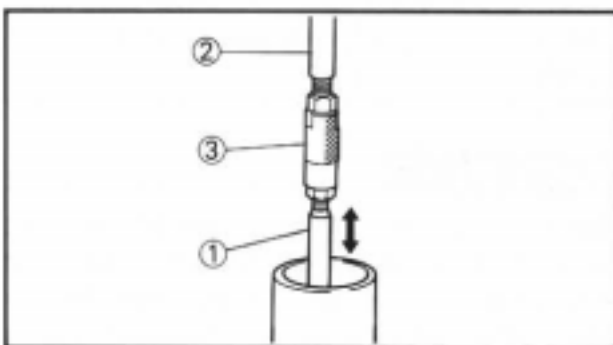

14. After filling, pump the damper rod ① slowly up and down more than 10 times to distribute the fork oil.

NOTE: _____

Use the rod puller ② and rod puller attachment ③ to pull up and down the damper rod.



Rod puller:
YM-01437/90890-01437
Rod puller attachment:
90890-01436

5

15. Fill:

- Front fork oil
Until outer tube top surface with recommended fork oil once more.

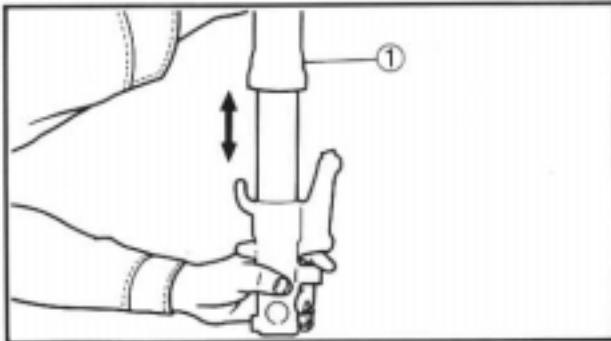

16. After filling, pump the outer tube ① slowly up and down (about 60 mm (2.4 in) stroke) to distribute the fork oil once more.

NOTE:

Be careful not to excessive full stroke. A stroke of 60 mm (2.4 in) or more will cause air to enter. In this case, repeat the steps 13 to 16.

17. Wait ten minutes until the air bubbles have been removed from the front fork, and the oil has dispense evenly in system before setting recommended oil level.

NOTE:

Fill with the fork oil up to the top end of the outer tube, or the fork oil will not spread over to every part of the front forks, thus making it impossible to obtain the correct level. Be sure to fill with the fork oil up to the top of the outer tube and bleed the front forks.

18. Measure:

- Oil level (left and right) ②
Out of specification → Adjust.

5

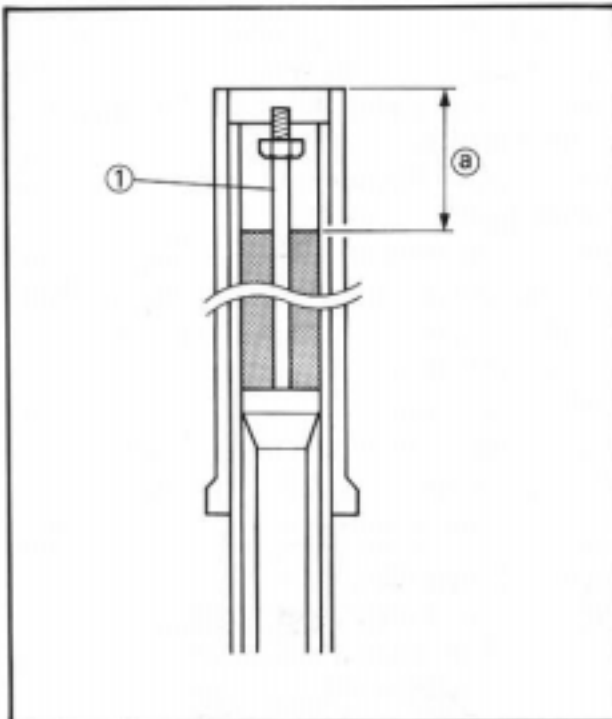

Fork oil level:	
Standard	110 mm (4.33 in)
Minimum	140 mm (5.51 in)
Maximum	80 mm (3.15 in)
From top of outer tube with inner tube and damper rod ① fully compressed without spring.	

⚠ WARNING

Never fail to make the oil level adjustment between the maximum and minimum level and always adjust each front fork to the same setting. Uneven adjustment can cause poor handling and loss of stability.

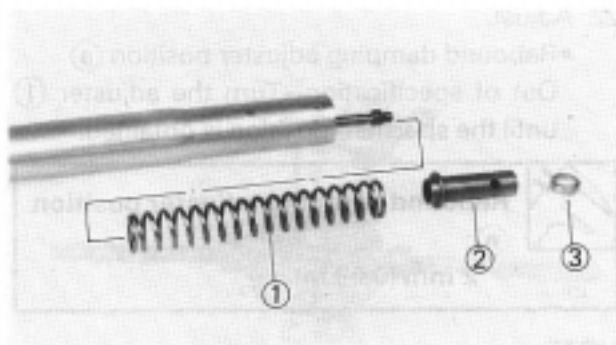

19. Install:

- Fork spring ①
- Spacer ②
- Spacer guide ③

NOTE: _____

Install the fork spring with its smaller dia. portion upward.

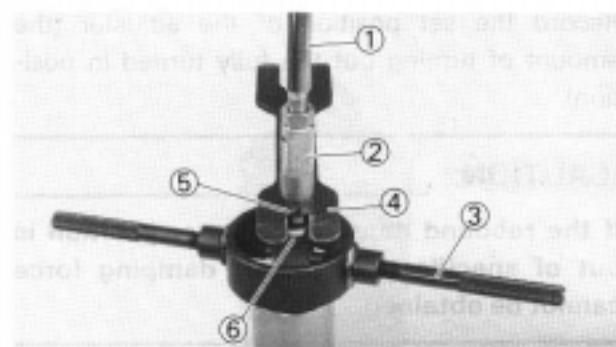

20. Attach:

- Rod puller ①
- Rod puller attachment ②
- Fork spring compressor ③
- Rod holder ④

NOTE: _____

- Pull up the damper rod with rod puller and rod puller attachment.
- While compressing the fork spring with fork spring compressor, set the rod holder between the locknut ⑤ and spacer guide ⑥.



Rod puller:

YM-01437/90890-01437

Rod puller attachment:

90890-01436

Fork spring compressor:

YM-01441/90890-01441

Rod holder:

YM-01434/90890-01434

5

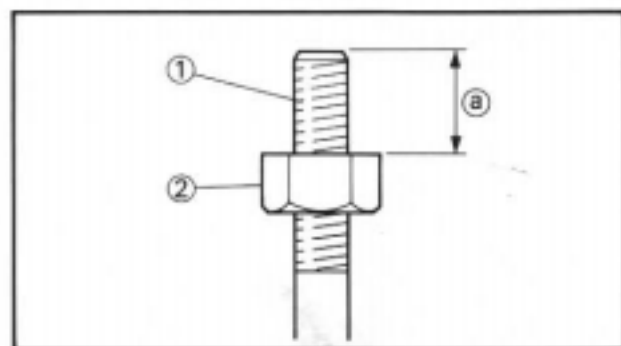

21. Adjust:

- Distance ①
- Out of specification → Turn the locknut ② until the specified distance is obtained.



Distance ①:

12 mm (0.47 in) or more

Between damper rod ① top and locknut ② top.

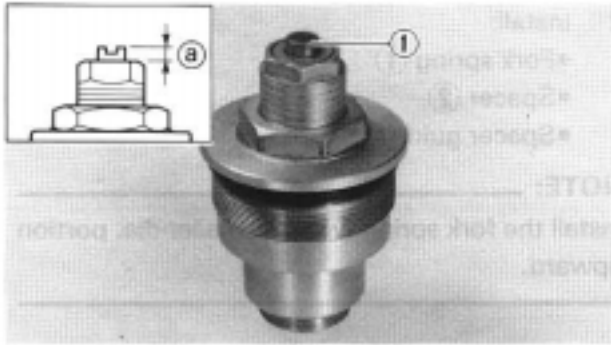

22. Adjust:

- Rebound damping adjuster position (a)
Out of specification—Turn the adjuster (1) until the specified position is obtained.

**Rebound damping adjuster position**

(a):
2 mm (0.08 in)

NOTE:

Record the set position of the adjuster (the amount of turning out the fully turned in position).

CAUTION:

If the rebound damping adjuster position is out of specification, proper damping force cannot be obtained.

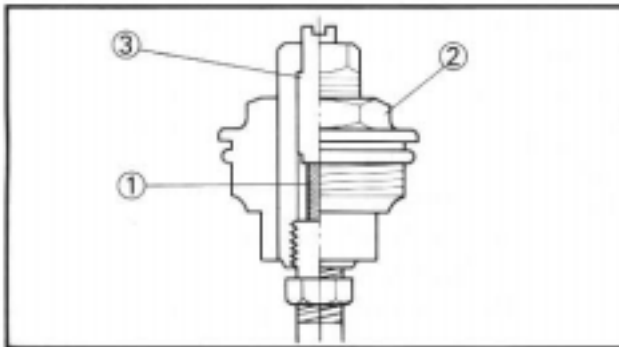

23. Install:

- Push rod (1)
- Cap bolt (2)

NOTE:

Turn in the cap bolt fully by hand until the rebound damping adjuster (3) hits the push rod tip.

5

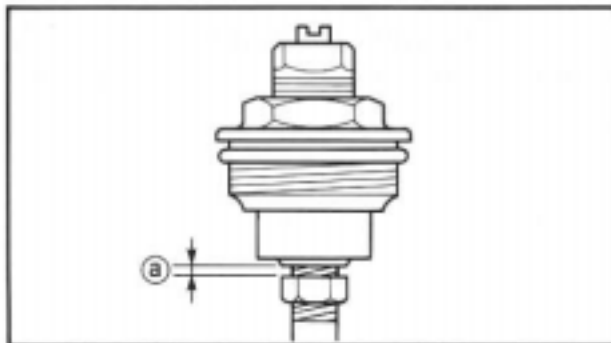

24. Check:

- Cap bolt clearance (a)
Out of specification—Repeat the steps 21 to 23.



Cap bolt clearance (a):
Zero–2 mm (Zero–0.08 in)

CAUTION:

If the cap bolt is installed out of specification, proper damping force cannot be obtained.

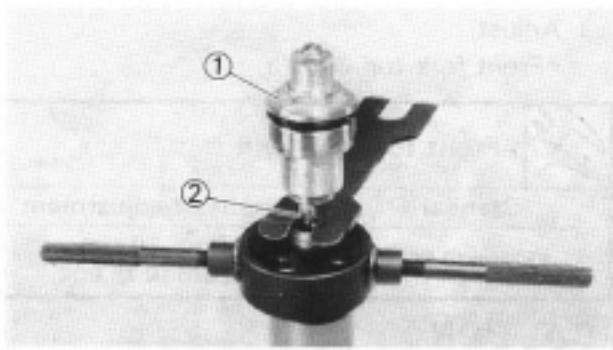

25. Install:

- Cap bolt ①

NOTE: _____

Hold the locknut ② and tighten the cap bolt with specified torque.



Cap bolt:

15 Nm (1.5 m•kg, 11 ft•lb)



26. Install:

- Cap bolt ①
- To outer tube.

NOTE: _____

Temporarily tighten the cap bolt.

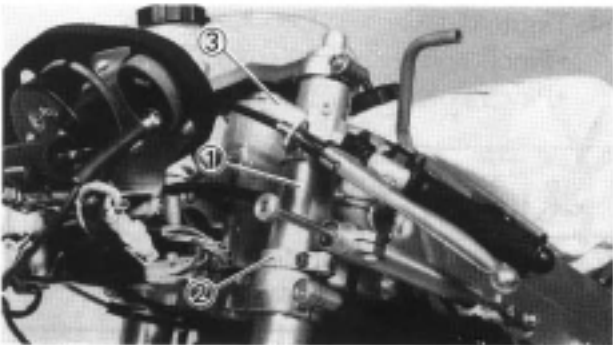

Installation

1. Install:

- Front fork ①
- Steering damper stay ② (left side only)
- Handlebar ③

NOTE: _____

- Temporarily tighten the pinch bolt (under bracket).
- Do not tighten the pinch bolts (handle crown, steering damper stay and handle bracket) yet.

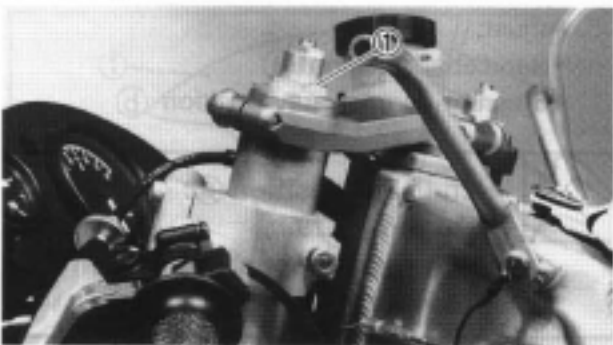

2. Tighten:

- Cap bolt ①



Cap bolt:

23 Nm (2.3 m•kg, 17 ft•lb)

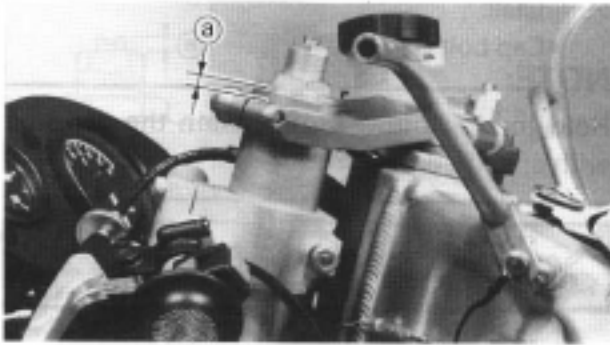

3. Adjust:

- Front fork top end (a)



Front fork top end (a):

Standard	Extent of adjustment
15 mm (0.59 in)	Zero~20 mm (Zero~0.79 in)

CAUTION:

Never attempt to install the front fork beyond the maximum or minimum setting.

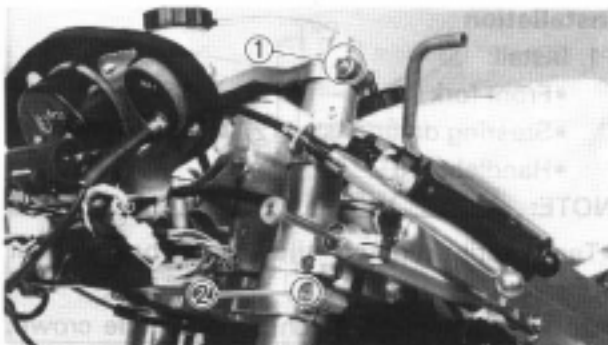

4. Tighten:

- Pinch bolt (handle crown) (1)
- Pinch bolt (under bracket) (2)



Pinch bolt (handle crown):

15 Nm (1.5 m·kg, 11 ft·lb)

Pinch bolt (under bracket):

20 Nm (2.0 m·kg, 1.4 ft·lb)

CAUTION:

Tighten the pinch bolts to specified torque. If torqued too much, it may cause the front fork to malfunction.

5



5. Adjust:

- Handlebar position (a)
- Steering damper stay position (b)



Handlebar position (a):

20 mm (0.79 in)

Steering damper stay position (b):

Zero mm (Zero in)

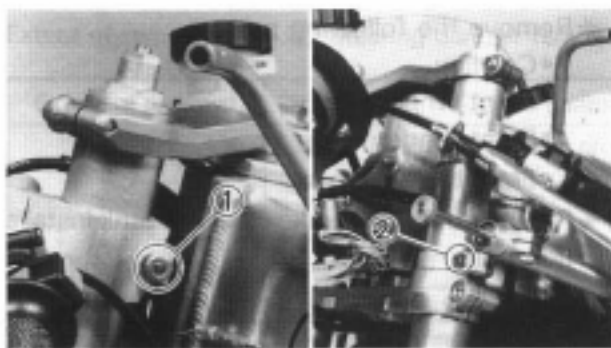

6. Tighten:

- Pinch bolt (handle bracket) ①
- Pinch bolt (steering damper stay) ②



Pinch bolt (handle bracket):

15 Nm (1.5 m•kg, 11 ft•lb)

Pinch bolt (steering damper stay):

7 Nm (0.7 m•kg, 5.1 ft•lb)

CAUTION:

Tighten the pinch bolts to specified torque. If torqued too much, it may cause the front fork to malfunction.

NOTE:

Adjust the installation angle of the steering damper stay so that the dimension ③ is between 5 mm (0.20 in) and 10 mm (0.39 in) when the handlebar is turned fully to the left.

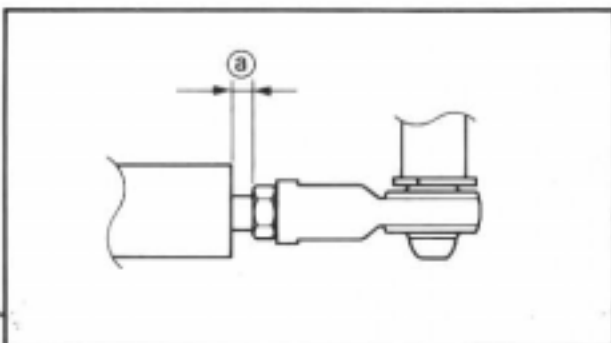

7. Check:

- Steering smooth action
- Turn the handlebar to make sure no parts are being contacted with others.
Contact → Repair.

8. Adjust:

- Rebound damping force

NOTE:

Turn out the damping adjuster ① to the originally set position.

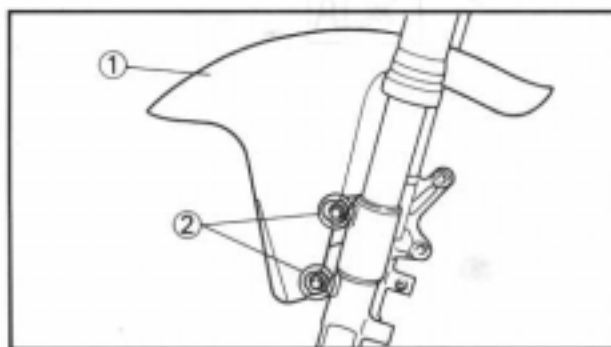

9. Install:

- Front fender ①
- Bolt (front fender) ②



Bolt (front fender):

8 Nm (0.8 m•kg, 5.8 ft•lb)

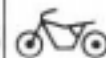

STEERING

PREPARATION FOR REMOVAL

* Hold the machine by placing the suitable stand.

⚠ WARNING

Support the machine securely so there is no danger of it falling over.

* Remove the following parts:

- Cowling
- Front wheel
- Front fender
- Front brake caliper

* Remove the front brake reservoir tank installation bolt.

A	15 Nm (1.5 m • kg, 11 ft • lb)
B	20 Nm (2.0 m • kg, 14 ft • lb)
C	40 Nm (4.0 m • kg, 29 ft • lb)
D	18 Nm (1.8 m • kg, 13 ft • lb)
E	5 Nm (0.5 m • kg, 3.6 ft • lb)
F	7 Nm (0.7 m • kg, 5.1 ft • lb)
G	TIGHTENING STEPS:
	<ul style="list-style-type: none"> • Tighten ring nut. 46 Nm (4.6 m • kg, 33 ft • lb) • Loosen it one turn. • Retighten it. 1 Nm (0.1 m • kg, 0.7 ft • lb)

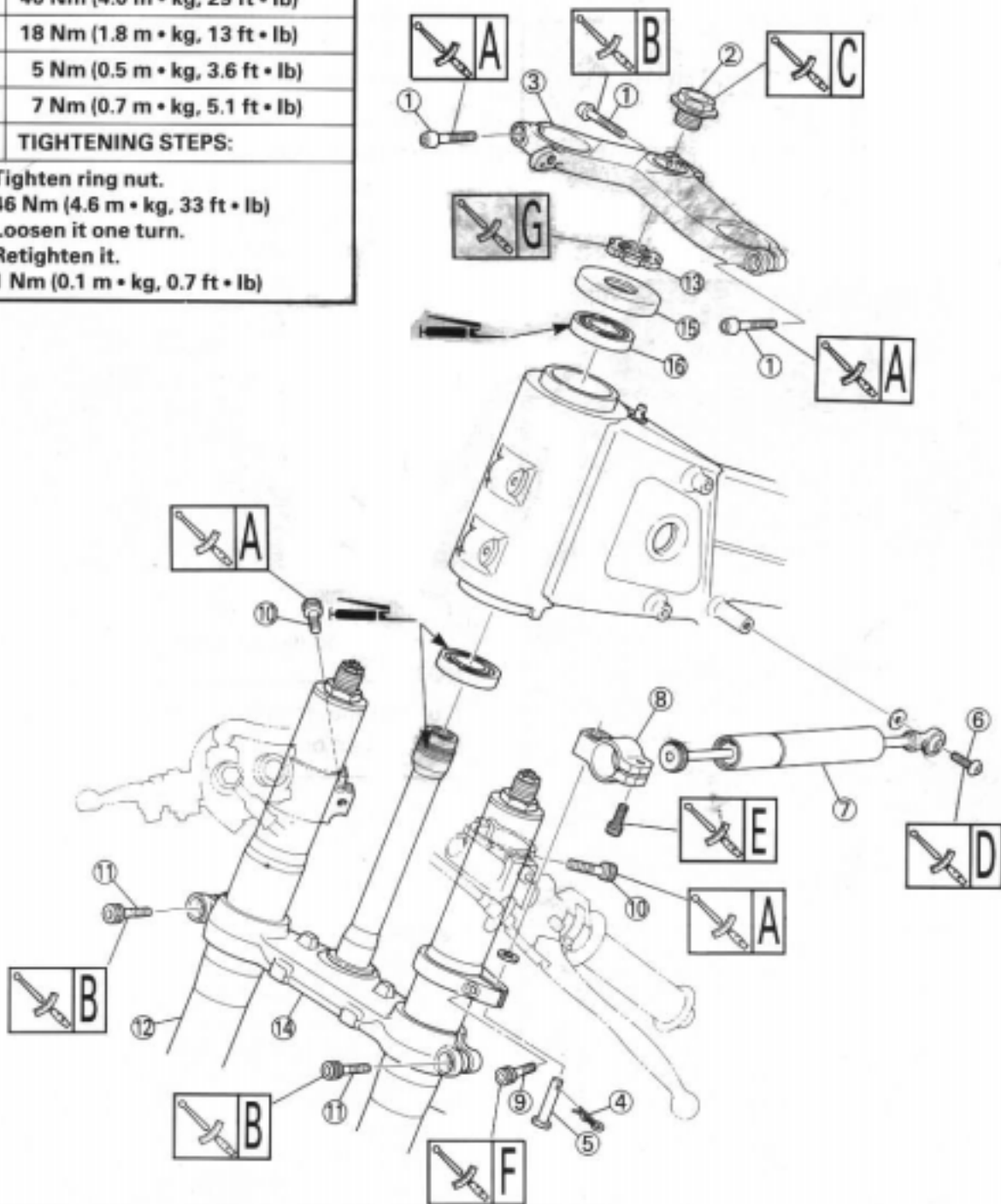

5



Extent of removal: ① Steering damper removal ② Under bracket removal

Extent of removal	Order	Part name	Q'ty	Remarks
① ↓ ② ↓	1	Pinch bolt (handle crown)	3	Only loosening.
	2	Steering shaft bolt	1	
	3	Handle crown	1	
	4	Clip	1	
	5	Pin	1	
① ↓	6	Bolt (steering damper)	1	
	7	Steering damper	1	
	8	Steering damper bracket	1	
	9	Pinch bolt (steering damper stay)	1	
	10	Pinch bolt (handle bracket)	2	
② ↓	11	Pinch bolt (under bracket)	2	Only loosening.
	12	Front fork	2	Refer to "FRONT FORK" section.
	13	Ring nut	1	Use special tool. Refer to "REMOVAL POINTS".
	14	Under bracket	1	
	15	Ball race cover	1	
	16	Bearing	1	



REMOVAL POINTS

Ring nut

- Remove:
 - Ring nut ①
 - Use the ring nut wrench ②.



Ring nut wrench:
YU-33975/90890-01403

⚠ WARNING

Support the steering shaft so that it may not fall down.

5



INSPECTION

Bearing

- Wash the bearings in solvent.
- Inspect:
 - Bearing (upper and lower) ①
 - Pitting/Damage → Replace races and bearing.
 Install the bearing in the races. Spin the bearings by hand. If the bearings hang up or are not smooth in their operation in the races, replace bearings and races.

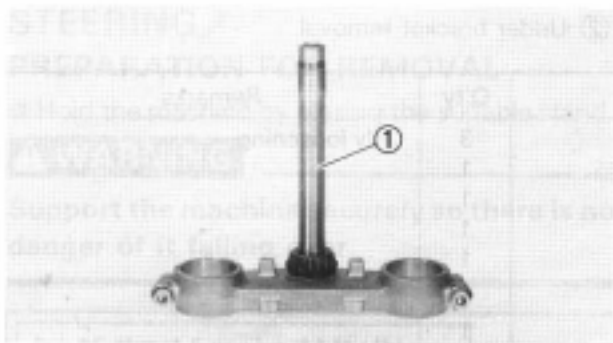

Steering shaft

1. Inspect:

- Steering shaft ①
Bend/Damage → Replace.

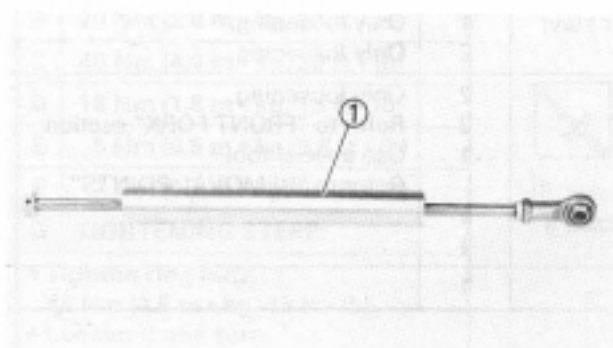

Steering damper

1. Inspect:

- Steering damper ①
Bend/Damage → Replace.

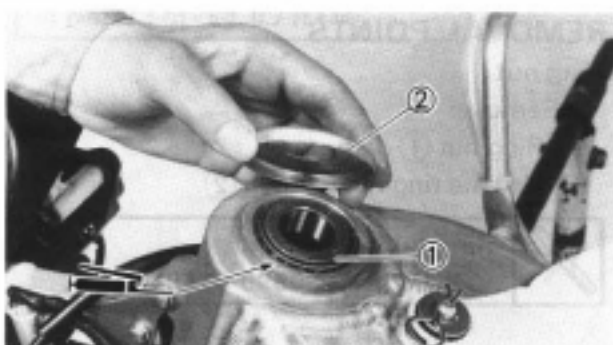

ASSEMBLY AND INSTALLATION

Under bracket

1. Install:

- Bearing ①
- Ball race cover ②

NOTE:

Apply the lithium soap base grease on the bearing.

2. Install:

- Under bracket ①

NOTE:

Apply the lithium soap base grease on the bearing.

3. Install:

- Ring nut ①
Use the ring nut wrench ②.

Ring nut tightening steps:

- Apply the lithium soap base grease on the steering shaft thread.
- Tighten the ring nut using the ring nut wrench ②.

5

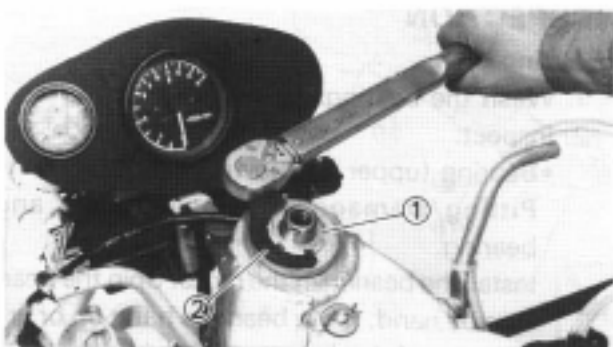
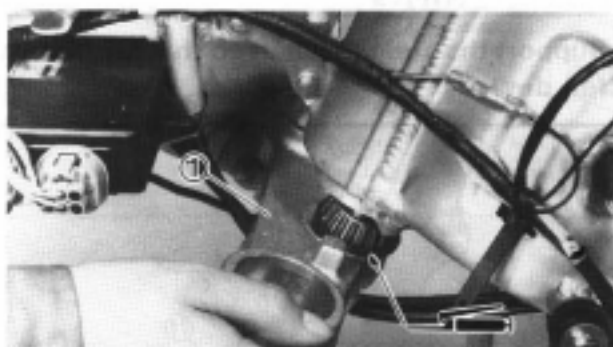

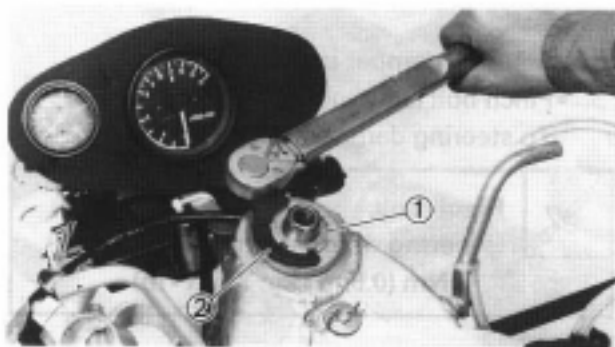
**NOTE:**

Set the torque wrench to the ring nut wrench so that they form a right angle.



Ring nut wrench:

YM-33975/90890-01403



Ring nut (initial tightening):

46 Nm (4.6 m·kg, 33 ft·lb)

- Loosen the ring nut one turn and retighten it to specification.

⚠ WARNING

Avoid over-tightening.



Ring nut (final tightening):

1 Nm (0.1 m·kg, 0.7 ft·lb)

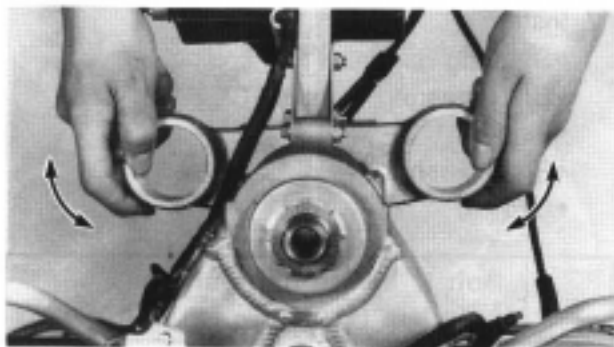

4. Check the steering shaft by turning it lock to lock. If there is any binding, remove the steering shaft assembly and inspect the steering bearings.

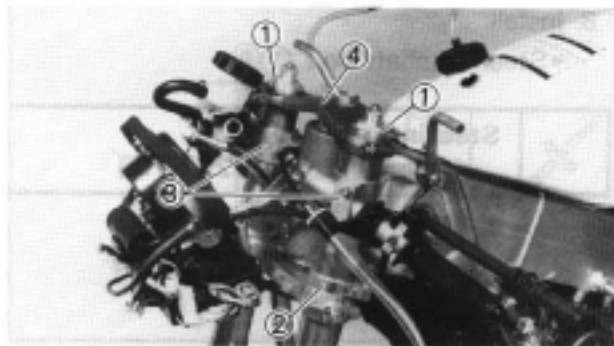

5. Install:

- Front fork ①
- Steering damper stay ② (left side only)
- Handlebar ③
- Handle crown ④

NOTE:

Temporarily tighten the pinch bolts.

5

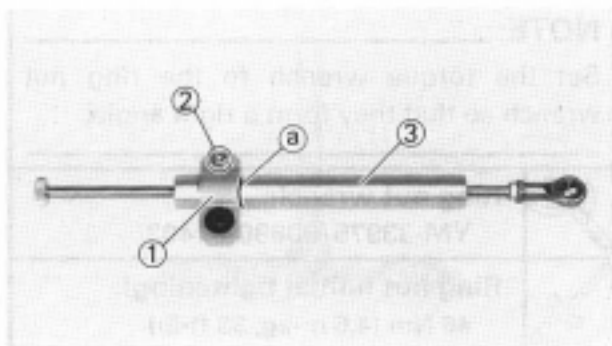

6. Install:

- Steering damper bracket ①
- Pinch bolt (steering damper bracket) ②
- To steering damper ③.



Pinch bolt
(steering damper bracket):
5 Nm (0.5 m•kg, 3.6 ft•lb)

NOTE:

When installing the steering damper bracket, align the edge of it with the groove ③ on the steering damper.

CAUTION:

Tighten the pinch bolt to specified torque. If torque too much, it may cause the steering damper to malfunction.

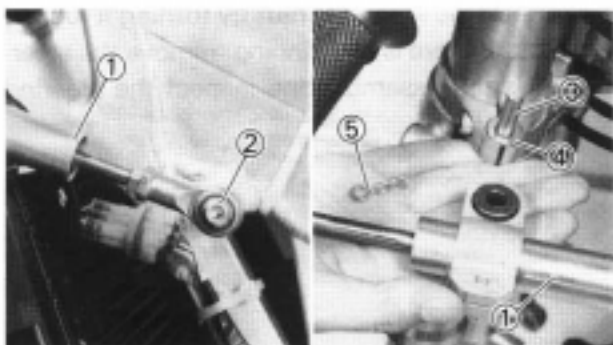

7. Install:

- Steering damper ①
- Bolt (steering damper) ②
- Pin ③
- Plain washer ④
- Clip ⑤



Bolt (steering damper):
18 Nm (1.8 m•kg, 13 ft•lb)

5

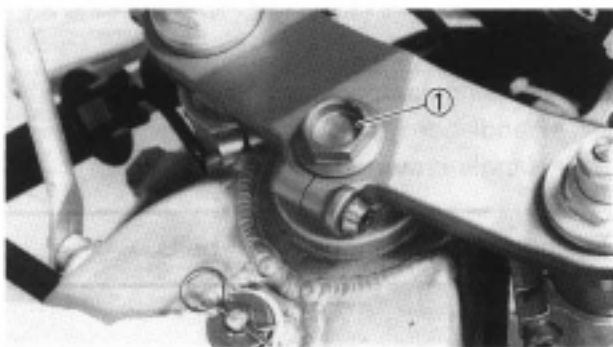

8. Install:

- Steering shaft bolt ①



Steering shaft bolt:
40 Nm (4.0 m•kg, 29 ft•lb)



9. Check:

- Steering smooth action
Turn the handlebar lock to lock.
Unsmooth action → Adjust the steering ring nut.



10. Tighten:
- Pinch bolt (steering shaft) ①

	Pinch bolt (steering shaft): 20 Nm (2.0 m·kg, 14 ft·lb)
--	---

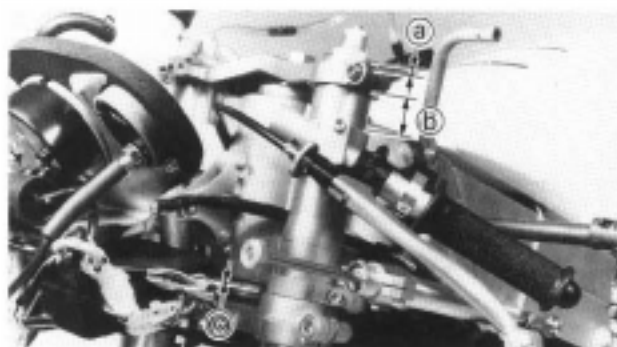

11. Adjust:
- Front fork top end ①
 - Handlebar position ②
 - Steering damper stay position ③

	Front fork top end ①: 15mm (0.59 in) Handlebar position ②: 20 mm (0.79 in) Steering damper stay position ③: Zero mm (Zero in)
--	---

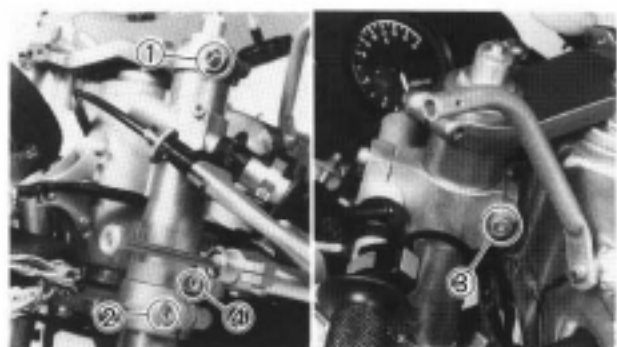

12. Tighten:
- Pinch bolt (handle crown) ①
 - Pinch bolt (under bracket) ②
 - Pinch bolt (handle bracket) ③
 - Pinch bolt (steering damper stay) ④

	Pinch bolt (handle crown): 15 Nm (1.5 m·kg, 11 ft·lb) Pinch bolt (under bracket): 20 Nm (2.0 m·kg, 14 ft·lb) Pinch bolt (handle bracket): 15 Nm (1.5 m·kg, 11 ft·lb) Pinch bolt (steering damper stay): 7 Nm (0.7 m·kg, 5.1 ft·lb)
--	---

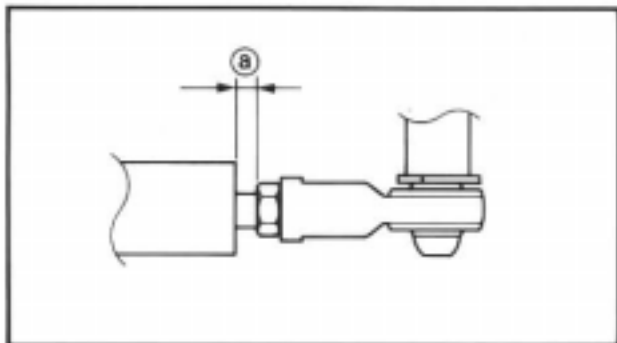

5

CAUTION: _____

Tighten the pinch bolts to specific torque. If torqued too much, it may cause the front fork to malfunction.

NOTE: _____

Adjust the installation angle of the steering damper stay so that the dimension ① is between 5 mm (0.20 in) and 10 mm (0.39 in) when the handlebar is turned fully to the left.



SWINGARM PREPARATION FOR REMOVAL

* Hold the machine by placing the suitable stand.

⚠ WARNING

Support the machine securely so there is no danger of it falling over.

* Remove the following parts:

- Lower cowl
- Exhaust pipe
- Rear wheel
- Brake hose holder

SWINGARM FREE PLAY LIMIT
END: 1.0 mm (0.04 in)
SIDE CLEARANCE:
 0.05~0.35 mm (0.002~0.014 in)

A	2 Nm (0.2 m • kg, 1.4 ft • lb)
B	63 Nm (6.3 m • kg, 45 ft • lb)
C	34 Nm (3.4 m • kg, 24 ft • lb)

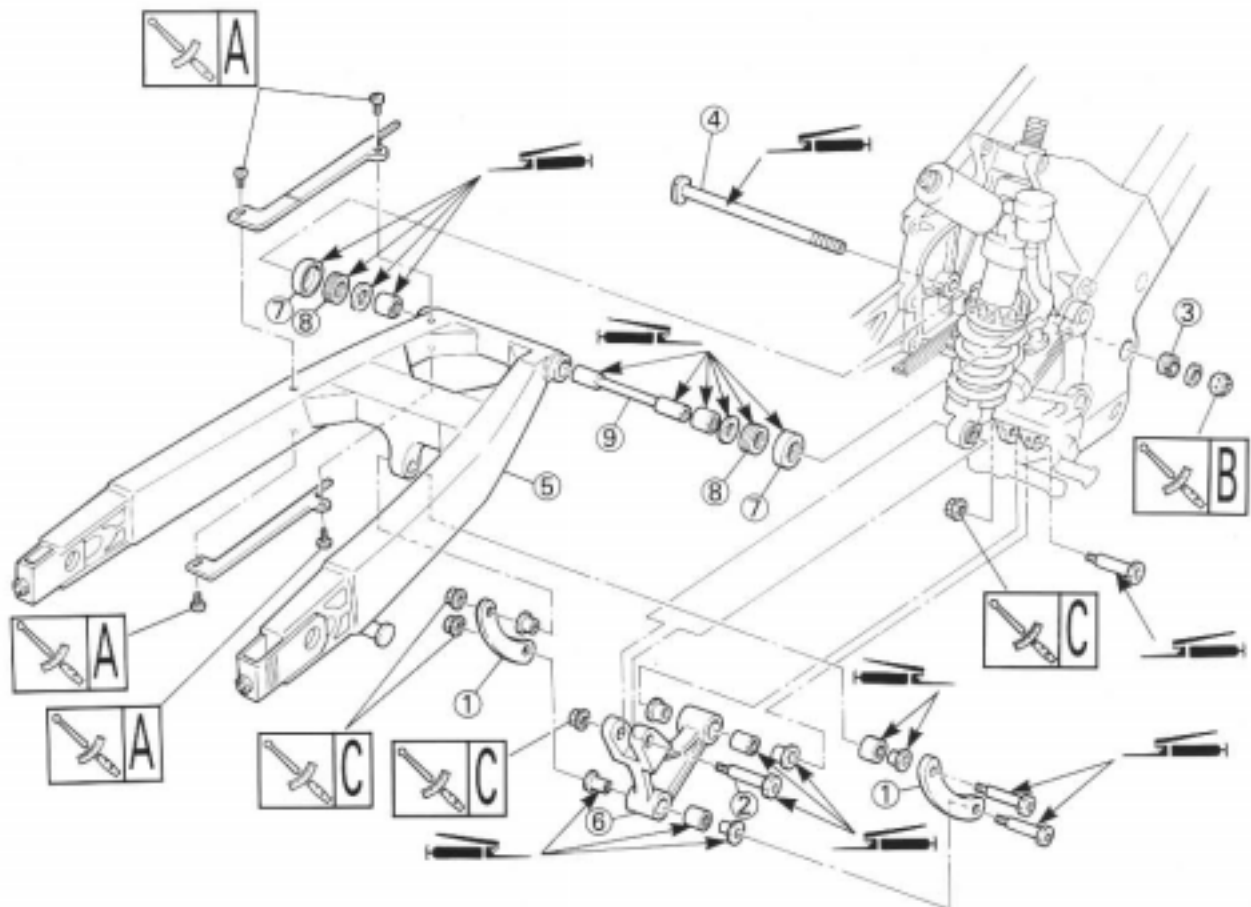



NOTE ON REMOVAL AND REASSEMBLY

•For reassembly, the removed parts should be cleaned with the solvent, and apply the grease onto the sliding surface.

Extent of removal: ① Swingarm removal ② Swingarm disassembly

Extent of removal	Order	Part name	Q'ty	Remarks
①	1	Connecting rod	2	Use special tool. Refer to "REMOVAL POINTS".
	2	Bolt (rear shock absorber)	1	
	3	Pivot shaft adjust bolt	1	
	4	Pivot shaft	1	
	5	Swingarm	1	
②	6	Relay arm	1	
	7	Cover	2	
	8	Thrust bearing	2	
	9	Bush	1	

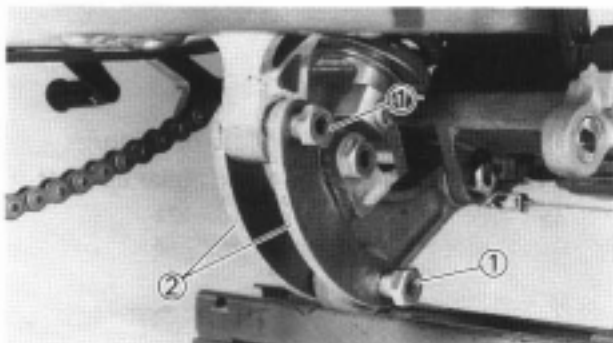

REMOVAL POINTS

Swingarm

- Remove:
 - Bolt (connecting rod) ①
 - Connecting rod ②

NOTE: _____
Remove the bolt while holding the swingarm.

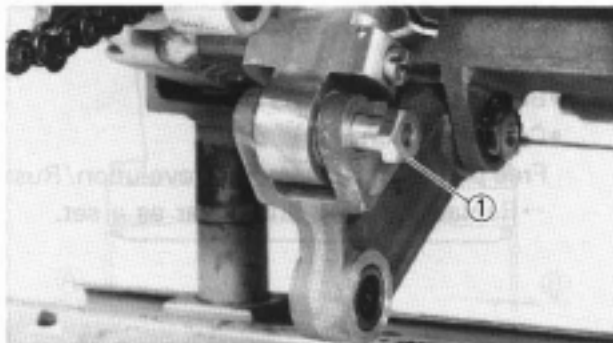

- Remove:
 - Bolt (rear shock absorber—relay arm) ①

5

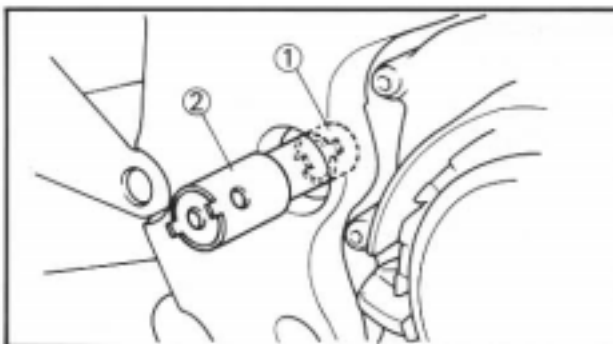

- Loosen:
 - Pivot shaft adjust bolt ①

NOTE: _____
Loosen the pivot shaft adjust bolt using a pivot shaft wrench ②.

	Pivot shaft wrench: YM-01455/90890-01455
--	--

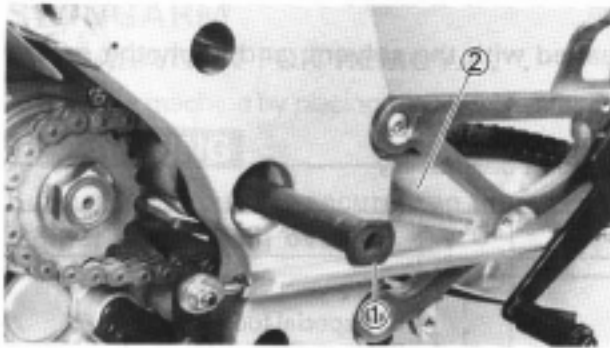

4. Remove:

- Pivot shaft ①
- Swingarm ②

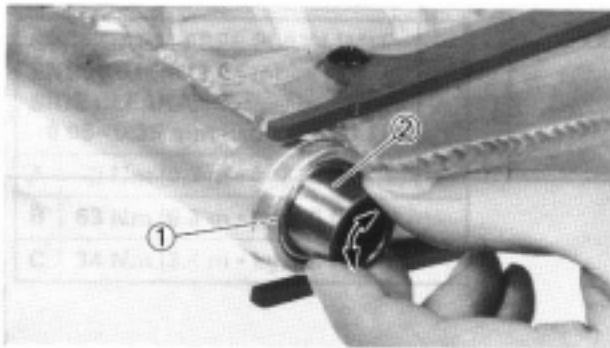
**INSPECTION**

Wash the bearings, bushes, collars, and thrust covers in a solvent.

Swingarm

1. Inspect:

- Bearing (swingarm) ①
 - Bush (swingarm) ②
- Free play exists/Unsmooth revolution/
Rust→Replace bearing and bush as a set.

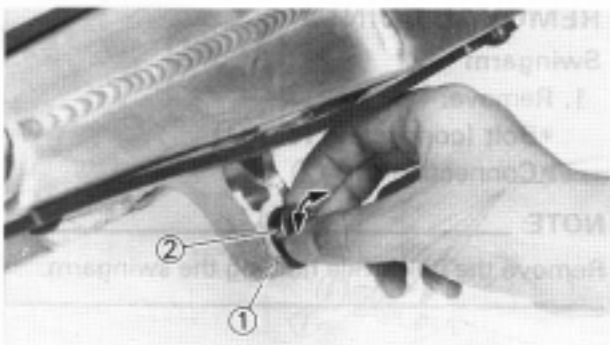

2. Inspect:

- Bearing (swingarm) ①
 - Collar (swingarm) ②
- Free play exists/Unsmooth rotation/
Rust→Replace bearing and collar as a set.

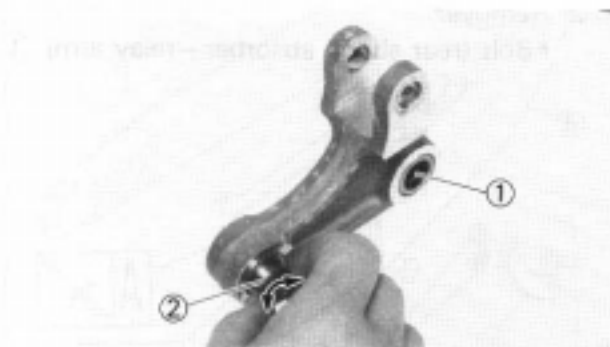
5**Relay arm**

1. Inspect:

- Bearing (relay arm) ①
 - Collar (relay arm) ②
- Free play exists/Unsmooth revolution/Rust
→Replace bearing and collar as a set.

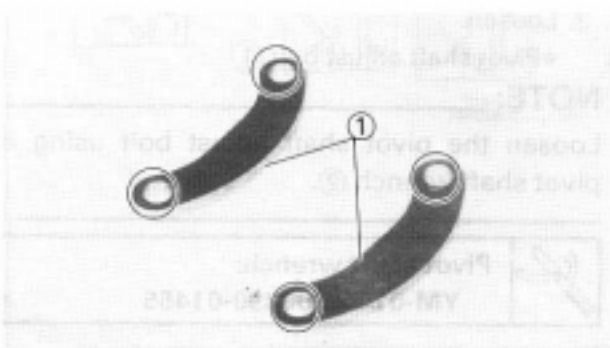
**Connecting rod**

1. Inspect:

- Connecting rod ①
- Wear/Damage→Replace.

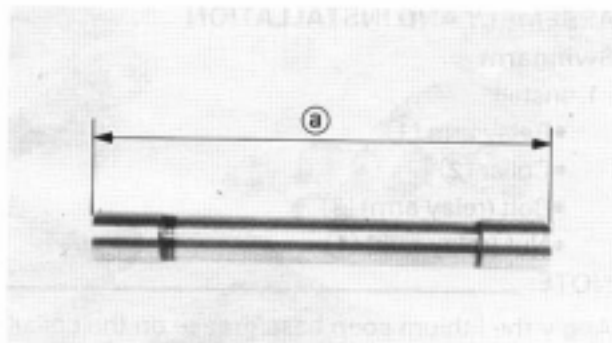

Swingarm side clearance

1. Measure:
 - Bush length (a)

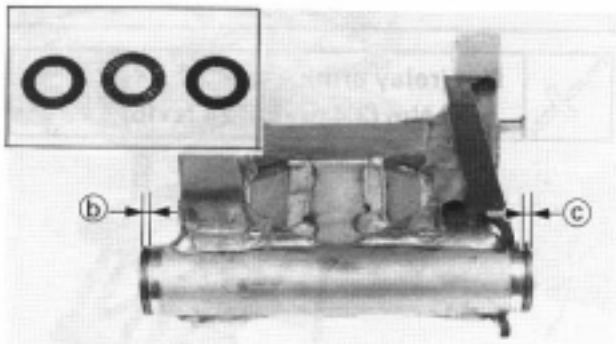

2. Measure:
 - Thrust bearing (right) thickness (b)
 - Thrust bearing (left) thickness (c)

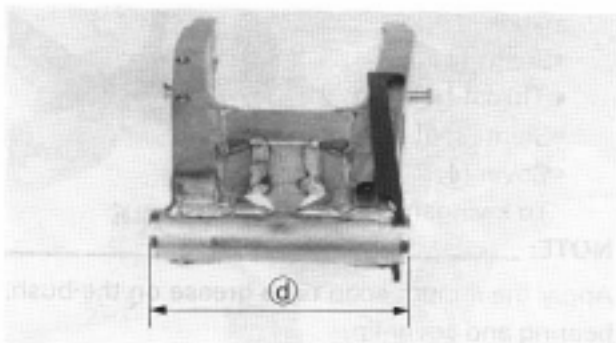

3. Measure:
 - Swingarm head pipe length (d)

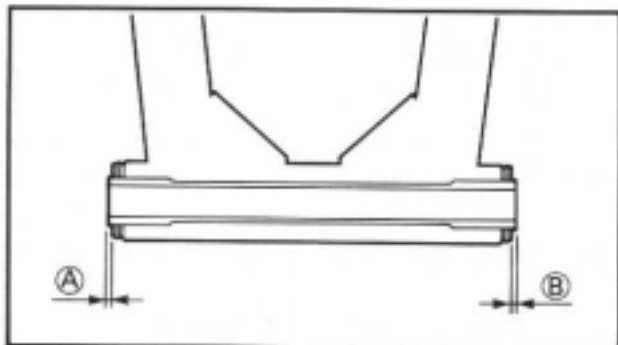

4. Calculate:
 - Swingarm side clearance "(A + B)"
 - Out of specification → Adjust side clearance using shim.
 - By using formula given below.

$$"A + B" = a - (b + c + d)$$

Side clearance "(A + B)":
0.05–0.35 mm (0.002–0.014 in)

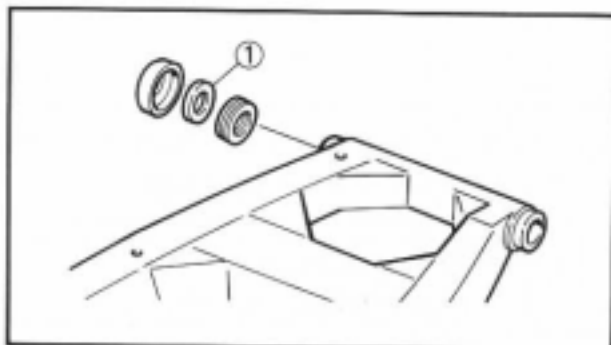

If the thrust clearance is out of specification, adjust it to specification by installing the adjust shim (1) at position, (A) and (B).

- NOTE:**
- The adjust shim is available only in the 0.3 mm (0.012 in)-thick type.
 - When only one shim is required, install it on the left side, and when two shims are necessary, install them on both right and left sides.

5

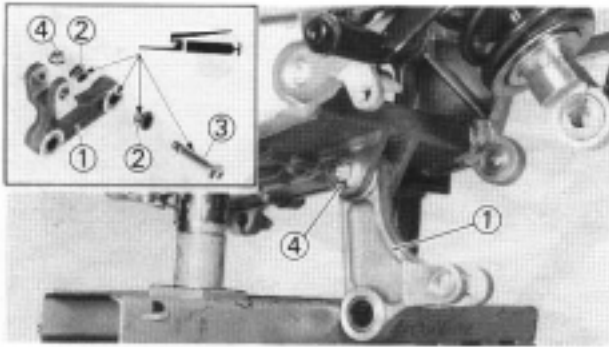

ASSEMBLY AND INSTALLATION

Swingarm

1. Install:

- Relay arm ①
- Collar ②
- Bolt (relay arm) ③
- Nut (relay arm) ④

NOTE:

Apply the lithium soap base grease on the collar, bearing and bolt.



Nut (relay arm):

34 Nm (3.4 m•kg, 24 ft•lb)

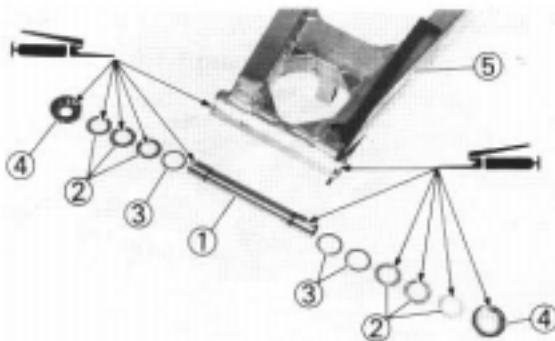

2. Install:

- Bush ①
 - Thrust bearing ②
 - Shim ③ (if necessary)
 - Cover ④
- To swingarm ⑤.

NOTE:

Apply the lithium soap base grease on the bush, bearing and cover lip.

5

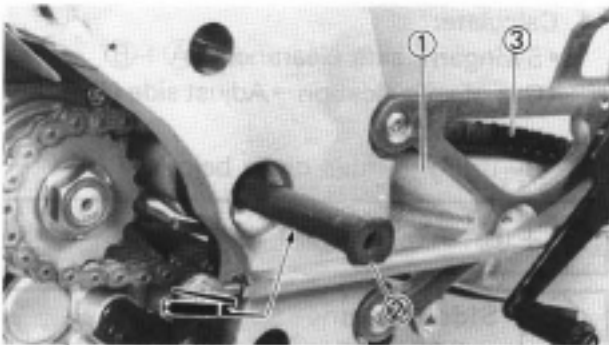

3. Install:

- Swingarm ①
- Pivot shaft ②

NOTE:

- Install the swingarm together with the drive chain ③ to the chassis.
- Apply the lithium soap base grease on the pivot shaft.
- Insert the pivot shaft from left side.

4. Tighten:

- Pivot shaft adjust bolt ①

NOTE:

Use the pivot shaft wrench ② to tighten the pivot shaft adjust bolt to finger tightness.



Pivot shaft wrench:

YM-01455/90890-01455

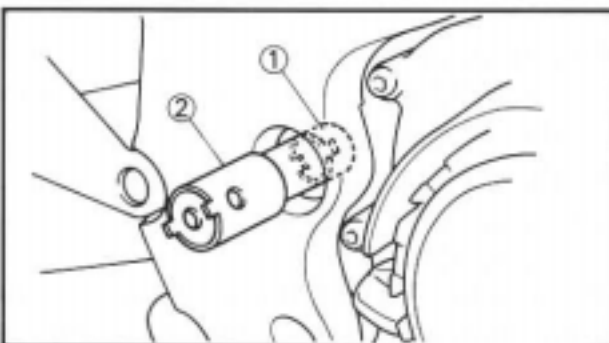

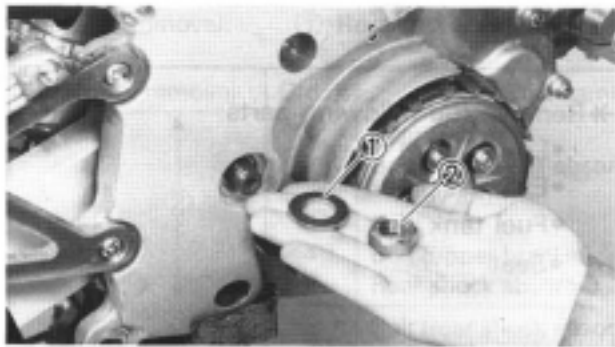
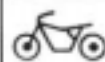

5. Install:

- Plain washer ①
- Nut (pivot shaft) ②



Nut (pivot shaft):
63 Nm (6.3 m•kg, 45 ft•lb)

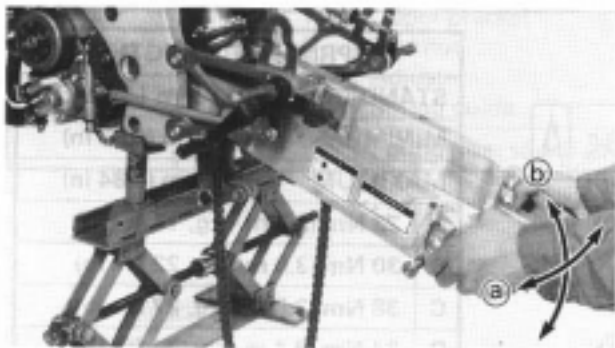

6. Check:

- Swingarm side play (a)
Free play exists → Check side clearance.
- Swingarm up and down movement (b)
Unsmooth movement/Binding/Rough spots
→ Grease or replace bearings, solid bushes and collars.



7. Install:

- Bolt (rear shock absorber—relay arm) ①
- Nut (rear shock absorber—relay arm) ②

NOTE:

Apply the lithium soap base grease on the bolt.



**Nut (rear shock absorber—
relay arm):**
34 Nm (3.4 m•kg, 24 ft•lb)

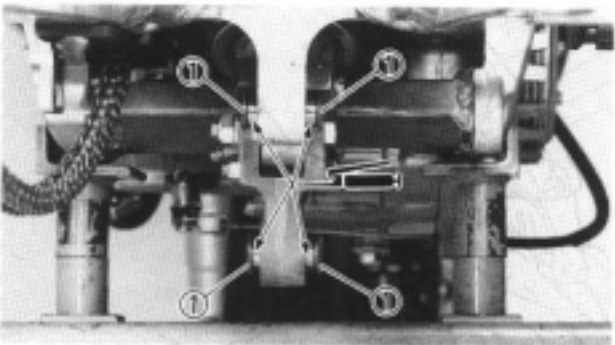

8. Install:

- Collar (swingarm) ①

NOTE:

Apply the lithium soap base grease on the bearing and collar.

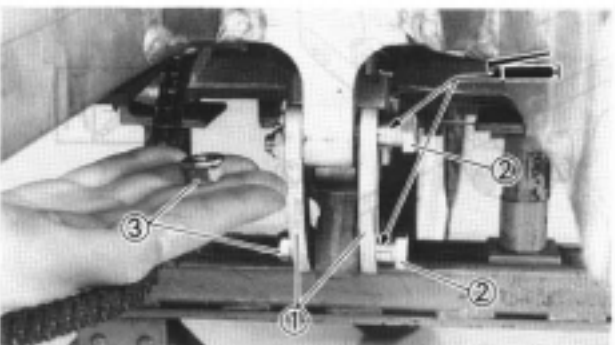

9. Install:

- Connecting rod ①
- Bolt (connecting rod) ②
- Nut (connecting rod) ③

NOTE:

Apply the lithium soap base grease on the bolt.



Nut (connecting rod):
34 Nm (3.4 m•kg, 24 ft•lb)

5

**REAR SHOCK ABSORBER
PREPARATION FOR REMOVAL**

*Hold the machine by placing the suitable stand.

⚠ WARNING

Securely support the machine so there is no danger of it falling over.

* Remove the following parts:

- Lower cowl
- Exhaust pipe
- Fuel tank
- Seat

5

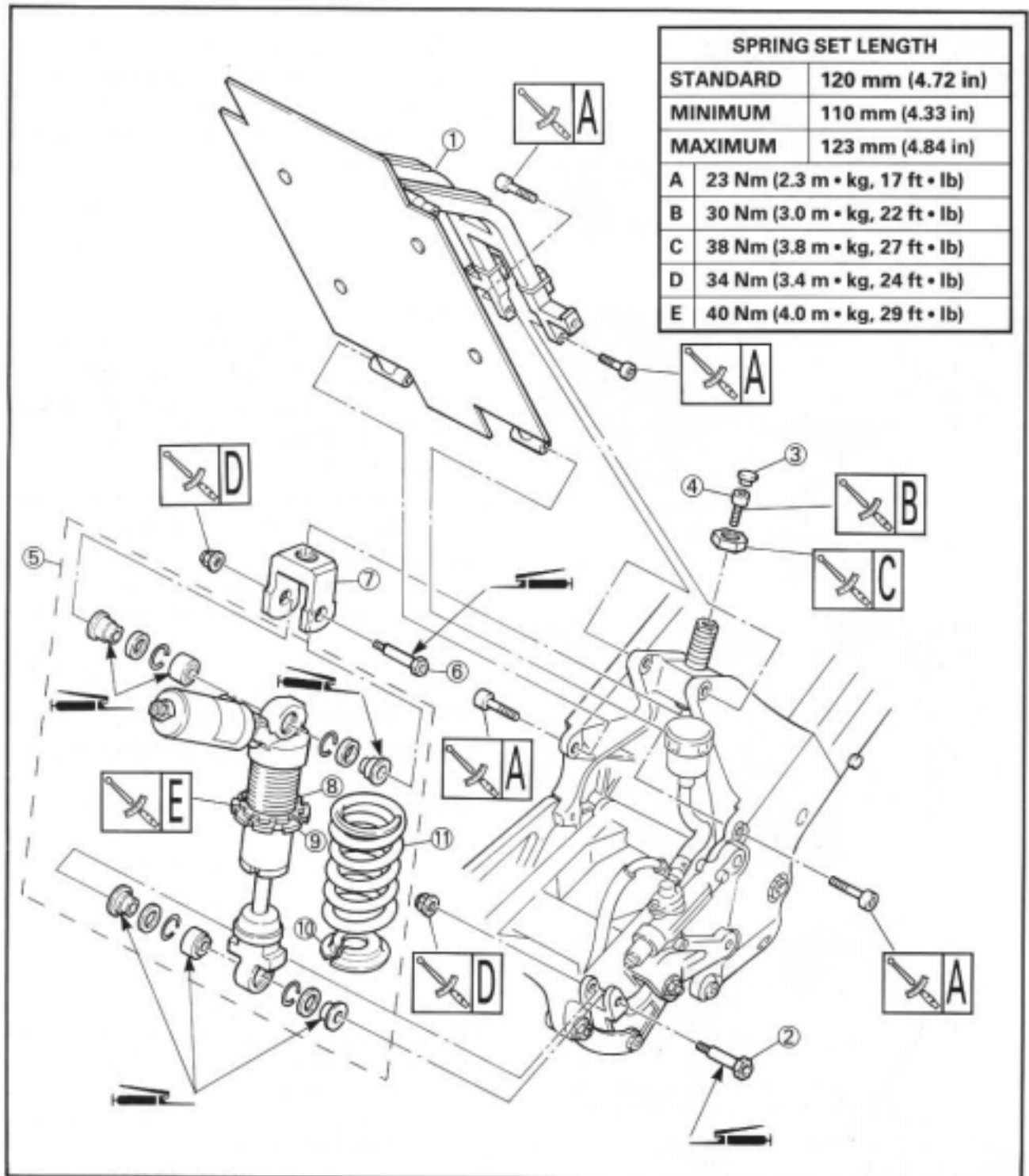



Extent of removal: ① Rear shock absorber removal ② Spring (rear shock absorber) removal

Extent of removal	Order	Part name	Q'ty	Remarks
	1	Rear frame	1	Refer to "REMOVAL POINTS".
	2	Bolt (rear shock absorber —relay arm)	1	
	3	Cap	1	
	4	Bolt (upper bracket)	1	
	5	Rear shock absorber	1	
	6	Bolt (rear shock absorber —upper bracket)	1	Refer to "REMOVAL POINTS".
	7	Upper bracket	1	
	8	Locknut	1	
	9	Adjuster	1	
	10	Spring guide	1	
	11	Spring (rear shock absorber)	1	

HANDLING NOTE

⚠ WARNING

This shock absorber is provided with a separate type tank filled with high-pressure nitrogen gas. To prevent the danger of explosion, read and understand the following information before handling the shock absorber.

The manufacturer can not be held responsible for property damage or personal injury that may result from improper handling.

1. Never tamper or attempt to disassemble the cylinder or the tank.
2. Never throw the shock absorber into an open flame or other high heat. The shock absorber may explode as a result of nitrogen gas expansion and/or damage to the hose.
3. Be careful not to damage any part of the gas tank. A damaged gas tank will impair the damping performance or cause a malfunction.
4. Take care not to scratch the contact surface of the piston rod with the cylinder; or oil could leak out.
5. Never attempt to remove the plug at the bottom of the nitrogen gas tank. It is very dangerous to remove the plug.
6. When scrapping the shock absorber, follow the instructions on disposal.

5

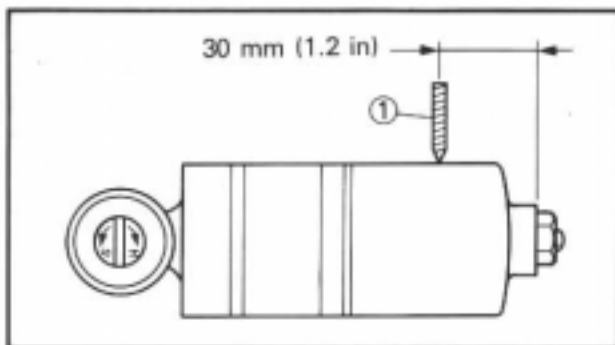
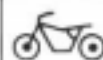

NOTES ON DISPOSAL (YAMAHA DEALERS ONLY)

Before disposing the shock absorber, be sure to extract the nitrogen gas. To do so, drill a 2 or 3 mm (0.08 ~ 0.12 in) hole through the tank at a position 30 mm (1.2 in) from the bottom end of the tank. At this time, wear eye protection to prevent eye damage from escaping gas and/or metal chips.

⚠ WARNING

To dispose of a damaged or worn-out shock absorber, take the unit to your Yamaha dealer for this disposal procedure.

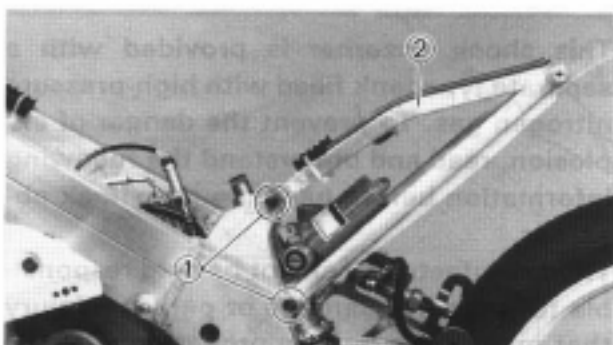

REMOVAL POINTS

Rear shock absorber

1. Remove:
 - Bolt (rear frame) ①
 - Rear frame ②

2. Remove:
 - Bolt (rear shock absorber—relay arm) ①

3. Remove:
 - Cap ①
 - Bolt (upper bracket) ②

5

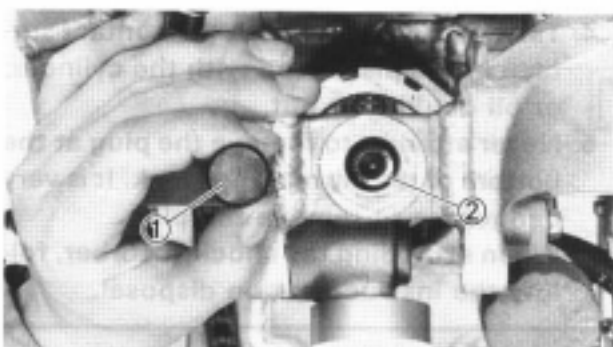
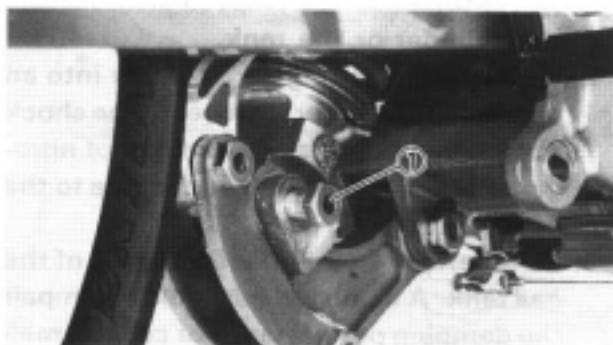

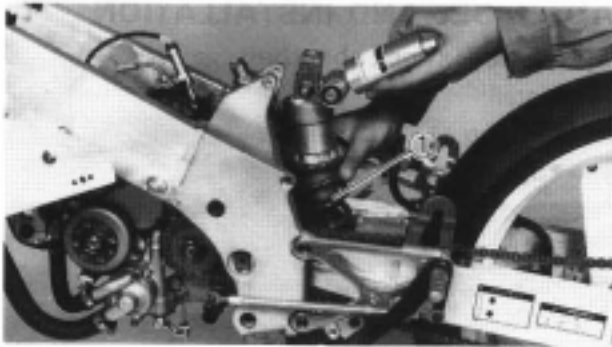

4. Remove:
- Rear shock absorber ①
From upper side.

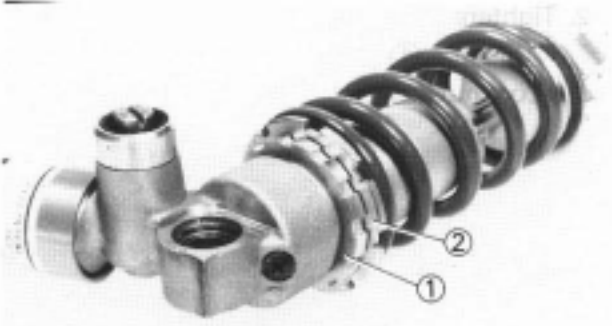

Spring (rear shock absorber)

1. Loosen:
- Locknut ①
 - Adjuster ②



2. Remove:
- Spring guide ①
 - Spring ②

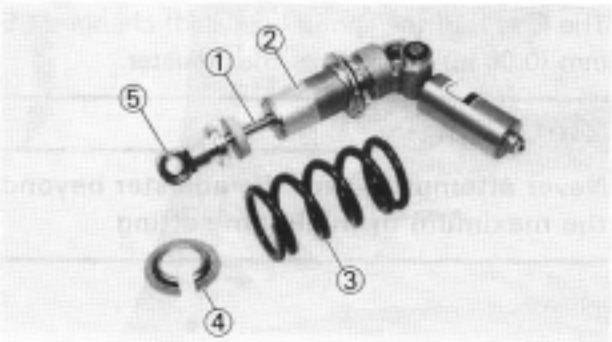

INSPECTION

Rear shock absorber

1. Inspect:
- Damper rod ①
Bends/Damage→Replace absorber assembly.
 - Shock absorber ②
Oil leaks→Replace absorber assembly.
Gas leaks→Replace absorber assembly.
 - Spring ③
Damage→Replace spring.
Fatigue→Replace spring.
Move spring up and down.
 - Spring guide ④
Wear/Damage→Replace spring guide.
 - Bearing ⑤
Free play exists/Unsmooth revolution/
Rust→Replace.

5

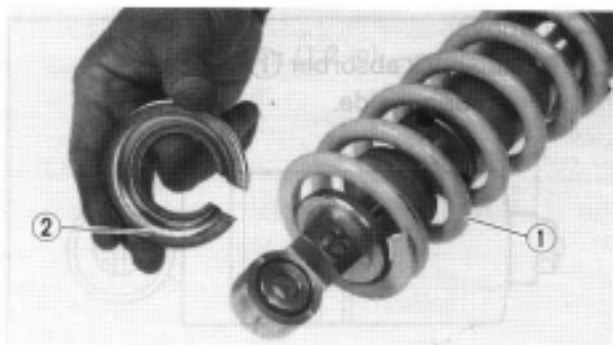

ASSEMBLY AND INSTALLATION

Spring (rear shock absorber)

1. Install:
 - Spring ①
 - Spring guide ②



2. Tighten:
 - Adjuster ①
 - Locknut ②

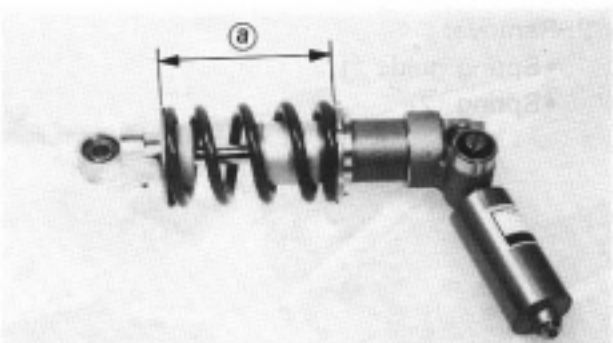

3. Adjust:
 - Spring length (a)

Spring length (installed):	
Standard length (a)	Extent of adjustment
120 mm (4.72 in)	110–123 mm (4.33–4.84 in)

NOTE: _____
 The length of the spring (installed) changes 1.5 mm (0.06 in) per turn of the adjuster.

CAUTION: _____
 Never attempt to turn the adjuster beyond the maximum or minimum setting.

5

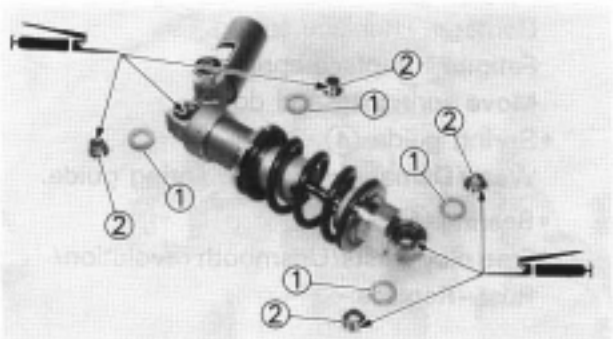

Rear shock absorber

1. Install:
 - Dush seal ①
 - Collar ②

NOTE: _____
 Apply the lithium soap base grease on the bearing.

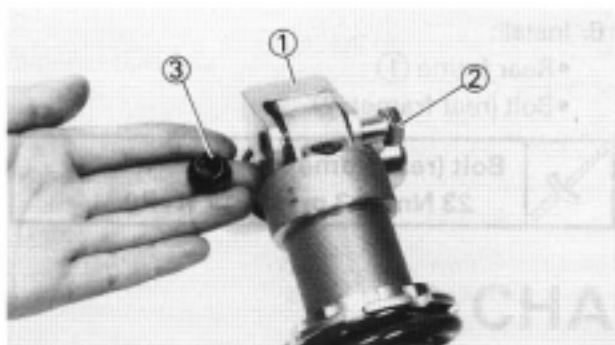

2. Install:
 - Upper bracket ①
 - Bolt (rear shock absorber—upper bracket) ②
 - Nut (rear shock absorber—upper bracket) ③

NOTE: _____

Apply the lithium soap base grease on the bolt.



Nut (rear shock absorber—upper bracket):

34 Nm (3.4 m • kg, 24 ft • lb)

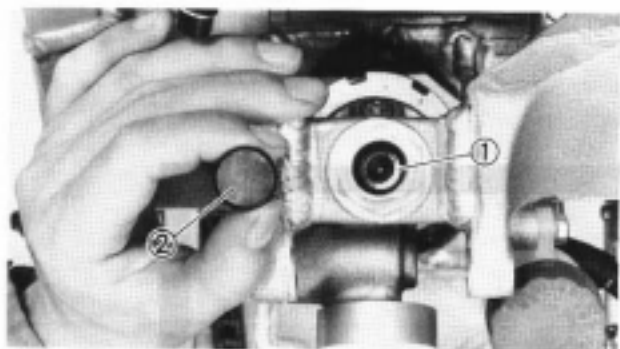

3. Install:
 - Rear shock absorber
4. Install:
 - Bolt (upper bracket) ①
 - Cap ②



Bolt (upper bracket):

30 Nm (3.0 m • kg, 22 ft • lb)

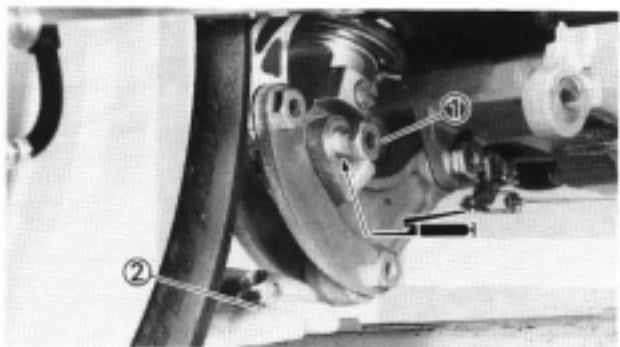

5. Install:
 - Bolt (rear shock absorber—relay arm) ①
 - Nut (rear shock absorber—relay arm) ②

NOTE: _____

Apply the lithium soap base grease on the bolt.



Nut (rear shock absorber—relay arm):

34 Nm (3.4 m • kg, 24 ft • lb)

5

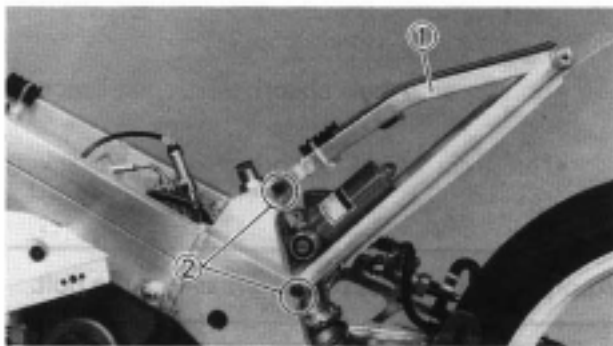

6. Install:

- Rear frame ①
- Bolt (rear frame) ②



Bolt (rear frame):

23 Nm (2.3 m•kg, 17 ft•lb)

5



ELECTRICAL COMPONENTS AND WIRING DIAGRAM

- ① CDI unit
- ② Voltage regulator
- ③ Condenser
- ④ Tachometer
- ⑤ "ENGINE STOP" button
- ⑥ Spark plug
- ⑦ Ignition coil
- ⑧ Solenoid valve
- ⑨ CDI magneto
- ⑩ Servo motor

COLOR CODE

- B Black
- Br Brown
- Gy Gray
- L Blue
- O Orange
- P Pink
- R Red
- Y Yellow
- W White

- B/Br Black/Brown
- B/R Black/Red
- B/W Black/White
- W/B White/Black
- W/G White/Green
- W/L White/Blue
- W/R White/Red
- Y/L Yellow/Blue

ELECTRICAL COMPONENTS

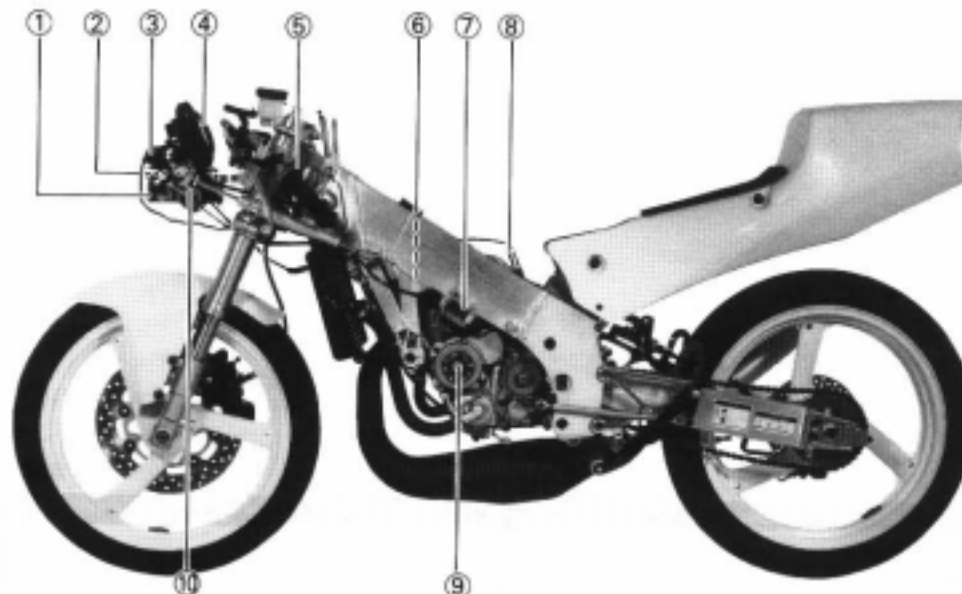

WIRING DIAGRAM

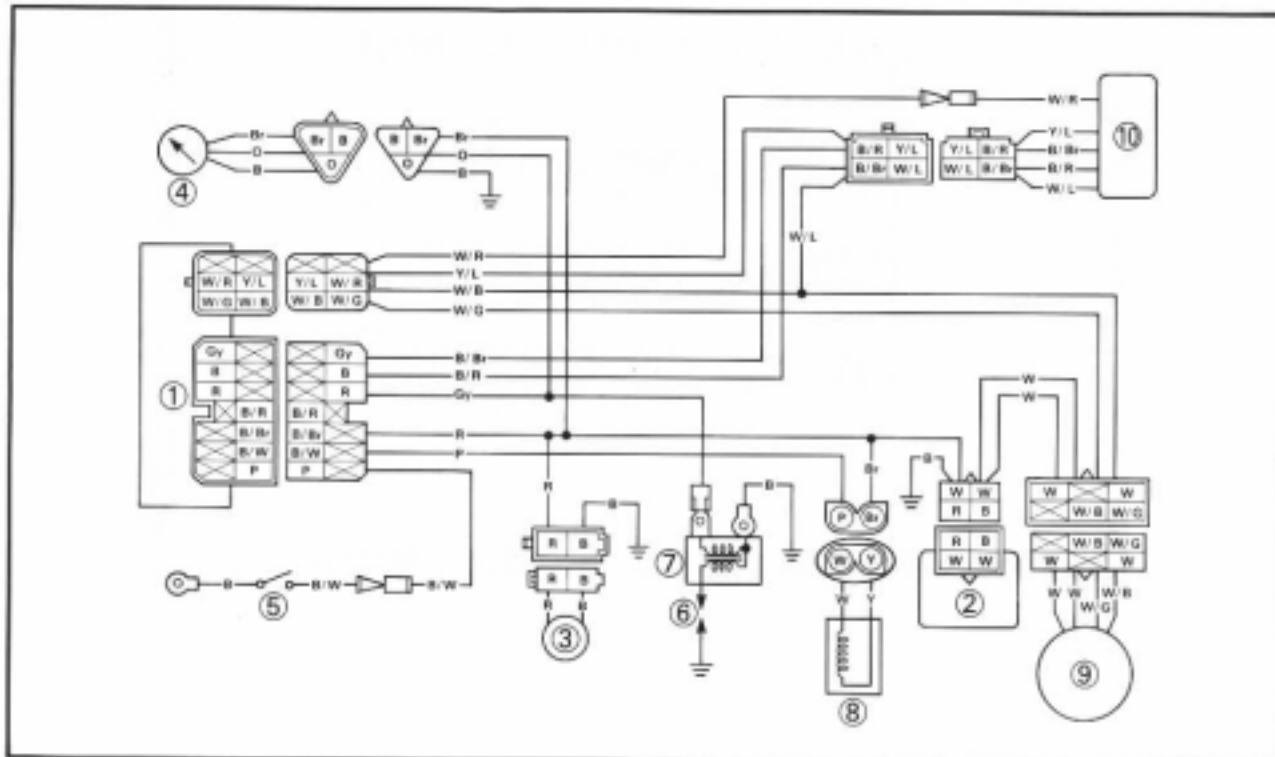

6



**IGNITION SYSTEM
INSPECTION STEPS**

Use the following steps for checking the possibility of the malfunctioning engine being attributable to ignition system failure and for checking the spark plug which will not spark.

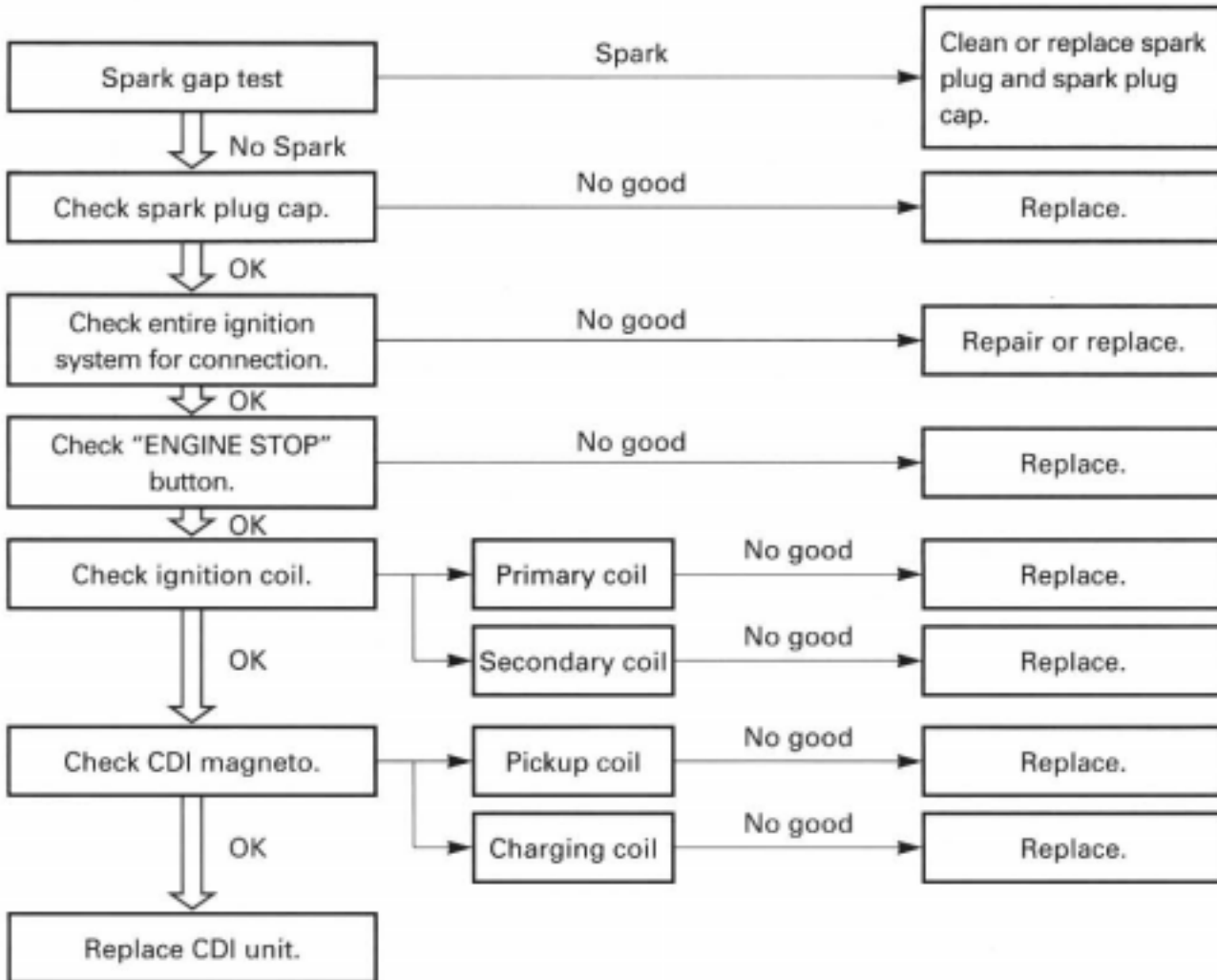

NOTE:

- Remove the following parts before inspection.
 - 1) Cowling
 - 2) Fuel tank
- Use the following special tools in this inspection.



Dynamic spark tester:
YM-34487
Ignition checker:
90890-06754



Pocket tester:
YU-03112/90890-03112

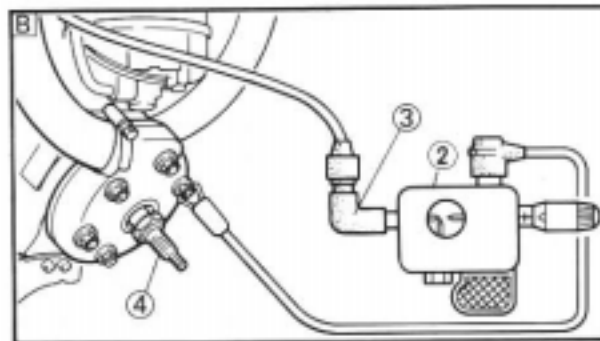
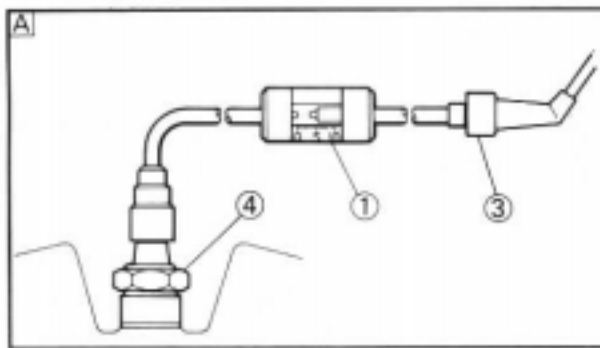

SPARK GAP TEST

1. Disconnect the spark plug cap from spark plug.
2. Connect the dynamic spark tester (1) (ignition checker (2)) as shown.
 - Spark plug cap (3)
 - Spark plug (4)

A For USA and CDN
B Except for USA and CDN

3. Start the engine and increase the spark gap until misfire occurs. (for USA and CDN)
4. Rotate the rear wheel with gear in 3rd and check the spark gap. (except for USA and CDN)

Minimum spark gap:
 5.0 mm (0.20 in)

SPARK PLUG CAP INSPECTION

1. Remove:
 - Spark plug cap

CAUTION: _____

Do not pull the spark plug lead out of the spark plug cap. Turn the spark plug cap counterclockwise to remove it and clockwise to install it.

2. Check:
 - Spark plug cap resistance
 - Out of specification → Replace.

Spark plug cap resistance	Tester selector position
4~6kΩ at 20°C (68°F)	kΩ×1

6

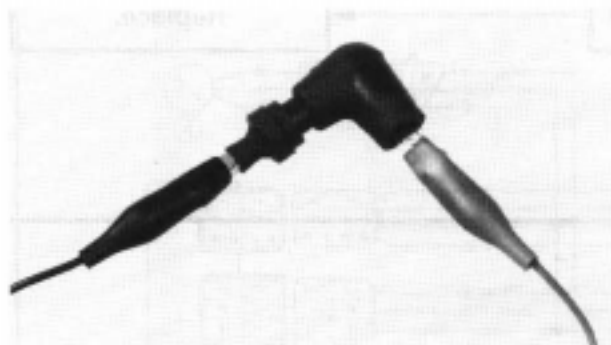

COUPLERS AND LEADS CONNECTION INSPECTION

1. Check:
 - Couplers and leads connection
 - Rust/Dust/Looseness/Short-circuit → Repair or replace.

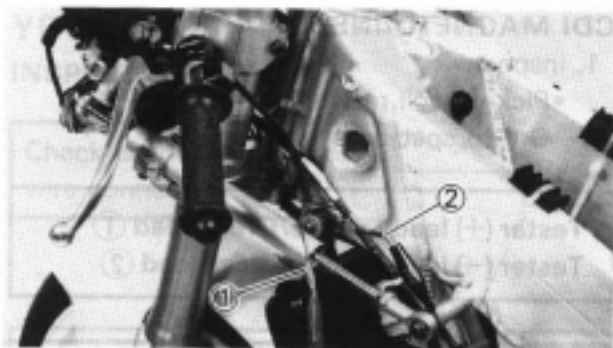

“ENGINE STOP” BUTTON INSPECTION

- Inspect:
 - “ENGINE STOP” button conduct

Tester (+) lead → Black/White lead ①
 Tester (-) lead → Black lead ②

		B/W ①	B ②	Tester selector position
	PUSH IN	○	○	Ω × 1
	FREE			

No continuity while being pushed → Replace.
 Continuity while being freed → Replace.

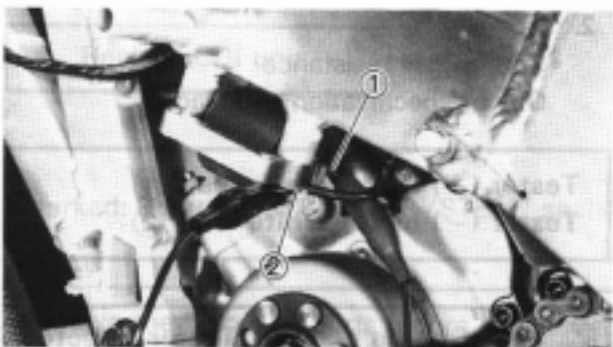

IGNITION COIL INSPECTION

- Inspect:
 - Primary coil resistance
 - Out of specification → Replace.

Tester (+) lead → Gray lead ①
 Tester (-) lead → Black lead ②

	Primary coil resistance	Tester selector position
	0.14 ~ 0.18Ω at 20°C (68°F)	Ω × 1

6

- Inspect:
 - Secondary coil resistance
 - Out of specification → Replace.

Tester (+) lead → Spark plug lead ①
 Tester (-) lead → Black lead ②

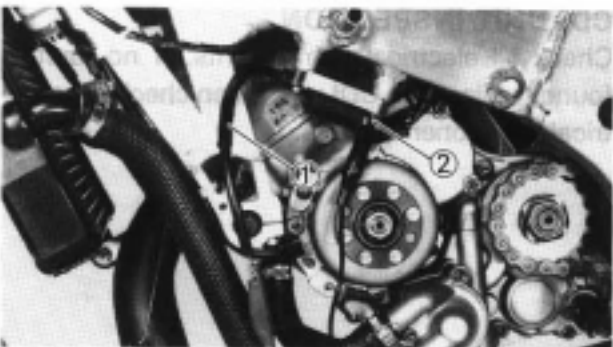

	Secondary coil resistance	Tester selector position
	5.0 ~ 7.4kΩ at 20°C (68°F)	kΩ × 1

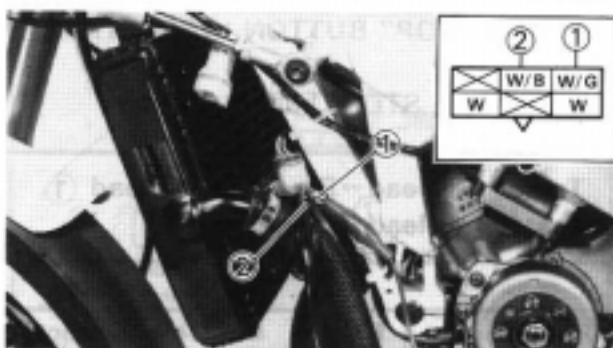

CDI MAGNETO INSPECTION

1. Inspect:

- Pick-up coil resistance
Out of specification → Replace.

Tester (+) lead → White/Green lead ①
 Tester (-) lead → White/Black lead ②

	Pick-up coil resistance	Tester selector position
	94 – 140Ω at 20°C (68°F)	Ω × 100

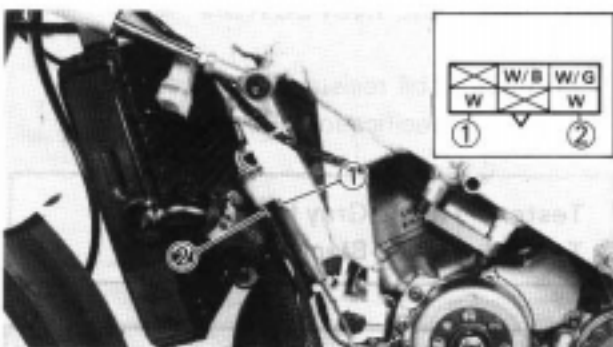

2. Inspect:

- Source coil resistance
Out of specification → Replace.

Tester (+) lead → White lead ①
 Tester (-) lead → White lead ②

	Source coil resistance	Tester selector position
	1.3 – 1.9Ω at 20°C (68°F)	Ω × 1

6

CDI UNIT INSPECTION

Check all electrical components. If no fault is found, replace the CDI unit. Then check the electrical components again.



**YPVS SYSTEM
INSPECTION STEPS**

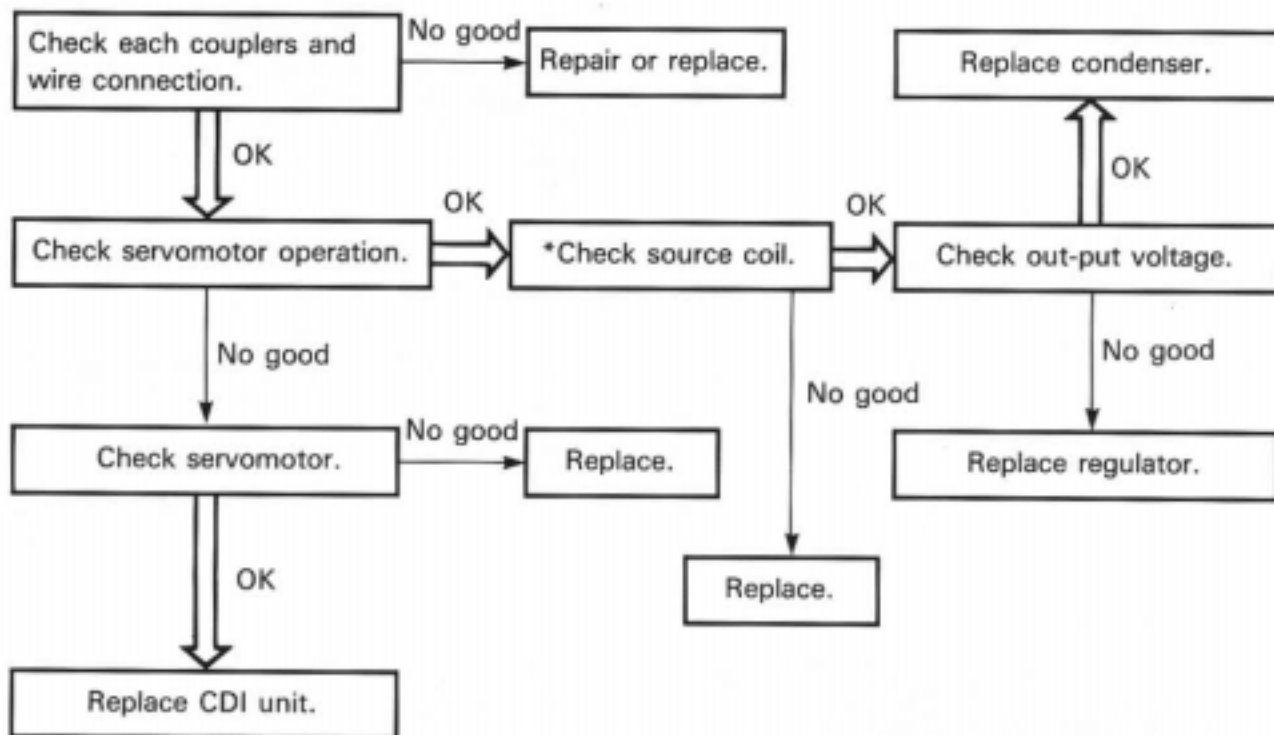

*marked: Refer to "IGNITION SYSTEM" section.

NOTE:

•Remove the following parts before inspection.

- 1) Cowling
- 2) Fuel tank

•Use 12V battery in this inspection.



COUPLERS AND LEADS CONNECTION INSPECTION

1. Check:
 - Couplers and leads connection
 - Rust/Dust/Looseness/Short-circuit → Repair or replace.

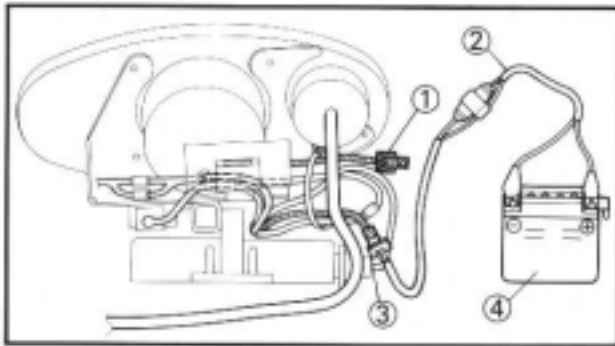

SERVOMOTOR OPERATION

1. Disconnect the condenser lead ①.
2. Connect the checking lead (with supplying parts) ② between the wire harness ③ and battery (12V) ④.

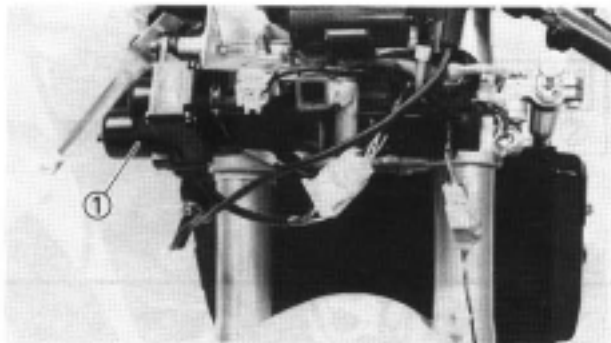

3. Inspect:
 - Servomotor ①
 - Operate → If no failure is found in checking the source coil resistance and voltage regulator out-put voltage, replace the condenser.

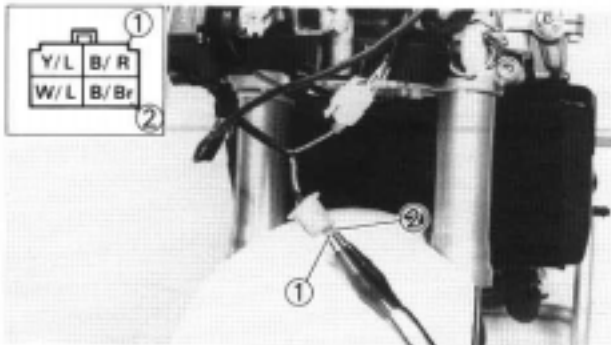

SERVOMOTOR INSPECTION

1. Disconnect the YPVS cable from the servomotor.
2. Disconnect the servomotor coupler.
3. Connect 12V battery to the servomotor coupler.

Battery (+) lead → Black/Red lead ①
 Battery (-) lead → Black/Brown lead ②

4. Inspect:
 - Servomotor ①
 - Not operate → Replace the servomotor.

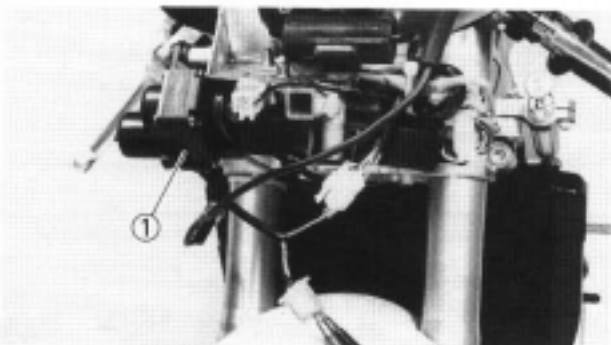

6

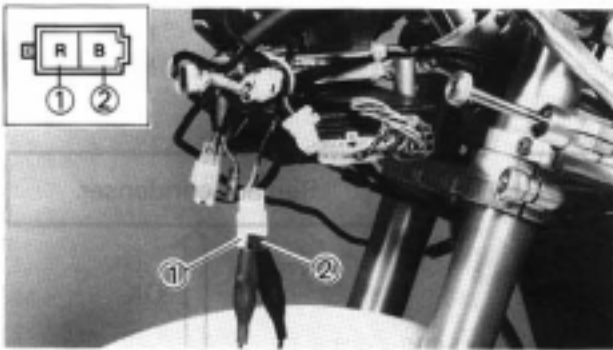

OUT-PUT VOLTAGE INSPECTION

1. Disconnect the condenser coupler.
2. Start the engine.
3. Inspect:
 - Out-put voltage
Out of specification→Replace the volt-
age regulator.

Tester (+) lead→Red lead ①
 Tester (-) lead→Black lead ②

	Out-put voltage	Tester selector position
	14~15V at 5,000 r/min	DCV-20



SOLENOID VALVE SYSTEM INSPECTION STEPS

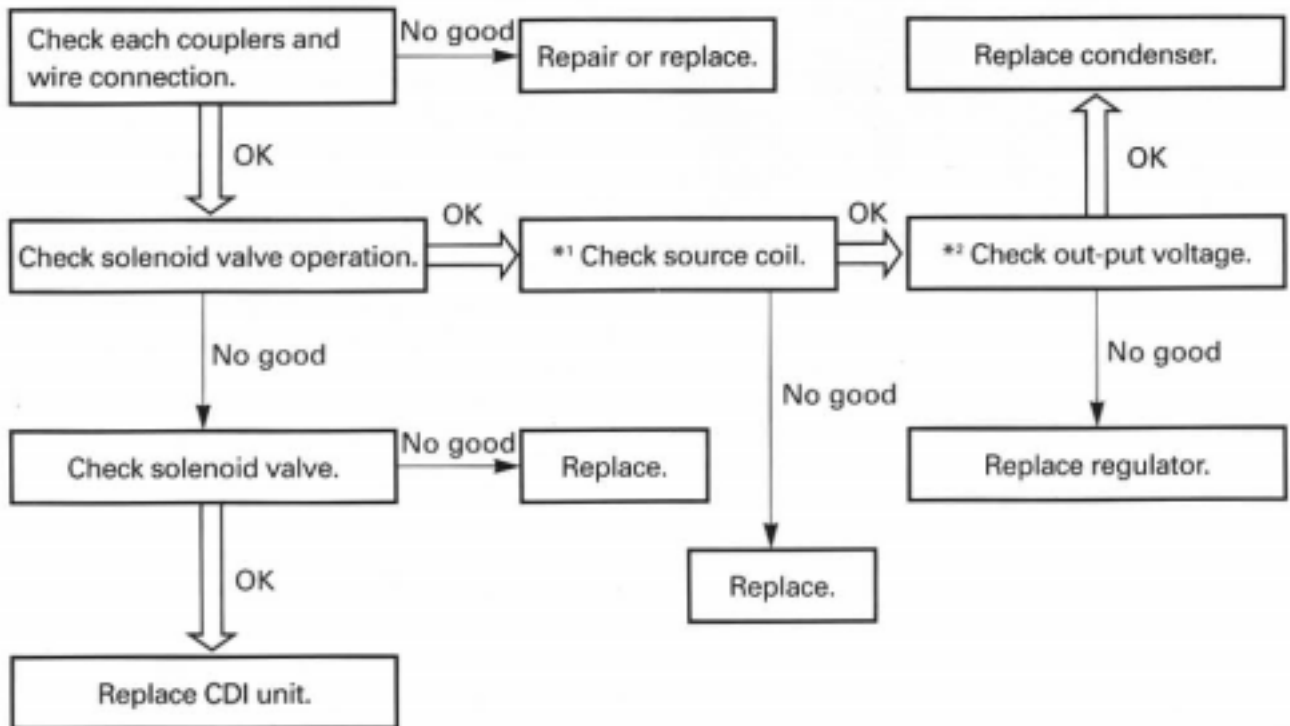

*1 marked: Refer to "IGNITION SYSTEM" section.

*2 marked: Refer to "YPVS SYSTEM" section.

NOTE:

•Remove the following parts before inspection.

- 1) Cowling
- 2) Fuel tank

•Use 12V battery in this inspection.

COUPLERS AND LEADS CONNECTION INSPECTION

- Check:
 - Couplers and leads connection
Rust/Dust/Looseness/Short-circuit → Repair or replace.

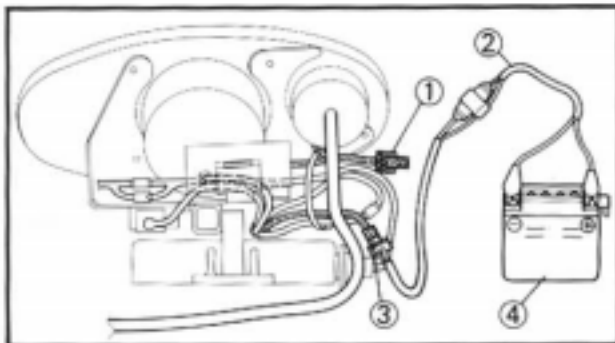

SOLENOID VALVE OPERATION

- Check:
 - Solenoid valve operation

Checking steps:

- Disconnect the condenser lead ①.
- Connect the checking lead (with supplying parts) ② between the wire harness ③ and battery (12V) ④.
- Check the solenoid valve ⑤ operation. If a click can be heard the solenoid valve is working properly.
No click → Check the coupler and lead connection
- Check the solenoid valve resistance.

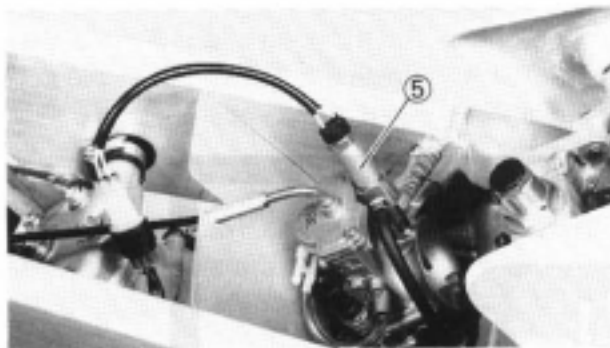

SOLENOID VALVE INSPECTION

- Inspect:
 - Solenoid resistance
Out of specification → Replace.

Tester (+) lead → Yellow lead ①
Tester (-) lead → White lead ②



	Solenoid resistance	Tester selector position
	52.0 ~ 63.6Ω at 20°C (68°F)	Ω × 10

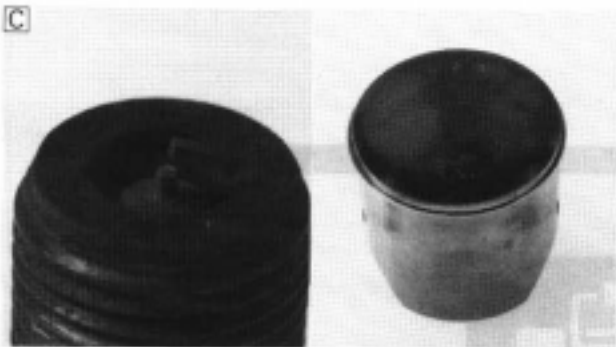

Carburetor setting

- The role of fuel is not only to produce motive power but also to cool the engine and, in the case of a 2-stroke engine, to lubricate it. Therefore, too lean a mixture (of air and fuel) tends to cause an abnormal combustion (i.e., detonation), whereas too rich a mixture makes it difficult for the engine to develop its full performance, with the result that in some cases the spark plug may be fouled, causing the engine to stop running.

- The richness of a fuel mixture varies with different weather conditions and thus the carburetor must be properly set to suit the atmospheric conditions (air pressure, humidity and temperature) of the day.

- As a basic setting method, only the factory set main jet is first changed to check for the discoloration of the spark plug(s) and piston(s) at full throttle in 6th and then the setting is determined at mid-open throttle.

- Recording and storing the data on the settings, weather conditions, road surface conditions of the circuit, lap times, etc. will enable quick setting under different conditions at a later time.

- A** Normal
- B** Over burned (too lean)
- C** Oil fouled (too rich)



Atmospheric conditions and carburetor setting

Air temp.	Humidity	Air pressure (altitude)	Mixture	Setting
High	High	Low (high)	Richer	Leaner
Low	Low	High (low)	Leaner	Richer

The reason for the above tendency is that the richness or leanness of a fuel mixture depends on the density of the air (i.e. the concentration of oxygen in it).

That is:

- Higher temperature expands the air with its resultant reduced density.
- Higher humidity reduces the amount of oxygen in the air by so much of the water vapor in the same air.
- Lower atmospheric pressure (at a high altitude) reduces the density of the air.

Effects of setting parts in relation to throttle valve opening

Setting parts	Throttle valve opening					
	0	1/8	1/4	1/2	3/4	7/8
Pilot air screw						
Pilot jet						
Main nozzle Jet needle						
Main Jet						
Power Jet						

NOTE: _____

The power jet closes at 12,150 rpm of the engine, after which only the main jet dominates.

7

**Basic process of carburetor setting**

Ex-factory setting is on the richer side, which should basically have no problems with the brake-in procedure.

(Refer to "STARTING AND BREAK-IN" in the CHAPTER 1.)

1. Adjustment of main jet

Use a main jet with a smaller calibration number if the engine does not develop more than 12,000 rpm after a few laps of the circuit when the water temperature becomes stable [55°C (131°F) or more].

Example: #560 → #540

Next run a few laps of the circuit with this setting and check for any difference in engine revolutions. If no difference is noticed, use a main jet with a much smaller calibration number.

Example: #540 → #520

2. Checking of spark plug and piston for discoloration.

Repeat the adjustment in the above "1" several times. If the engine begins to run at more than 12,000 rpm at full throttle, proceed to the "spark plug chopping" step (refer to P7-8) to check for the discoloration of the spark plug(s) and piston(s). Refer to the photo on P7-1 for judgement on the discoloration.

As a novice will find it difficult to determine how much smaller number main jet can be used just by looking at discoloration, he should consult an experienced person for his own experience, too.

Whether the setting is proper or not can be judged by engine revolutions.

Approximate criteria for such judgement are given below, on condition that the secondary reduction ratio is fit for conditions of the circuit.

- 13,000 rpm in 1st and 2nd
- 12,500 rpm in 5th and 6th



3. Adjustment of main nozzle

The main nozzle adjustment follows the completion of the adjustment of the main jet. Check that engine revolutions smoothly respond to throttle opening from where throttle is about to be opened to 1/2 throttle opening. Use a main nozzle of a smaller size if engine revolutions appear to falter at the beginning of throttle opening and then suddenly respond to further throttle opening.

Example: R7 → R5

If the main jet is fully adjusted with not much allowance for discoloration, use a main jet which is approximately #20 larger.

Run a few laps of the circuit to check the engine for response to revolutions. Also check for the discoloration of the spark plug(s) and piston(s).

Use a main jet of a smaller size if good response to engine revolutions is achieved with an allowance for the discoloration of the spark plug(s) and piston(s).

On the other hand, if the use of a different main nozzle appears to produce less power, change to a main nozzle of a larger size.

Example: R5 → R6

NOTE: _____

Difference between individual riders or difference between circuit layouts greatly affect the main nozzle setting.

- Rider who frequently uses mid-open throttle
- Circuit that requires frequent throttle opening and closing
- Wet environment

Conditions as mentioned above require a longer period of throttle closing, resulting in the drawn in mixture staying longer in the crankcase. Such setting in turn will inevitably cause the mixture to be richer at the next throttle opening, a main jet of a smaller size has to be used.



Carburetor settings by correction coefficient

Now you should be able to understand the essentials of basic carburetor setting from an explanation given under "Basic process of carburetor setting" (P7-3).

Next is an explanation of how to select a main jet to deal with changes in weather conditions by means of a correction coefficient.

NOTE: _____

- Before this correction coefficient can be used, satisfactory carburetor setting must have been made.
- This correction coefficient can not be used if there is a change in specification (e.g., ignition timing, compression ratio, etc.).

Illustration:

Suppose the best setting was represented by a #450 main jet at an air pressure of 760 mm Hg and an air temperature of 20°C (68°F) in the previous riding.

In this riding, there has been a substantial change in conditions; namely, an air pressure of 755 mmHg and an air temperature of 30°C (86°F).

1. Refer to a table of correction coefficients (P7-6) to find the correction coefficient for the previous riding.

The correction coefficient A=100.0

2. Find the correction coefficient for this time.

The correction coefficient B=96.1

3. Use the following equation to calculate the size of a main jet needed in this particular case.

$\text{Previous main jet size} \times B/A$ $= \text{Currently required main jet size}$
--

$$450 \times 96.1/100=432.5$$



Thus, a #430 main jet can be selected.

CAUTION:

If a change in conditions require a main jet of a larger size, use the size to which #20 is added for safety.

NOTE:

- Since this correction coefficient table lacks a column for humidity, it is advisable to check the degree of discoloration of the spark plug(s) for final selection according to an explanation under "Atmospheric conditions and carburetor setting" (P7-2).
- As the main nozzle is more susceptible to other than atmospheric conditions, no correction coefficient is used for main nozzle setting.

Table of correction coefficients for carburetor setting

Air pressure mmHg	Air temperature °C (°F)										Altitude m (ft)
	-5 (23)	Zero (32)	5 (41)	10 (50)	15 (59)	20 (68)	25 (77)	30 (86)	35 (95)	40 (104)	
780	112.2	110.2	108.2	106.3	104.4	102.6	100.9	99.3	97.7	96.1	-220 (-722)
775	111.5	109.4	107.5	105.6	103.7	102.0	100.3	98.6	97.0	95.5	-165 (-541)
770	110.8	108.7	106.8	104.9	103.1	101.3	99.6	98.0	96.4	94.8	-110 (-361)
765	110.0	108.0	106.1	104.2	102.4	100.7	99.0	97.3	95.8	94.2	-55 (-180)
760	109.3	107.3	105.4	103.5	101.7	100.0	98.3	96.7	95.1	93.6	Zero (Zero)
755	108.6	106.6	104.7	102.9	101.1	99.3	97.7	96.1	94.5	93.0	56 (184)
750	107.9	105.9	104.0	102.2	100.4	98.7	97.0	95.4	93.9	92.4	112 (367)
745	107.2	105.2	103.3	101.5	99.7	98.0	96.4	94.8	93.3	91.8	168 (551)
740	106.5	104.5	102.6	100.8	99.1	97.4	95.7	94.2	92.6	91.1	224 (735)
735	105.7	103.8	101.9	100.1	98.4	96.7	95.1	93.5	92.0	90.5	281 (922)
730	105.0	103.1	101.2	99.4	97.7	96.1	94.4	92.9	91.4	89.9	338 (1,109)
725	104.3	102.4	100.5	98.8	97.1	95.4	93.8	92.2	90.7	89.3	396 (1,299)
720	103.6	101.7	99.8	98.1	96.4	94.7	93.1	91.6	90.1	88.7	453 (1,486)
715	102.9	101.0	99.2	97.4	95.7	94.1	92.5	91.0	89.5	88.1	512 (1,680)
710	102.1	100.3	98.5	96.7	95.0	93.4	91.9	90.3	88.9	87.5	570 (1,870)
705	101.4	99.6	97.8	96.0	94.4	92.8	91.2	89.7	88.2	86.8	629 (2,054)
700	100.7	98.9	97.1	95.4	93.7	92.1	90.6	89.1	87.6	86.2	688 (2,257)
695	100.0	98.1	96.4	94.7	93.0	91.4	89.9	88.4	87.0	85.6	747 (2,451)
690	99.3	97.4	95.7	94.0	92.4	90.8	89.3	87.8	86.4	85.0	807 (2,648)
685	98.5	96.7	95.0	93.3	91.7	90.1	88.6	87.2	85.7	84.4	867 (2,845)
680	97.8	96.0	94.3	92.6	91.0	89.5	88.0	86.5	85.1	83.8	928 (3,045)
675	97.1	95.3	93.6	92.0	90.4	88.8	87.3	85.9	84.5	83.1	989 (3,245)
670	96.4	94.6	92.9	91.3	89.7	88.2	86.7	85.2	83.9	82.5	1,050 (3,445)
665	95.7	93.9	92.2	90.6	89.0	87.5	86.0	84.6	83.2	81.9	1,111 (3,645)
660	94.9	93.2	91.5	89.9	88.3	86.8	85.4	84.0	82.6	81.3	1,173 (3,848)
655	94.2	92.5	90.8	89.2	87.7	86.2	84.7	83.2	82.0	80.7	1,236 (4,056)
650	93.5	91.8	90.1	88.5	87.0	85.5	84.1	82.7	81.4	80.1	1,299 (4,262)
645	92.8	91.1	89.4	87.9	86.3	84.9	83.4	82.1	80.7	79.4	1,362 (4,469)
640	92.1	90.4	88.8	87.2	85.7	84.2	82.8	81.4	80.1	78.8	1,425 (4,675)
635	91.3	89.7	88.1	86.5	85.0	83.6	82.2	80.8	79.5	78.2	1,489 (4,885)
630	90.6	89.0	87.4	85.8	84.3	82.9	81.5	80.2	78.9	77.6	1,554 (5,099)

7



Other setting parts

1. Jet needle

As a rule, the clip position is not changed. The mid-open setting basically depends on the main nozzle.

Standard clip position	No. 3 groove
-------------------------------	---------------------

2. Power jet

Power jet is not basically changed. Since the areas of the main jet and main nozzle overlap each other, special knowledge is required for a setting change.

A larger size results in a richer mixture and a smaller size in a leaner mixture.

Standard power jet	#60
---------------------------	------------

3. Pilot jet

The pilot jet is used in relation to the engine response at small throttle opening. This is changed when the main nozzle setting is not enough.

A larger size results in a richer mixture and a smaller size in a leaner mixture.

Standard pilot jet	#20
---------------------------	------------

4. Pilot air screw

The pilot air screw relates to the engine response at a smaller opening than for the pilot jet.

This setting may be changed for want of time or in emergency, but it is basically set at the standard pilot air screw position.

Standard pilot air screw position	1-1/2 turn out
--	-----------------------



5. Spark plug

The spark plug heat range is not basically changed.

Constant attention to the discoloration of the spark plug and piston head will enable you to tell to some extent whether the setting is good or bad.

Standard spark plug	R6385-105P/NGK
---------------------	----------------

NOTE:

For the effects each setting part has, refer to "Effects of setting parts in relation to throttle valve opening" (P7-2).

Plug chop

When checking the discoloration of the spark plug and piston head, push the "ENGINE STOP" button while running along a straight lane at full throttle, disengage the clutch at the same time and stop the engine. Then let your machine go back to the pit by inertia. This is called a "plug chop".

CAUTION:

- When you do a "plug chop", pay attention to your surrounding environment to avoid interference with other riders.
- Do not shift down while riding your machine by inertia (as it may cause a seizure of the clutch push rod and ball).

Setting of cylinder gasket

The use of the supplied gaskets of different thicknesses makes it possible to change the combustion chamber volume to deal with changing weather conditions.

Not much torque is felt with slow engine acceleration → Reduce the combustion chamber volume.

Torque is felt with no higher revolutions → Expand the combustion chamber volume.

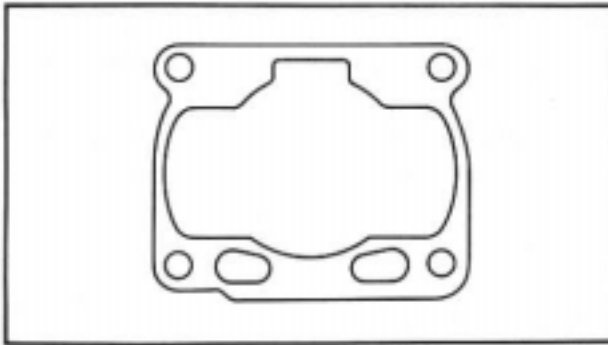

Thickness	Actual combustion chamber volume	Type
0.8 mm (0.031 in)	Approx. 8.20 cm ³ (0.289 Imp oz, 0.277 US oz)	STD
0.7 mm (0.028 in)	Approx. 7.95 cm ³ (0.280 Imp oz, 0.269 US oz)	Supplying parts
0.6 mm (0.024 in)	Approx. 7.70 cm ³ (0.271 Imp oz, 0.250 US oz)	

NOTE:

- Finish adjusting the carburetor setting before changing the gasket.
- A change of 0.1 mm (0.004 in) for the gasket causes a change of approximately 0.25 cm³ (0.009 Imp oz, 0.008 US oz) of the combustion chamber volume.

When the cylinder gasket is changed, measure the protruding (or sinking) amount of the piston above (below) the cylinder top and then change the cylinder gasket so that the following approximate relation can be achieved between the temperature and the piston protruding amount. (The table shows an example when the air pressure is 760 mmHg.)

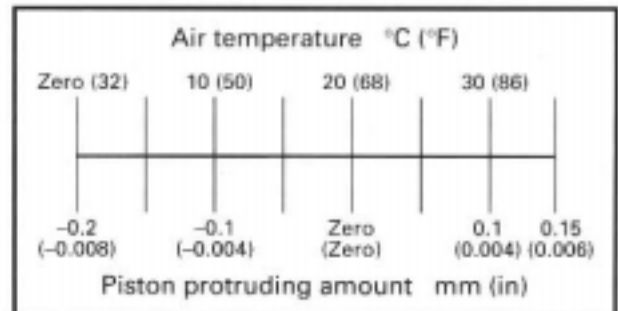
**CAUTION:**

- Piston protruding amount must be a maximum 0.15 mm (0.006 in). Above this value, the piston and cylinder head may contact each other.
- As the air pressure becomes lower at a higher altitude, slide to the right the temperature scale readings by 10°C (50°F) each for every change in the air pressure of 20 mmHg.
- Too much random piston protrusion at low temperature may develop an abnormal combustion (detonation), which may adversely affect the intended performance of the engine.

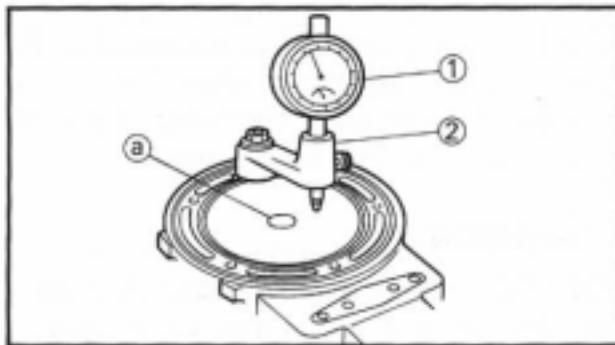
**Measuring piston protrusion**

Install the dial gauge ① and dial gauge stand ② to the cylinder and measure the piston protrusion.

**Dial gauge:**

YU-03097/90890-01252

Stand:

YU-01256

NOTE: _____

For measurement, avoid the top center projected area ① on the piston head but measure the area above the piston pin as close to the center as possible.

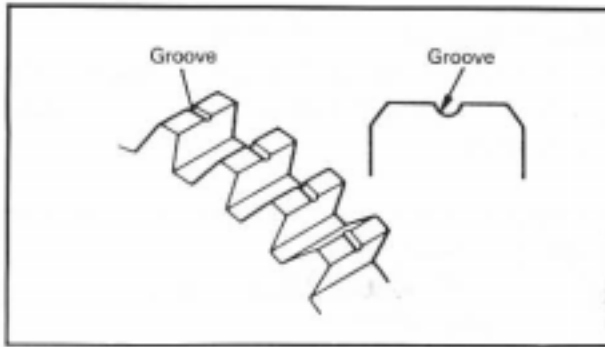

Selection of transmission gear ratio

The following gear sets are contained in the supplying (or optional) to allow the rider to change the gear ratios according to the circuit condition or rider's preference.

CAUTION:

Select the transmission gears so that the number of grooves in the wheel gear match that of the pinion gear as shown below. Trouble may be occurred if the selection is different than that listed below.

1st gear

	Gear ratio	Part number	Number of groove
Factory installed	30/15 (2.000)	4JT-17211-00/4JT-17411-00	—
Supplying part	29/15 (1.933)	4JT-17211-10/4JT-17411-00	1/-

2nd gear

	Gear ratio	Part number	Number of groove
Supplying part	35/21 (1.667)	4JT-17221-00/4JT-17121-00	—
Factory installed	27/17 (1.588)	4JT-17221-10/4JT-17121-10	1
Supplying part	30/20 (1.500)	4JT-17221-20/4JT-17121-20	2

3rd gear

	Gear ratio	Part number	Number of groove
Supplying part	23/16 (1.438)	4JT-17231-00/4JT-17131-00	—
Factory installed	26/19 (1.368)	4JT-17231-10/4JT-17131-10	1
Supplying part	25/19 (1.316)	4JT-17231-20/4JT-17131-20	2

4th gear

	Gear ratio	Part number	Number of groove
Supplying part	28/22 (1.278)	4JT-17241-00/4JT-17141-00	—
Factory installed	27/22 (1.227)	4JT-17241-10/4JT-17141-10	1
Supplying part	24/20 (1.200)	4JT-17241-20/4JT-17141-20	2

5th gear

	Gear ratio	Part number	Number of groove
Supplying part	30/26 (1.154)	4JT-17251-00/4JT-17151-00	—
Factory installed	26/23 (1.130)	4JT-17251-10/4JT-17151-10	1
Supplying part	23/21 (1.095)	4JT-17251-20/4JT-17151-20	2

6th gear

	Gear ratio	Part number	Number of groove
Supplying part	23/21 (1.095)	4JT-17261-00/4JT-17161-00	—
Factory installed	29/27 (1.074)	4JT-17261-10/4JT-17161-10	1
Supplying part	23/22 (1.045)	4JT-17261-00/4JT-17161-20	-/2



Suspension setting

How to go about setting the machine

- Measure the stroke of the front and rear suspension to get an idea of the operation.
- If the time increases, the stroke increases.
- If the tire grip becomes firmer, the stroke increases.
(On the other hand, the stroke decreases on rainy weather.)
- Rider's position and posture affect the stroke.
- Be careful not to allow the suspension to bottom out.
- Start the setting with the preload.

Next, go to the damping force adjustment, and if this is not enough, then adjust the machine height.
(On the side where the machine height is greater the stroke increases; whereas it decreases on the side with a smaller machine height.)

- If the damping force is increased either on the compression or the expansion side, it results in less smooth movement, so do not depart too far from the standard settings.
- Adjust the machine height in an increment of mm.
- If you lose your way while doing the setting, go back to the standard settings.
- Oil level adjustment in the front fork produces a greater effect in further stroke than in mid stroke.
(Increase or decrease the oil level in an approximately 5 to 10 mm (0.20 ~ 0.39 in) interval.)



Settings

For full use of engine performance and safe riding, set the suspension as follows. (Ex-factory settings are intended for a rider approximately 170 cm (6.69 in) in height and approximately 60 kg (132 lb) in weight.)

1. Preparations

To check for the remaining stroke in the front and rear suspension, either install a thin insu-lock tie or apply a small amount of grease at the front fork inner tube and at the rear shock absorber rod.

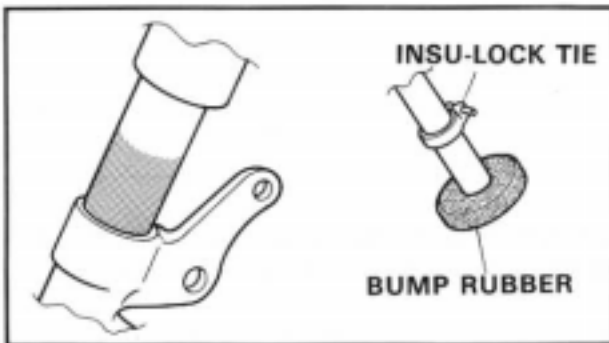

The figures below show the bottom-out positions of the front and rear suspension.

[Front]

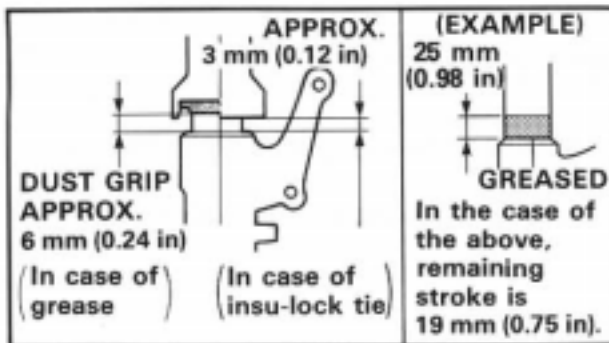

[Rear]

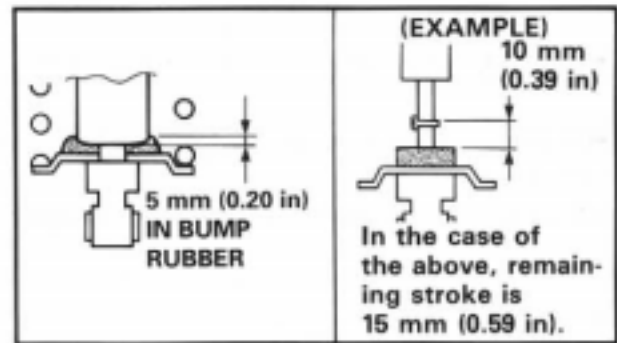

2. Settings

At the beginning of the break-in period, always record the remaining stroke as data.

To judge front and rear balance in relation to the machine height, the usual way is to shift from full braking to turning and get the feel when the clipper riding.

After making an actual run, proceed to the settings for a target of a 5 to 10 mm (0.20~0.39 in) remaining stroke for front and a 10 to 20 mm (0.39 ~ 0.79 in) remaining stroke for rear. Basically, the best settings can be obtained by repeating the following steps.

7



SETTING CHART

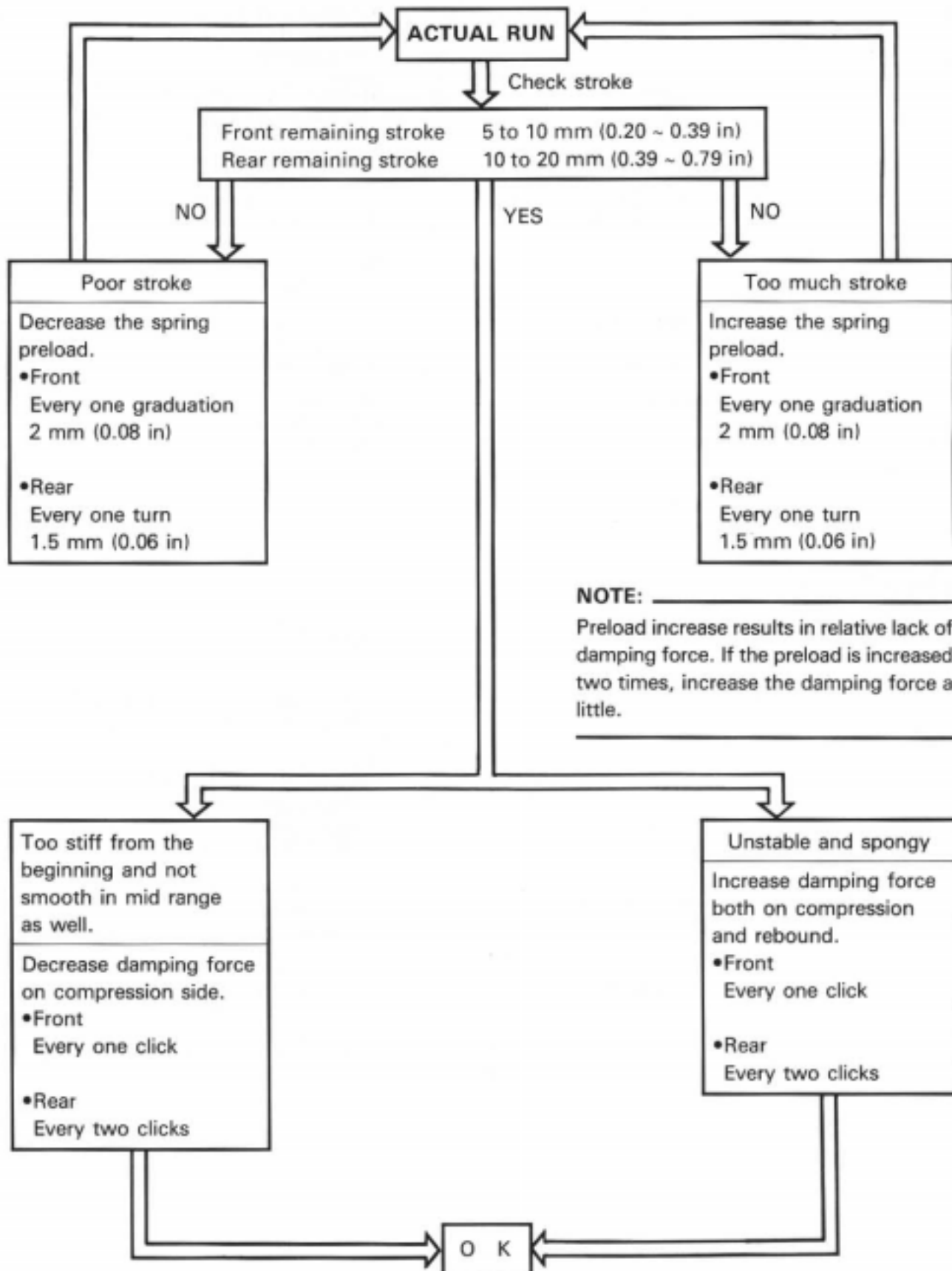



Symptom

Chattering
(Small
rebounds,
up-and-down
movements)

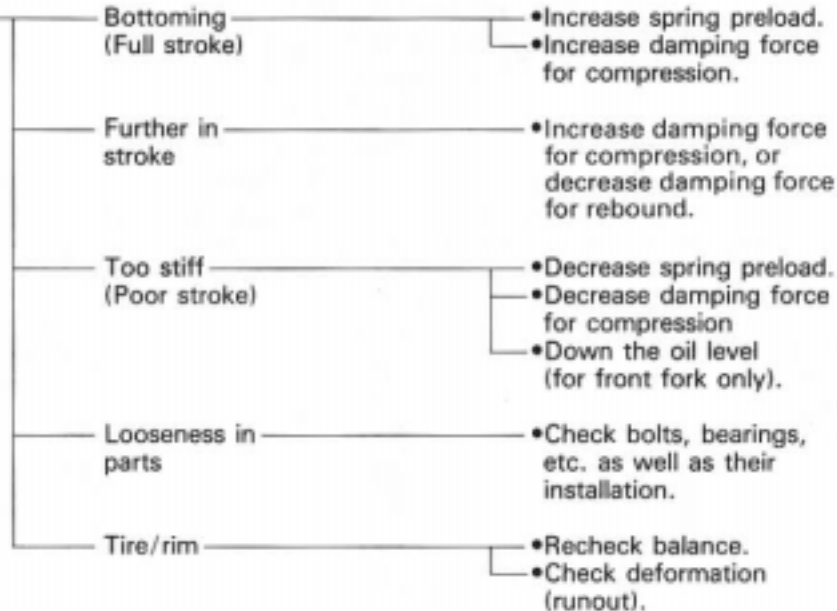

Too stiff
feeling

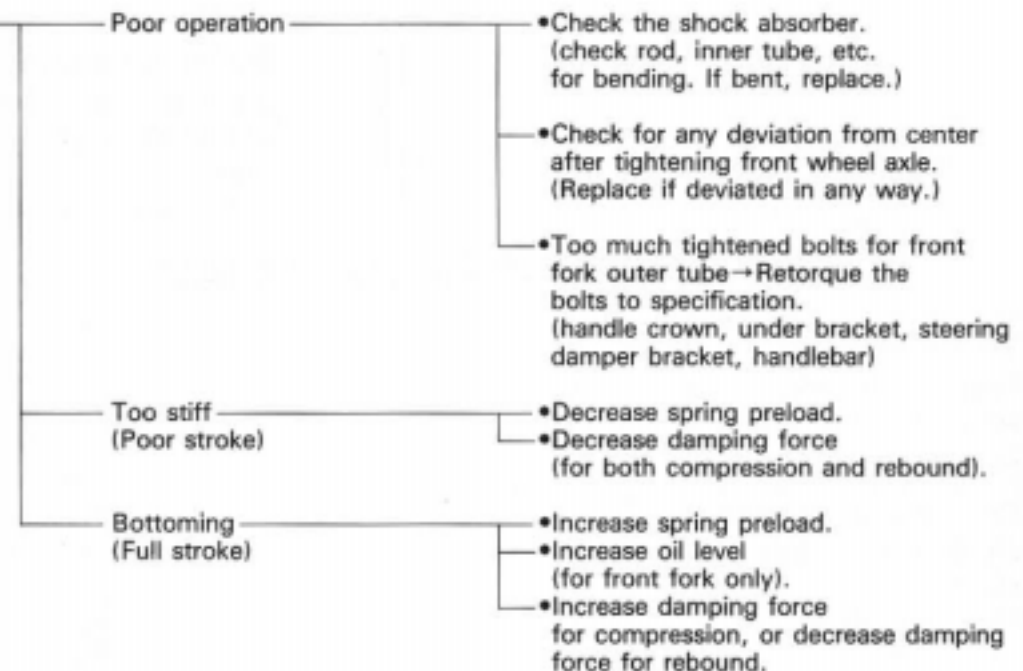

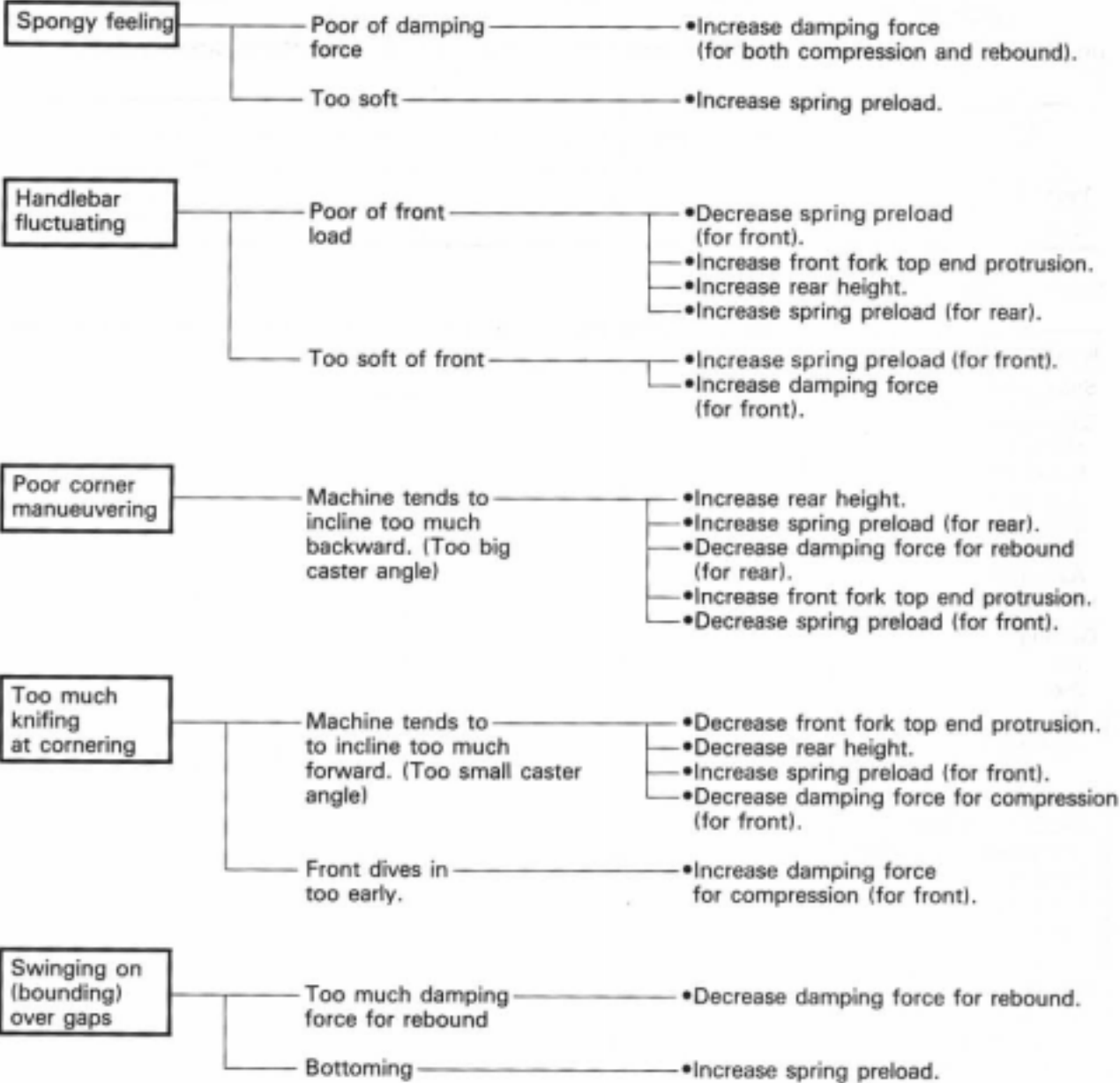



Event name				
Date				
Weather				
Place				

Setting specs.

Ignition timing				
Spark plug				
Carburetor Main jet Power jet Jet needle Main nozzle Pilot jet Air screw Float height				
Gearing 1st 2nd 3rd Secondary				
Front fork Spring pre-load Rebound damping Compression damping Tube height Oil quantity Level Weight				
Rear shock Spring fitting length Rebound damping Compression damping Seat height				
Front tire (pressure)				
Rear tire (pressure)				
Fuel consumption				

NOTE:

1. Make setting changes in small increments.
2. When the proper settings have been determined for a particular track, they should be written down for reference upon returning to that track.
3. Always make adjustment in cold state.